



DIGITAL INDUSTRIES SOFTWARE

# Simcenter 3D for multiphysics simulation

Leveraging the use of industry-standard solvers for a full range of applications

## Solution benefits

Enables users to take advantage of industry-standard solvers for a full range of applications

Makes multiphysics analysis safer, more effective and reliable

Enables product developers to comprehend the complicated behavior that affects their designs

Promotes efficiency and innovation in the product development process

Provides better products that fulfill functional requirements and provide customers with a safe and durable solution

**Complex industrial problems require solutions that span a multitude of physical phenomena, which often can only be solved using simulation techniques that cross several engineering disciplines. This has significant consequences for the computer-aided engineering (CAE) engineer. In the simplest case, the physics may be weakly coupled and it is accurate and easy to chain the different physics solutions. The response results from the first solution provides data to be used as load input by a second physics solution. Because of weak coupling, the second physics does not affect the first physics.**

**But when there is stronger coupling between physics they cannot be treated separately and a more tightly coupled solution is required. In that case, a complex algorithmic basis with advanced coupling schemes are required to run the different physics solutions simultaneously which is often referred to as cosimulation.**



Multiphysics

SIEMENS

[siemens.com/simcenter3d](https://www.siemens.com/simcenter3d)

# Simcenter 3D for multiphysics simulation

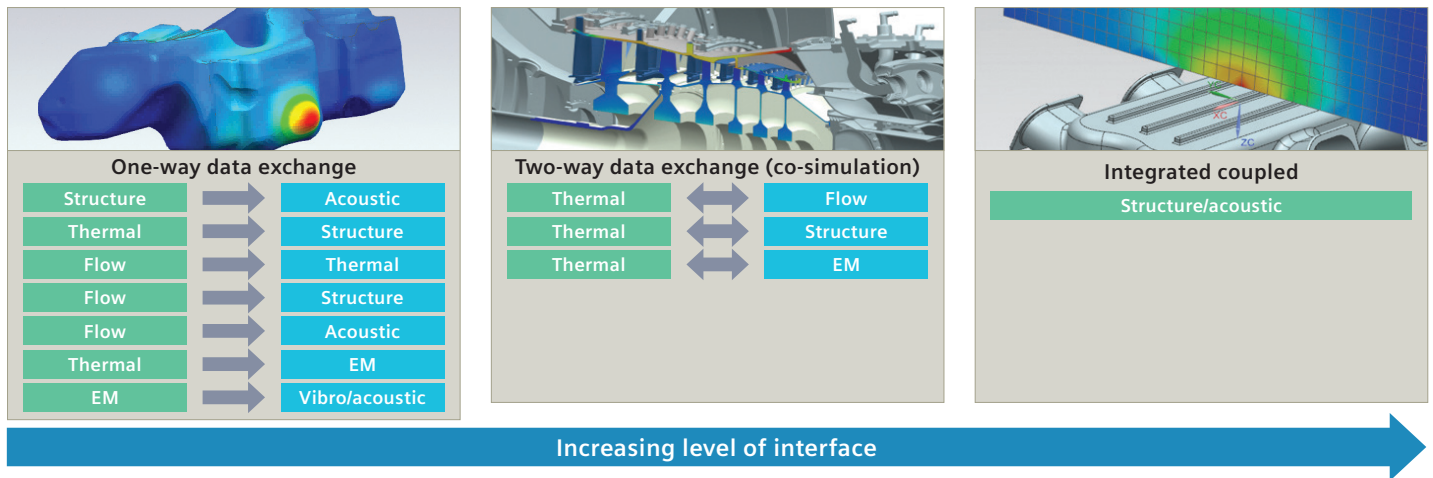

Simcenter™ 3D software streamlines multiphysics simulation through a common engineering desktop that is used for pre- and postprocessing of multiple disciplines. Through this integrated platform, you can more easily perform multiphysics simulations such as thermal-fluid, thermo-mechanical, fluid-structure interaction, vibroacoustics, aero-vibro-acoustics, electromagnetic-thermal, and electromagnetic-vibro-acoustic. Simcenter 3D also supports both weak and strong coupling depending on the physics types involved.

## One integrated platform for multiphysics

Simcenter 3D combines all CAE solutions in one integrated platform and enables you to take advantage of industry-standard solvers for a full range of applications. This integration enables you to implement a streamlined multi-physical development process making multiphysics analysis safer, more effective and reliable.

This enables product developers to comprehend the complicated behavior that affects their designs. Understanding how a design will perform once in a tangible form, as well as knowledge of the strengths and weaknesses of different design variants, promotes innovation in the product development process. This results in better products that fulfill functional requirements and provide target customers with a safe and durable solution.

## Enabling multiphysics analysis

Realistic simulation must consider the real-world interactions between physics domains. Simcenter 3D brings together world-class solvers in one platform, making multiphysics analysis safer, more effective and reliable. Results from one analysis can be readily cascaded to the next.

Various physics domains can be securely coupled without complex external data links. You can easily include motion-based loads in structures and conduct multibody dynamic simulation with flexible bodies and controls, vibro-acoustic analysis, thermomechanical analysis, thermal and flow analysis and others that are strongly or weakly coupled. You can let simulation drive the design by constantly optimizing multiple performance attributes simultaneously.

## Quickening the pace of multiphysics analysis

With the help of Simcenter 3D Engineering Desktop, multiphysics models are developed based on common tools with full associativity between CAE and computer-aided design (CAD) data. Any existing analysis data can be easily extended to address additional physics aspects by just adapting physical properties and boundary conditions, but keeping full associativity and reusing a maximum of data.

## Industry applications

Simcenter 3D multiphysics solutions can help designers from many industries achieve a better understanding of the complex behavior of their products in real-life conditions, thereby enabling them to produce better designs.

### Aerospace and defense

- Airframe
  - Thermal/mechanical temperature and thermal stress for skin and frame
  - Vibro-acoustics for cabin sound pressure stemming from turbulent boundary layer loading of the fuselage
  - Flow/aero-acoustics for cabin noise occurring in climate control systems
  - Thermal/flow for temperature prediction in ventilation
  - Curing simulation for composite components to predict spring-back distortion
- Aero-engine
  - Thermal/mechanical temperature and thermal stress/distortion for compressors and turbines
  - Thermal/flow for temperature and flow pressures for engine system
  - Flow/aero-acoustic for propeller noise
  - Electromagnetic/vibro-acoustics for electric motor (EM) noise in hybrid aircraft
  - Electromagnetic/thermal for the electric motor
- Aerospace and defense
  - Satellite: Thermal/mechanical orbital temperatures and thermal distortion
  - Satellite: Vibro-acoustic virtual testing of spacecraft integrity due to high acoustic loads during launch
  - Launch vehicles: Thermal/mechanical temperature and thermal stress for rocket engines

### Automotive – ground vehicles

- Body
  - Vibro-acoustics for cabin noise due to engine and road/tire excitation
  - Flow/vibro-acoustics for cabin noise due to wind loading
  - Thermal/flow for temperature prediction and heat loss in ventilation

- Powertrain/driveline
  - Vibro-acoustics for radiated noise from engines, transmissions and exhaust systems
  - Thermal/flow for temperature prediction in cooling and exhaust systems
  - Electromagnetic/vibro-acoustic for EM noise
  - Electromagnetic/thermal for the electric motor performance analysis

### Marine

- Propulsion systems
  - Vibro-acoustics for radiated noise from engines, transmissions and transmission loss of exhaust systems
  - Flow/acoustics to predict acoustic radiation due to flow induced pressure loads on the propeller blades
  - Thermal/flow for temperature prediction in piping systems
  - Hull stress from wave loads
  - Electromagnetic/thermal analysis for electric propulsion systems

### Consumer goods

- Packaging
  - Thermal/flow for simulating the manufacture of plastic components
  - Mold cooling analyses

### Electronics

- Electronic boxes
  - Thermal/flow for component temperature prediction and system air flow in electronics assemblies and packages
  - Flow/aero-acoustics noise emitted from cooling fans due to flow-induced pressure loads on fan blades
- Printed circuit boards
  - Thermal/mechanical for stress and distortion

# Making multiphysics simulation more effective and reliable

Using Simcenter 3D enables you to map results from one solution to a boundary condition in a second solution. Meshes can be dissimilar and the mapping operation can be performed using different options.

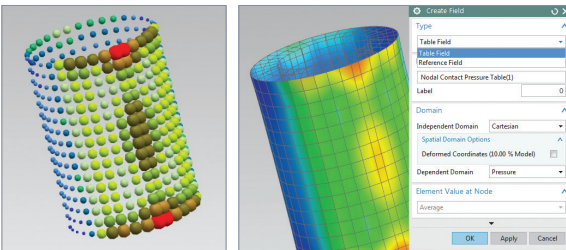
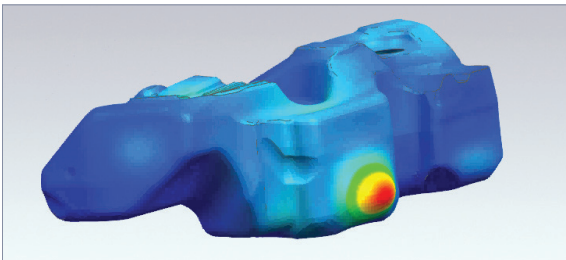

## Benefits

- Make multiphysics analysis more effective and reliable by using a streamlined development process within an integrated environment

## Key features

- Create fields from simulation results and use them as a boundary conditions: a table or reference field, 3D spatial at single time step or multiple time steps, scalar (for example, temperature) and vector (for example, displacement)
- Use pressure and temperature results from Simcenter 3D Thermal Multiphysics in Simcenter Nastran analysis
- Leverage displacement results from Simcenter Nastran for acoustics finite element method (FEM) and boundary element (BEM) computations
- Employ pressure and temperature results from Simcenter STAR-CCM+™ software for aero-vibroacoustics analysis
- Exploit stator forces results from electromagnetics simulation for vibro-acoustics analysis
- Results from third-party solvers can also be used for mapping: ANSYS, ABAQUS, MSC Nastran, LS-DYNA

# Coupling multiphysics simulation with flow and thermal problems

Simcenter 3D Thermal Multiphysics is a powerful and comprehensive solution for computational fluid dynamics (CFD) problems. Seamlessly combining the capabilities thermal and flow solvers, you can investigate a wide range of multiphysics scenarios involving strong coupling of fluid flow and heat transfer. This environment delivers a consistent look and feel for performing multiphysics simulations, so the user can easily build coupled solutions on the same mesh using common element types, properties and boundary conditions, as well as solver controls and options.

## Benefits

- Gain insight through coupled thermo-fluid multiphysics analysis
- Achieve faster results by using a consistent environment that allows you to quickly move from design to results

## Key features

- Consider complex phenomena related to conjugate heat transfer
- Thermally connect disjoint and dissimilar mesh faces and edges
- Connect dissimilar fluid meshes at interfaces between complex assemblies
- Speed up solution time with parallel calculations
- Couple 1D to 3D flow submodels to simulate complex systems
- Easily include mechanical effects with Simcenter Nastran to perform coupled thermal-fluid-structural simulations using the same model
- Live results post-processing and solver parameters control during solve

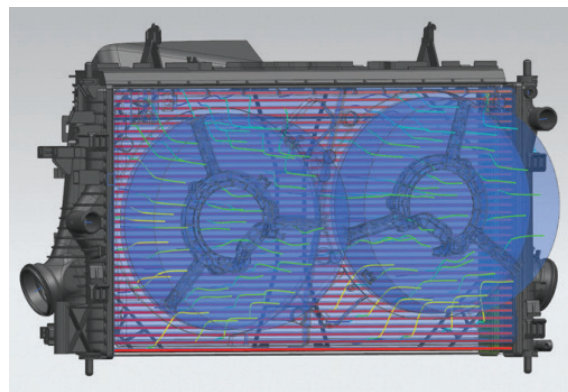
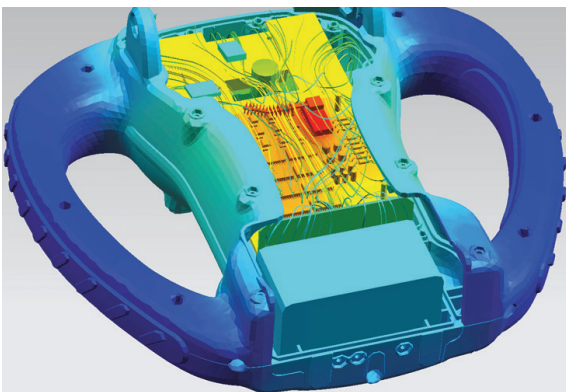

# Coupling multiphysics simulation of mechanical, thermal, and flow problems

Simcenter 3D Multiphysics leverages the structural physics of Simcenter Nastran with the thermal and flow physics of Simcenter 3D Thermal Multiphysics.

Simcenter Nastran is an industry standard solver for linear, nonlinear, and dynamic structural solutions. Simcenter 3D Thermal Multiphysics is a powerful and comprehensive solution for thermal and computational fluid dynamics (CFD) problems.

With Simcenter 3D Multiphysics users have a single easy-to-use environment for setting up solutions that couple any of combination these three physics – structures, thermal, and flow. The environment delivers a consistent look and feel for performing multiphysics simulations, so the user can easily build coupled solutions on a single mesh using common element topologies, properties and boundary conditions, as well as solver controls and options.

You can build the solution by systematically considering single physics first to validate their performance, and then adding other physics to build to the desired tightly coupled cosimulation solution.

The solution has a wide range of control capabilities to consider steady-state and transient effects. With the structural solution, you can span the range of basic linear elastic solutions to fully nonlinear with contact, plasticity, and large displacement effects – all of which can be coupled with the thermal and flow effects inherent in the system.

## Benefits

- Extend the mechanical, thermal and flow solution capabilities in Simcenter 3D to simulate complex phenomena with a comprehensive set of modeling tools
- Reduce costly physical prototypes and product design risk with high-fidelity thermal-mechanical simulation
- Gain further insight about the physics of your products
- Leverage all the capabilities of the Simcenter 3D integrated environment to make quick design changes and provide rapid feedback on thermal performance

## Key features

- Advanced simulation options for coupled thermomechanical analysis of turbomachinery and rotating systems
- Tightly-coupled thermomechanical analysis with Simcenter Nastran for axisymmetric, 2D, 3D, and mixed 2D-2D axisymmetric-3D representations
- Combines Simcenter Nastran multi-step nonlinear solution with industry-standard Simcenter 3D thermal and flow solvers
- Easily include flow effects with the integrated CFD solver inside Simcenter 3D Thermal Multiphysics to perform coupled thermal-fluid structural simulations using the same model
- Live results post-processing & solver parameters control during solve

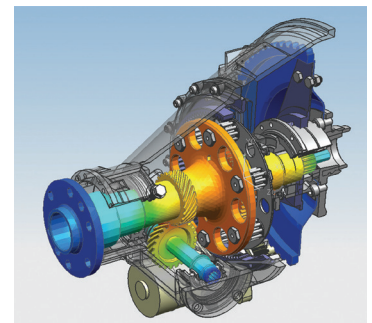
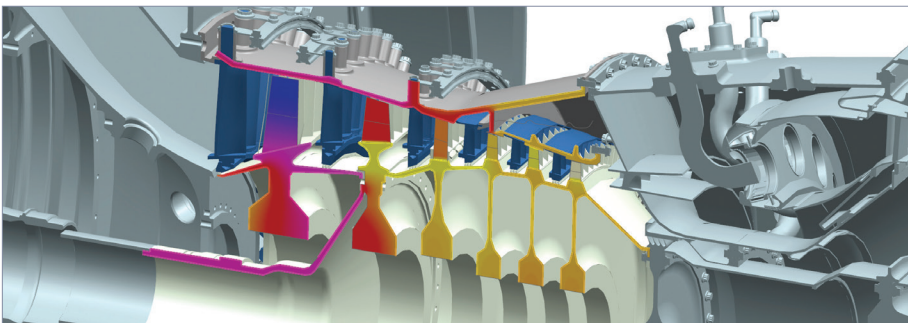

# Coupled multiphysics simulation involving dynamics and acoustics

The Simcenter Nastran software Advanced Acoustics module extends the capabilities of Simcenter Nastran for simulating exterior noise propagation from a vibrating surface using embedded automatically matched layer (AML) technology. Simcenter Nastran is part of the Simcenter portfolio of simulation tools, and is used to solve structural, dynamics and acoustics simulation problems. The Simcenter Nastran Advanced Acoustics module enables fully coupled vibro-acoustic analysis of both interior and exterior acoustic problems.

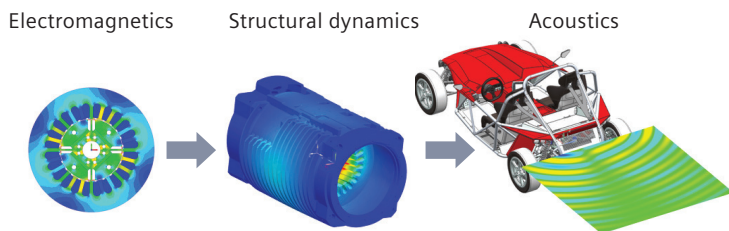

## Benefits

- Easily perform both weakly and fully coupled vibro-acoustic simulations
- Simulate acoustic problems faster and more efficiently with the next-generation finite element method adaptive order (FEMAO) solver

## Key features

- Simulate acoustic performance for interior, exterior or mixed interior-exterior problems
- Correctly apply anechoic (perfectly absorbing, without reflection) boundary conditions
- Correctly represent loads from predecessor simulations: mechanical multibody simulation, flow-induced pressure loads on a structure and electromagnetic forces in electric machines
- Include porous (rigid and limp frames) trim materials in both acoustic and vibro-acoustic analysis
- Request results of isolated grid or microphone points at any location
- Define infinite planes to simulate acoustic radiation from vibrating structures close to reflecting ground and wall surfaces

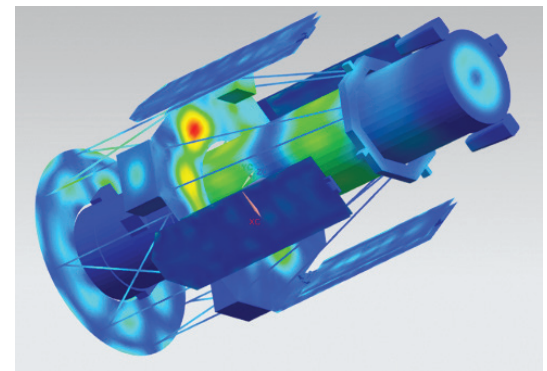
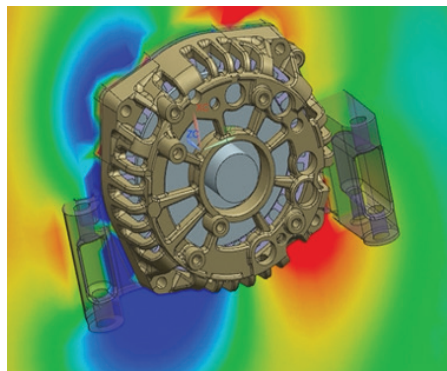
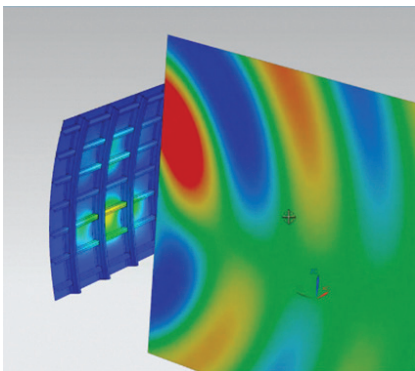

# Simcenter 3D

## Aero-Vibro-Acoustics

This product supports creating aero-acoustic sources close to noise-emitting turbulent flows and allows you to compute their acoustic response in the environment (exterior or interior); for example, for noise from heating ventilation and air conditioning (HVAC) or environmental control system (ECS) ducts, train boogies and pantographs, cooling fans and ship and aircraft propellers. The product also allows you to define wind loads acting on structural panels, leading to vibro-acoustic response; for instance, in a car or aircraft cabin.

### Module benefits

- Derive lean, surface pressure-based aero-acoustic sources for steady or rotating surfaces
- Scalable and user-friendly load preparation for aero-vibro-acoustic wind-noise simulations
- Import binary files with load data directly into Simcenter Nastran for response computations

### Key features

- Conservative mapping of pressure results from CFD to the acoustic or structural mesh
- Equivalent aero-acoustic surface dipole sources
- Equivalent aero-acoustic fan source for both tonal and broadband noise
- Wind loads, using either semi-empirical turbulent boundary layer (TBL) models or mapped pressure loads from CFD results

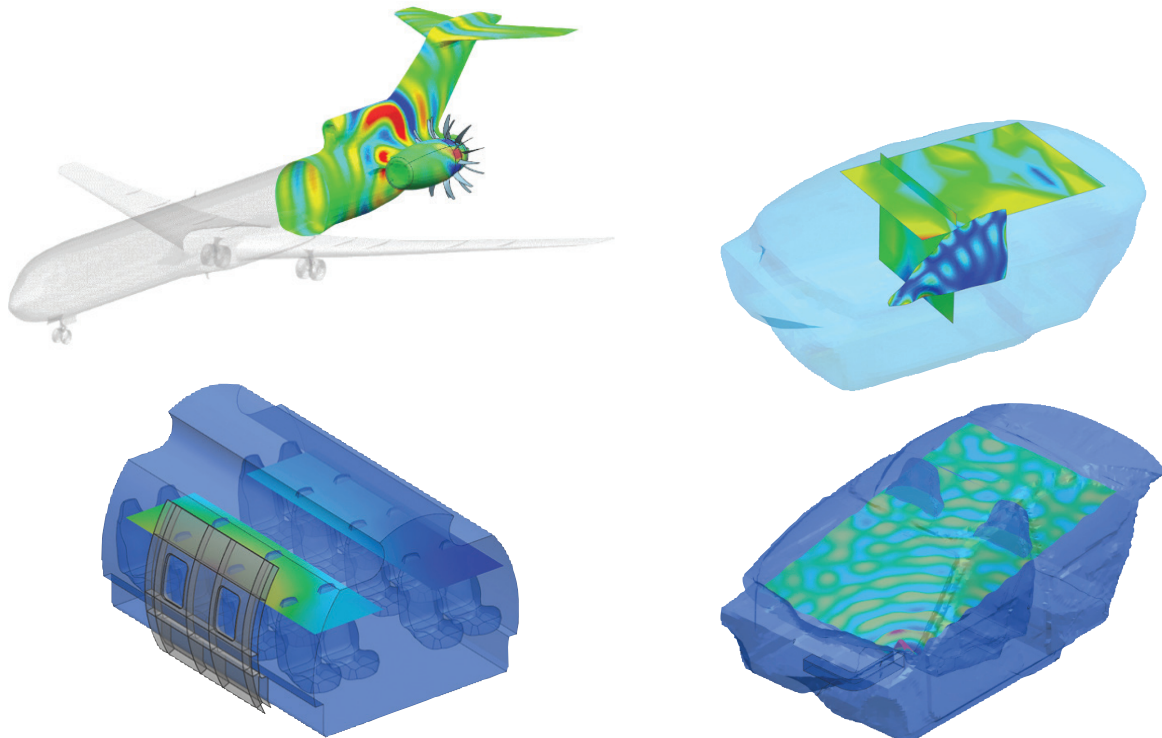

# Simcenter 3D

## Electromagnetics/Thermal

Simcenter MAGNET™ Thermal software can be used to accurately simulate temperature distribution due to heat rise or cooling in the electromechanical device. Simcenter 3D seamlessly couples with the Simcenter MAGNET solver to provide further analysis: You can use power loss data from Simcenter MAGNET as a heat source and determine the impact of temperature changes on the overall design and performance.

Each solver module is tailored to different design problems and is available separately for both 2D and 3D designs.

### Module benefits

- Achieve higher fidelity predictions by taking temperature effects into account in electromagnetic simulations
- Leverage highly efficient coupling scenarios

### Key features

- Simulates the temperature distributions caused by specified heat sources in the presence of thermally conductive materials
- Couples with Simcenter MAGNET solver for heating effects due to eddy current and hysteresis losses in the magnetic system

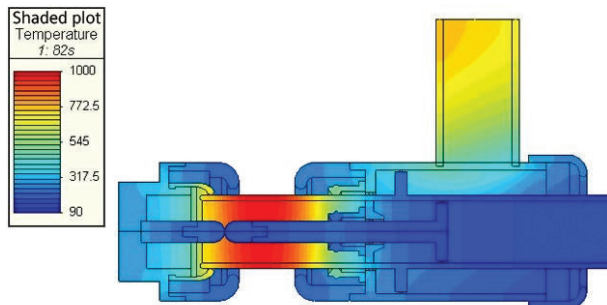

# Capabilities chart

General capabilities	Types of coupling		Solvers						
	One-Way	Two-Way	Simcenter Nastran (Structures and FEM Acoustics)	Simcenter 3D Acoustics (BEM, ABEM, Ray Acoustics)	Simcenter 3D Thermal Multiphysics	Simcenter 3D Electromagnetics	Simcenter 3D Motion	Simcenter STAR-CCM+ Simcenter FLOEFD	Third-party solvers
<b>Legend</b> • = type of coupling supported V = vibration A = acoustics F = flow T = thermal  S = structural/mechanical E = electromagnetics FX = flexible body MBD = multibody dynamics/motion C = controls									
<b>Supported analysis types</b>									
Vibro-acoustics (V-A)	•	•	V-A	A			V		V
Thermal-mechanical (T-S)	•	•	S		T				
Flow-thermal (F-T)	•	•			T-F			F	F
Fluid-structure interaction (F-S)	•		S		F			F	
Thermal-fluid-structure interaction	•	•	S		T-F			F	
Aero-acoustics (F-A)	•		A					F	F
Aero-vibro-acoustics (F-V-A)	•	•	V-A	A				F	F, V
Thermal-electromagnetics (T-E)	•	•				T-E			
Vibro-acoustics - electromagnetics (V-A-E)	•		V-A	A		E			E, V
Flexible multibody dynamics (FX-MBD)	•		FX				MBD		FX
Motion-control simulation (MBD-C)		•					MBD	C	C

## Siemens Digital Industries Software

[siemens.com/software](https://www.siemens.com/software)

Americas 1 800 498 5351

Europe 00 800 70002222

Asia-Pacific 001 800 03061910

For additional numbers, click [here](#).