

DIGITAL INDUSTRIES SOFTWARE

Simcenter 3D for acoustics simulation

Optimizing the sound quality of products

Solution benefits

Accelerate creating acoustic simulation models from complex geometries based on CAD, a previous mesh or from scratch

Solve acoustics, vibro-acoustics and aero-acoustics efficiently from a single interface using powerful FEM/ BEM and ray acoustics solvers

Covers interior, exterior, mixed problems and support for all typical sources, boundary conditions and materials to realistically capture source generation and wave propagation

Supports multiple RPM problems for rotating machinery (e-drives, engines, gearboxes and rotating components) provided for preprocessing (synthesis of waterfall and order cut loads), solver and postprocessing (campbell, order cursors, etc.)

Interpret results easily using auralization in addition to visual plots and animations

Simcenter™ 3D software offers a comprehensive solution to minimize noise and optimize the sound quality of products. Dedicated acoustic modeling capabilities, efficient solvers and easy-to-interpret visualization and auralization tools allow you to quickly gain insight into a design's acoustic performance for uncoupled acoustics, coupled vibro-acoustics and aero-acoustic applications. Simcenter is part of the Siemens Xcelerator business platform of software, hardware and services.

Accelerate acoustic meshing and modeling

Advanced features, such as surface wrapping, convex meshing, mesh thickening and the ability to create hybrid (hexa-tetra) meshes, help you accelerate acoustic meshing processes more than traditional preprocessors. The availability

of various material models for both structures and fluids, plus the wide variety of structural and acoustic boundary conditions and loads allow you to efficiently set up your analysis.

Deliver high-fidelity vibro-acoustic simulations in the most efficient way

Simcenter 3D increases the realism in your simulations by providing support for loads or source creation from test data and predecessor multibody or computational fluid dynamics (CFD) simulations.



Acoustics

SIEMENS

[siemens.com/simcenter3d](https://www.siemens.com/simcenter3d)

Simcenter 3D for acoustics simulation

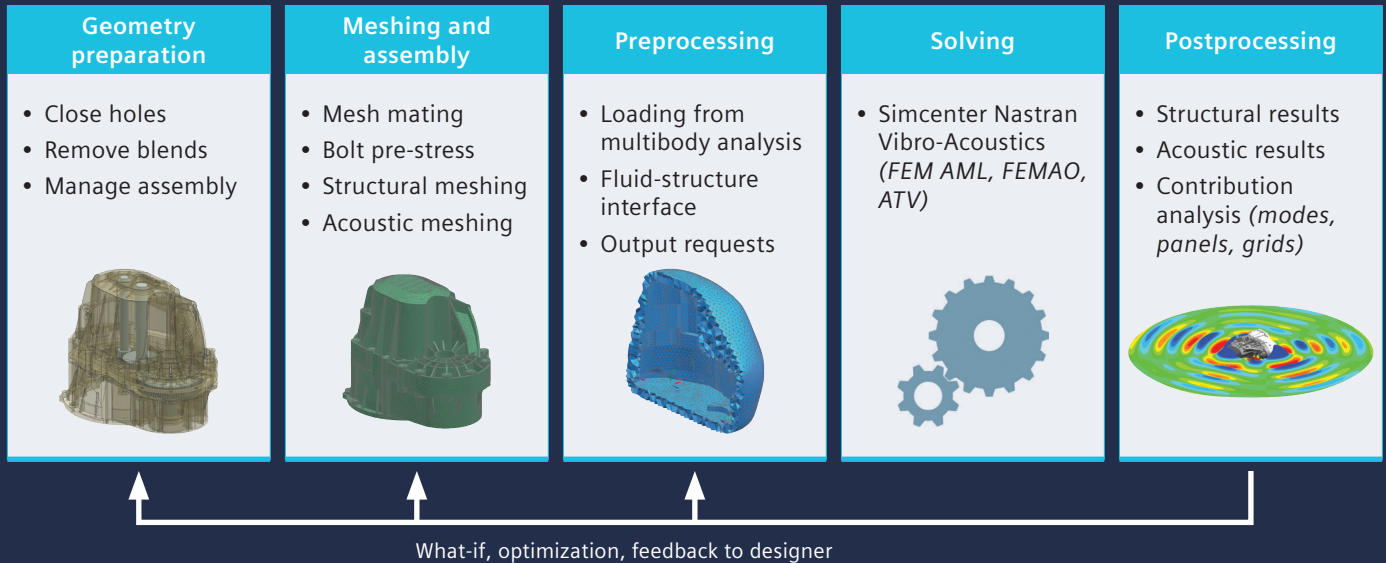

Simcenter Nastran software is used to rapidly solve complex interior and exterior acoustics problems thanks to key features like automatically matched layer (AML) and finite element adaptive order (FEMAO) technology, which allow you to use small fluid meshes with an optimal number of degrees-of-freedom (DOF) per frequency.

Faster design-analysis iterations with CAD-CAE-test associativity

Simcenter 3D seamlessly links to computer-aided design (CAD), computer-aided engineering (CAE) and even test data. Any design modification can be easily introduced to the structural and/or acoustic model, eliminating multiple conversions between [file formats](#) and recreating models.

Gain instantaneous insight with acoustic-specific post-processing

Simcenter 3D provides easy-to-interpret and intuitive postprocessing tools to investigate noise as a sound pressure level (SPL), acoustic power or directivity. Path, modal and panel contribution analysis helps to rapidly identify the important noise sources and their propagation.

In addition to visual postprocessing capabilities, Simcenter 3D offers auralization capabilities that let you actually listen to acoustic simulation results to evaluate noise contributions and sound quality for different versions of your product design.

Providing a platform for multidiscipline simulation

The Simcenter 3D acoustics solution is part of a larger, integrated multidiscipline simulation environment with the Simcenter 3D Engineering Desktop at the core for centralized pre- and postprocessing for all Simcenter 3D solutions. This integrated environment helps you to achieve faster CAE processes and streamline multidiscipline simulations that integrate acoustics and other disciplines, like e-drive noise predictions based on electromagnetic (stator) and structural (gearbox bearing) loads computed in Simcenter 3D Electromagnetics and Motion.

Industry applications

Since noise can impact health, and a quiet product is often perceived as higher in quality, companies are adopting efficient processes and tools to optimize the noise performance of their products.

Aerospace and defense

With Simcenter 3D, aviation engineers can predict cabin noise generated by turbulent boundary layers (TBL) on the fuselage or by aero-acoustic noise coming from the environmental control system (ECS). Exterior noise can be tackled using the high-end boundary element method (BEM), finite element method (FEM) and ray acoustics solvers. To assess the environmental noise footprint of drones and other urban air mobility craft, engineers can predict **propeller noise** on both a component level (aero-acoustic solutions based on CFD input) and at the level of far propagation, such as in a city scape (ray acoustics solution). Spacecraft engineers can reduce the risk of their acoustic verification tests by evaluating them virtually in Simcenter 3D.

Automotive and transportation

During vehicle development and improvement programs, the capabilities of Simcenter 3D can deliver noise, vibration and harshness (NVH) engineers with valuable insight into acoustic, vibro-acoustics and aero-acoustic noise contributions in the vehicle cabin and exterior environment for pass-by noise predictions or to design acoustic vehicle alerting systems (AVAS).

Consumer goods

Building powerful, high-quality speakers, silent vacuum cleaners and washing machines and other noise-free consumer goods requires advanced noise engineering and sound characterization features provided by Simcenter 3D.

Industrial machinery

Simcenter 3D acoustic modules provide the necessary features to evaluate machine-radiated noise, including capturing the effect of encapsulations with sound treatments.

Marine

Acoustic features of Simcenter 3D can be used to study complex underwater radiation from ship hulls, propellers and submarine hull reflections of sonar waves.

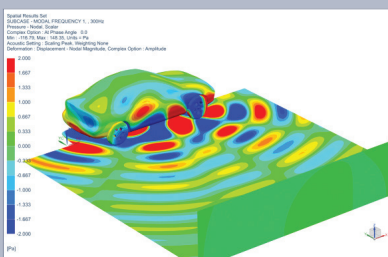
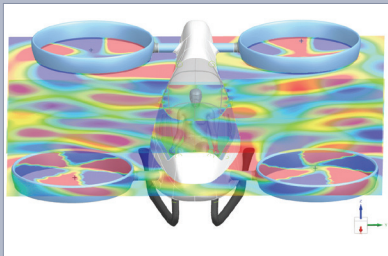
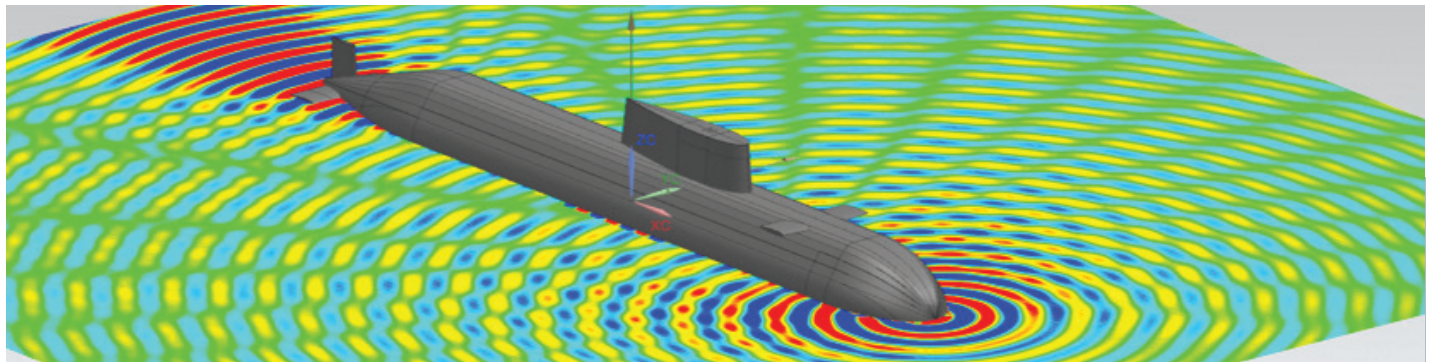

- Structural acoustics
- Aero-vibro-acoustics
- Component noise radiation
- Full vehicle scattering
- Cabin vibro-acoustics
- Transmission loss
- Room acoustics
- FEM/BEM/Ray acoustics

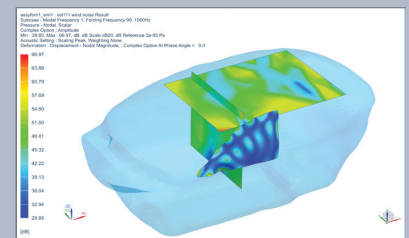
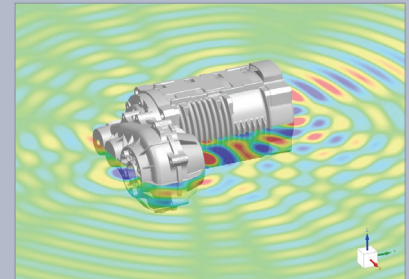

Simcenter 3D

Meshing for Acoustics

Using Simcenter 3D Meshing for Acoustics software helps you create meshes for FEM and BEM acoustic analysis. The module provides user-friendly, leading-edge functionalities to create an acoustic fluid mesh, both for interior as well as exterior acoustic applications, starting from an existing structural mesh or CAD geometry.

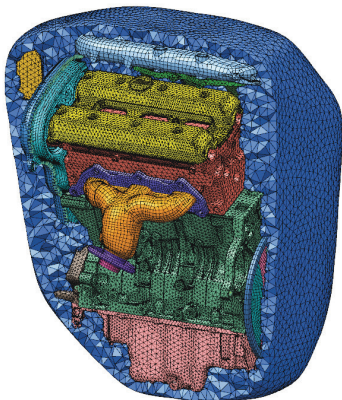
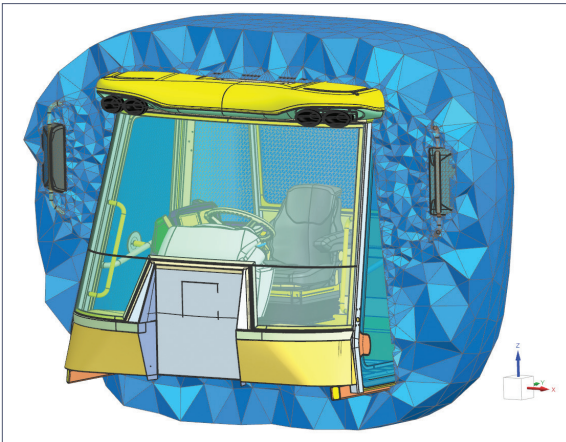

Module benefits

- Start from a structural FEM model or CAD geometry
- Accelerate the acoustic meshing process for complex geometries

Key features

- Hybrid mesh and polygon-based coarsening, hole-filling and rib-removal tools
- Interior and exterior surface-wrapping technology based on input of CAD or CAE model
- Easy creation of convex outer boundary surface to construct FEM meshes for exterior acoustics
- Hybrid hexa-dominant hexa and tetra mesher for fluid volumes facilitating efficient solving
- Structural shell mesh thickening (reverse of mid-surfacing) to derive boundary surfaces of FEM fluid cavities
- Automatic single step meshing for acoustic applications: component exterior noise radiation and panel transmission loss

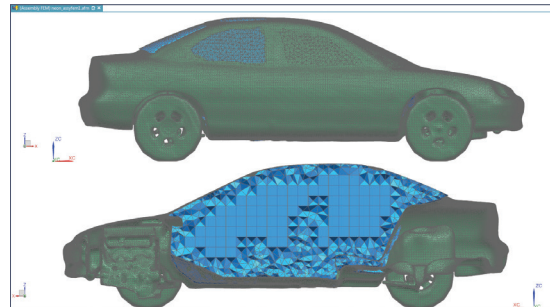

Simcenter Nastran Advanced Acoustics

Simcenter Nastran Advanced Acoustics software provides support for standard loads and boundary conditions, and key technologies like AML and FEMAO, to rapidly resolve acoustic simulations. It is well suited to study the acoustic radiation of components and pass-by noise of full vehicles, transmission loss of duct systems like intakes and exhausts or mufflers and transmission loss of panels.

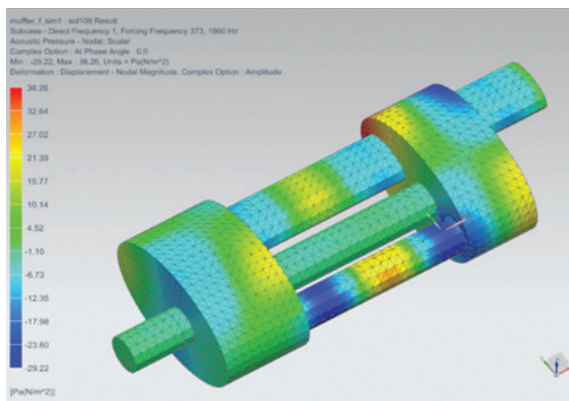

Module benefits

- Performs vibro-acoustic (SOL108/SOL111) simulations for interior or exterior noise
- Study exterior acoustics with lean FEM models thanks to embedded AML technology
- Efficiently simulate broadband acoustic problems using the adaptive FEMAO solver

Key features

- Support standard loads and boundary conditions, as well as specific acoustic boundary conditions like duct modes and acoustic diffuse field (random) loads
- Pressure loads on structural surfaces from other acoustic or CFD analysis
- Porous and temperature-dependent fluid materials, mean convective flow effects, frequency-dependent surface impedance and transfer admittance between pairs of surfaces
- Compute sound pressure, intensity and power for virtual microphones located inside or outside the meshed fluid volume

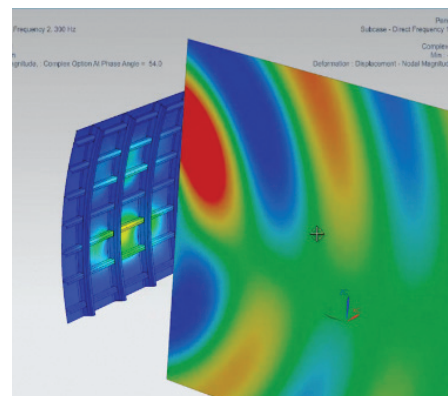
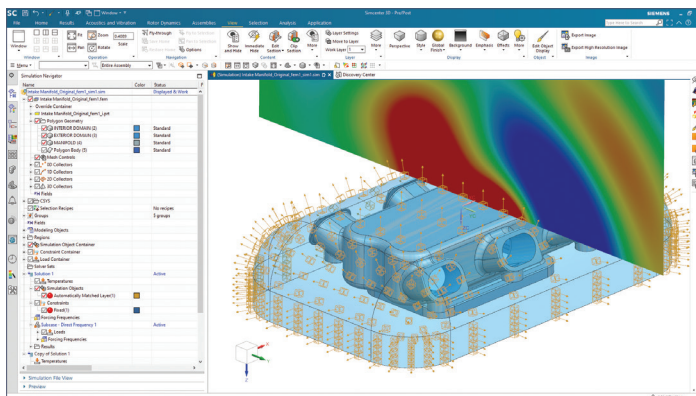

Simcenter Nastran Acoustics Trim

With the ongoing trend of electrification and light-weighting in the transportation industry, trim materials with sound absorbing capabilities are becoming more important. This means the need to simulate trim materials for acoustic performance is also increasingly important to ensure the trim can efficiently tackle noise problems at the higher frequencies that electric drives typically impose. Trim materials (visco-elastic and poro-elastic materials) are also found in other industries, like electronics. Using Simcenter Nastran Acoustics Trim helps you model acoustic trim treatments used to passively dampen sound using key technologies for accurate and efficient solving. Simcenter Nastran Acoustics Trim is well suited to study acoustic treatments of car panels (floor, door, dash), thermo-acoustic shields that are placed on top of powertrain components or even to assess the acoustic effects of foam filling in your over-ear headphones.

Module benefits

- Quickly analyze the impact of flat trim layers
- Reduce the computational costs for accurate solving with poro-elastic materials by benefiting from the fast and efficient FEMAO

Key features

- Equivalent transfer matrix calculation with vibro-acoustic transfer admittance and postprocessing of the alpha coefficients
- Full Biot formulation for accurate simulation of poro-elastic materials
- Adaptive order (AO) technology applied to poro-elastic materials
- Embedded vibro-acoustic coupling with poro-elastic meshes for both conformal and non-conformal meshes
- Computation of the dissipated powers through poro-elastic materials (structural, viscous, thermal losses)

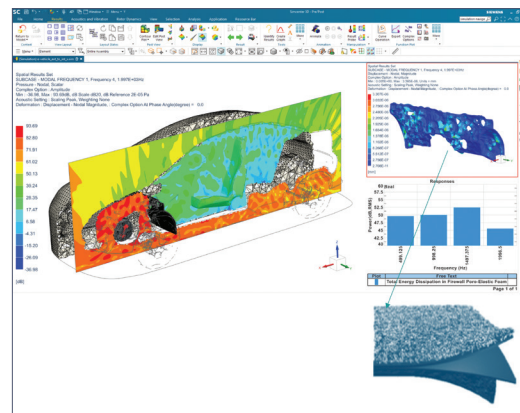
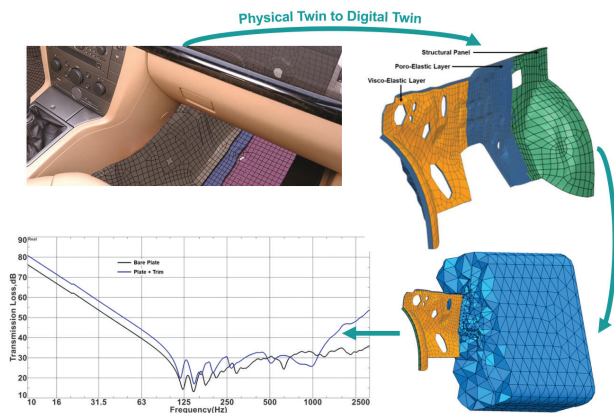

Simcenter 3D

Acoustic Transfer Vector

Simcenter 3D Acoustic Transfer Vector software supports computing the acoustic transfer vector (ATV), expressing the sensitivity of the pressure response at a virtual microphone per unit normal velocity at field points on a radiating surface. It can be re-used to quickly predict the acoustic response for any surface vibrations. Similarly, vibro-acoustic transfer vectors (VATV) express the sensitivity of microphone pressures for unit force applied at points on a structure. Also, VATV can be quickly reused for predicting the acoustic response to any force loading. Modal participation factors (MPFs) can also be used with ATVs in a modal acoustic transfer vector (MATV) context.

Module benefits

- Use ATV to compute noise from rotating machines with multiple revolutions per minute (RPM) loads up to 100 times faster
- Use VATV to quickly evaluate cabin noise due to multiple load cases of flow-induced pressure loads, like wind loads and turbulent boundary layers

Key features

- ATV results can be obtained from Simcenter Nastran, BEM and Ray Acoustic solutions
- ATV can be interpolated when used in a forced response context
- Evaluate acoustic pressure, power, panel, grid and modal contributions for ATV response

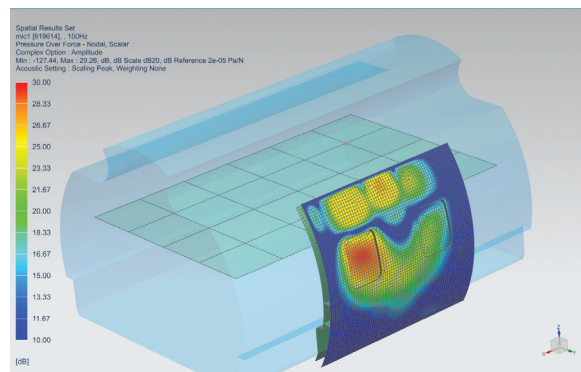
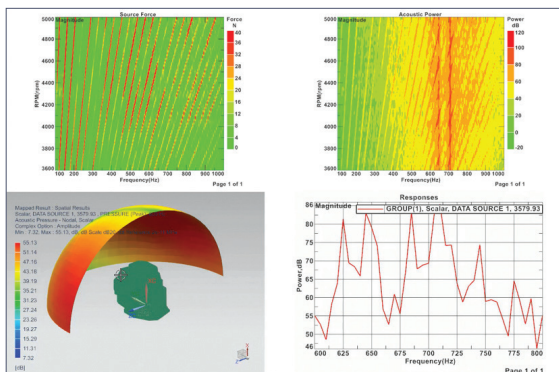

Simcenter 3D

Aero-Vibro-Acoustics

Simcenter 3D Aero-Vibro-Acoustics software supports creating aero-acoustic sources close to noise-emitting turbulent flows and allows you to compute their acoustic response in the exterior or interior environment; for example, for noise coming from heating, ventilation and air-conditioning (HVAC) units, environmental control system (ECS) ducts, train bogies and pantographs, cooling fans, ship and aircraft propellers and more. The product also allows you to define wind loads acting on structural panels, leading to a vibro-acoustic response; for instance, in a car or aircraft cabin.

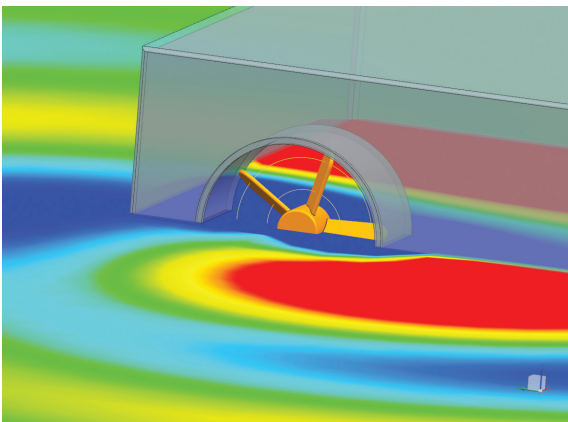
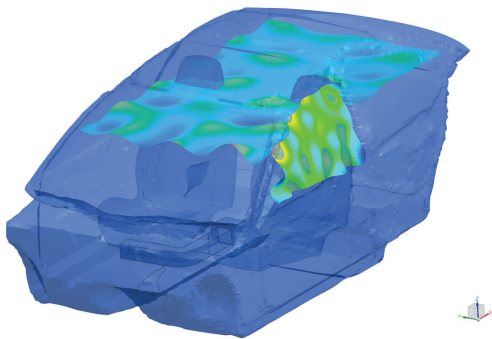

Module benefits

- Derive lean, surface pressure-based aero-acoustic sources for stationary and rotating surfaces
- Provide scalable and user-friendly load preparation for aero-vibro-acoustic wind noise simulations
- Import binary files with load data directly in Simcenter Nastran for response computation

Key features

- Conservative mapping of pressure results from CFD to the acoustic or structural mesh
- Equivalent aero-acoustic surface dipole and volume quadrupole sources
- Equivalent aero-acoustic fan sources for both tonal and broadband noise
- Wind loads, using either semi-empirical turbulent boundary layer models or mapped pressure loads from CFD results
- Aero-acoustics radiating sources on permeable surfaces

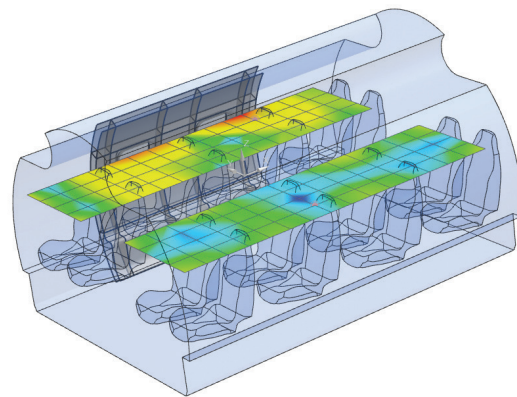

Simcenter 3D Load Identification

Leveraging Simcenter 3D Load Identification enables you to get accurate dynamics loadings of a structure. Operational loads are very important for accurate response prediction but are often impossible or difficult to measure directly.

This product offers several ways of identifying the operational forces from measured data, either by the mount stiffness method or an inverse matrix method. For instance, in an inverse matrix method, the operational vibration data can be measured in operational conditions and the transfer functions (FRFs) can be measured in controlled lab conditions or obtained from simulations. These data are then combined in an inverse load identification case.

In addition, Simcenter 3D Load Identification supports a modal expansion solution to create enriched vibration results on a full FE model based on measured vibrations at just a few locations.

Finally, a second method to derive structural surface vibrations is provided through inverse numerical acoustics, in which measured pressure responses at only a few points near the structure are used together with acoustic transfer vectors to identify the full surface vibrations. The obtained vibration field can then be used further for acoustic radiation analysis.

Module benefits

- Determine operational forces or vibrations that are difficult or impossible to measure directly
- Get a more realistic simulation by applying more accurate loading
- Combine measured loading data with FE simulations

Key features

- Mount method to estimate mount forces by combining operational vibration data at each side of the mount and mount stiffness data
- Inverse matrix method by a combination of operational measurements and transfer functions, based on all measured data or a combination of operation measurements and simulation data
- Straightforward application and reuse of the identified forces or vibrations to the simulation model

Test



Mount stiffness method

- Operational vibrations on both ends of the mounts are measured
- Mount stiffness FRFs measured in lab



$$F(\omega) = K(\omega)[X_s(\omega) - X_t(\omega)]$$

Inverse matrix method

- Operational vibrations are measured
- FRFs measured in lab

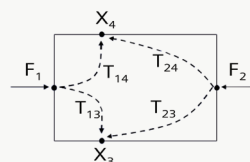

$$\begin{bmatrix} F_1 \\ F_2 \end{bmatrix} = \begin{bmatrix} T_{13} & T_{23} \\ T_{14} & T_{24} \end{bmatrix}^{-1} \begin{bmatrix} X_3 \\ X_4 \end{bmatrix}$$

Simcenter 3D Environment for BEM Acoustics

Simcenter 3D Environment for BEM Acoustics software supports generating a ready-to-run acoustic or vibro-acoustic simulation model for direct BEM and indirect BEM solvers, and provides comprehensive postprocessing tools to analyze the acoustic or vibro-acoustic results.

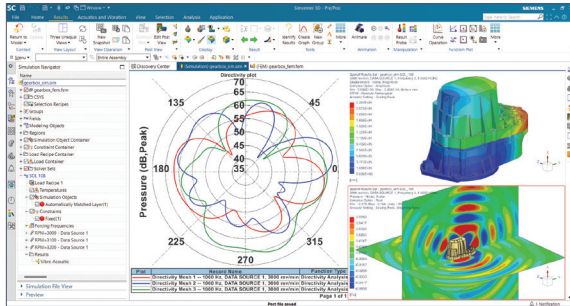
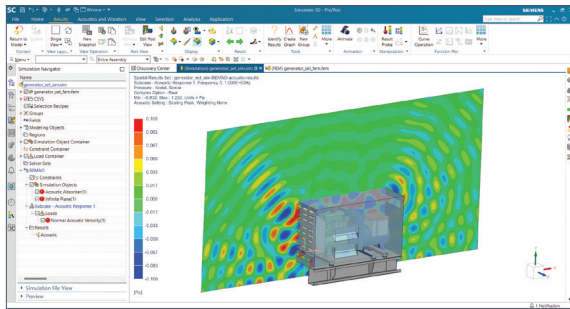

Module benefits

- Streamline acoustic BEM model creation for both standard and BEMAO solvers in a user-friendly interface
- Support pure acoustic problems as well as weakly or fully coupled vibro-acoustics response via modal-based definition of the structure
- Leverage dedicated postprocessing capabilities to improve users' engineering insight and productivity

Key features

- Provide all standard structural and acoustic loads and boundary conditions to describe your vibro-acoustic problems accurately
- Prepare deterministic as well as random acoustics and vibro-acoustics analysis
- Standard postprocessing of acoustic results like pressure and acoustic power and structural vibrations
- Dedicated diagnostic plots showing panel contributions and structural modal contributions to the acoustic pressure or power

Simcenter 3D

Acoustics BEM solver

The Simcenter 3D Acoustics BEM solver is used to predict the acoustic response in both enclosed and unbounded domains using a mesh for only the boundary of the fluid domain. Vibro-acoustic analysis is supported by coupling the acoustic fluid with a structural modal model. Structural vibrations can also be imposed on the BEM fluid using weak vibro-acoustic coupling.

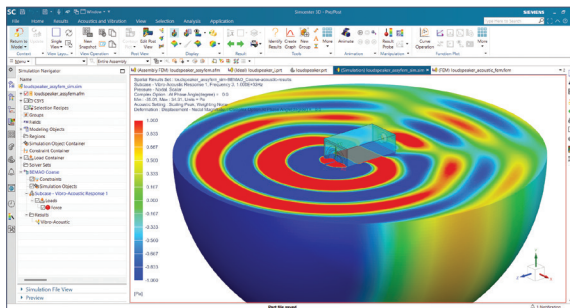
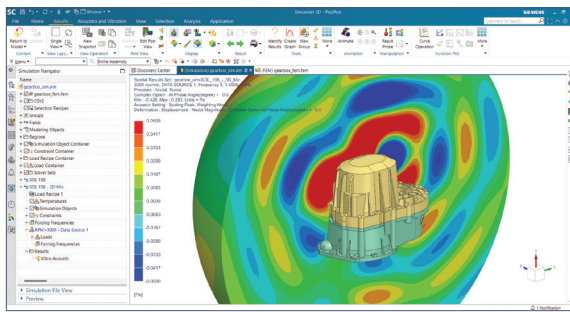

Module benefits

- Fast and efficient BEM solvers for solving both purely acoustic as well as vibro-acoustic problems
- A multitude of acoustic and structural loads and boundary conditions are supported for an accurate description of your vibro-acoustic simulation model
- Automatic BEM model corrections for free and junction edges

Key features

- Direct and indirect acoustic uncoupled solutions
- Indirect vibro-acoustic, weakly coupled and strongly coupled solutions
- Deterministic as well as random acoustics and vibroacoustics analysis
- Returns standard acoustic and structural response results
- Provides structural panel contributions and modal contributions to the acoustic pressure or power
- Direct and iterative solving

Simcenter 3D

Acoustics BEMAO solver

The Simcenter 3D Acoustics BEMAO Solver is used to predict the acoustic response in both enclosed and unbounded domains using a mesh for only the boundary of the fluid domain, but with a significant solution speed-up when compared to the Simcenter 3D Acoustics BEM Solver. The faster solution time comes from the AO technology in the BEMAO solver that relies on high-order shape functions and an a-priori error estimator to efficiently reduce the number of degrees-of-freedom. Vibro-acoustic analysis is supported by coupling the acoustic fluid with a structural modal model. Structural vibrations can also be imposed on the BEM fluid using weak vibro-acoustic coupling.

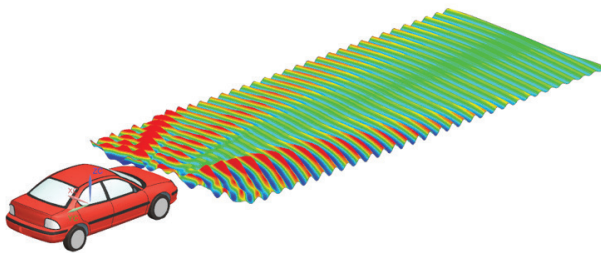

Module benefits

- Quickly and efficiently simulate broadband acoustic and vibro-acoustic problems without having to use a very fine mesh
- Accurately represent vibro-acoustics models using a multitude of acoustic and structural loads and boundary conditions
- Accurately account for BEM-specific model hurdles (for example, free/junction edges, quadrature rules, near-field singularities)

Key features

- Automatic BEMAO model corrections for free and junction edges; improved automatic quadrature rules; better handling of near-field singularities; accelerated fast-multipole matrix assembly
- Indirect acoustic uncoupled solutions
- Indirect vibro-acoustic, weakly coupled and strongly coupled solutions
- Deterministic as well as random acoustics and vibro-acoustics analysis
- Provides structural panel contributions and modal contributions to the acoustic pressure or power

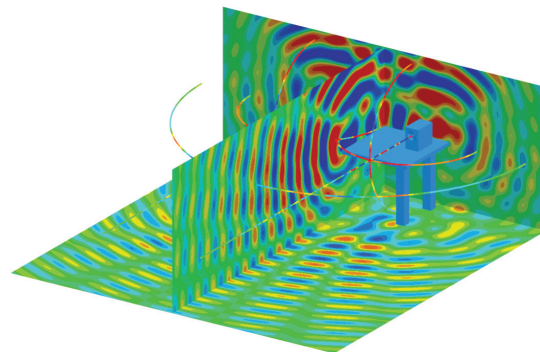

Simcenter 3D

Acoustics Time Domain BEM solver

Using Simcenter 3D Acoustics Time Domain BEM software enables BEM solutions to solve transient acoustic and vibro-acoustic phenomena. As opposed to the frequency-domain based BEM solvers, leveraging Simcenter 3D Acoustics Time Domain BEM Solver gives the possibility to solve problems involving impulsive short time excitation signals in the time domain. This BEM solver is well suited for applications such as parking sensor design and door slam analysis.

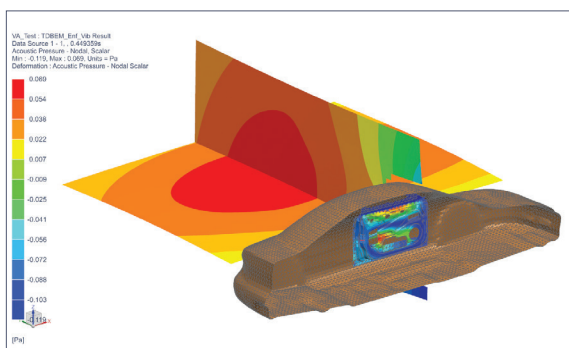
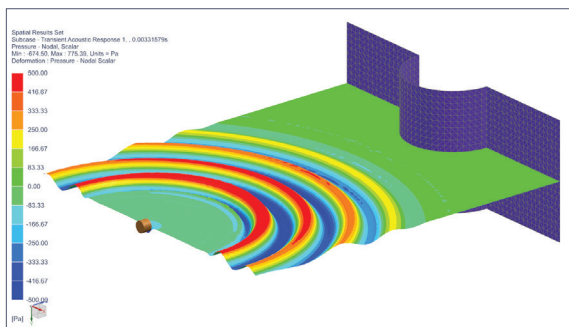

Module benefits

- Allows for accurate modeling of transient infinite domain problems
- Provides solutions for purely acoustics and vibro-acoustic problems
- Provides a fast and efficient solver in the time domain, even when using large models

Key features

- Dedicated solver environment Simcenter 3D Acoustics Transient BEM for time domain BEM computations, including two analysis types: transient acoustic and transient vibro-acoustic
- Supports multiple loads and boundary conditions
 - Transient acoustic: acoustic monopole, plane wave, infinite plane, acoustic absorber, transfer admittance
 - Transient vibro-acoustic: force applied on structure (with mode set representation), pre-computed vibrations, infinite plane, acoustic absorber, transfer admittance, panel

Simcenter 3D Acoustics HPC

A high-performance computing (HPC) package is available. Using Simcenter 3D Acoustics HPC software enables you to execute acoustic FEM or BEM computations in multiprocessing mode on the parallel hardware of your choice. Parallel calculation sequences are implemented using the message passing interface (MPI) communication standard. In the case of FEM vibro-acoustics, this product embeds the distributed memory parallelization (DMP) capability of Simcenter Nastran.

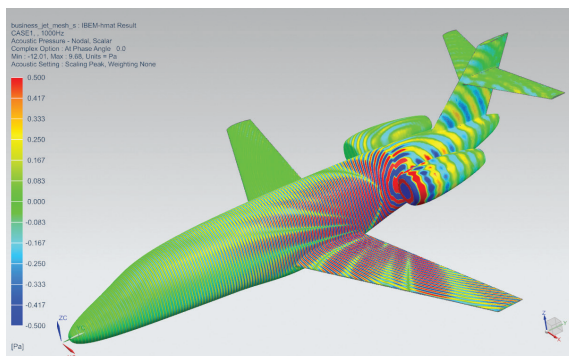
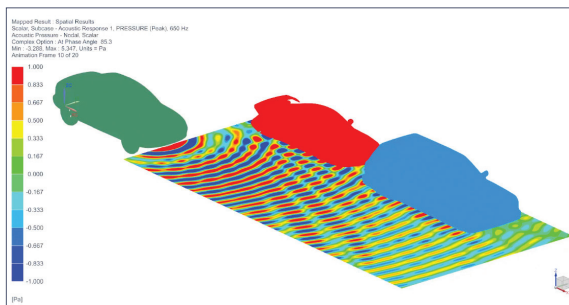

Module benefits

- Accelerates acoustic computations using multithreading, shared memory parallelization (SMP), multiprocessing and DMP
- This product supports high-performance computing for Simcenter 3D Acoustics FEM and BEM solvers

Key features

- Solvers can run in high-performance computing mode on multi-node clusters as well as on multi-core workstations
- Allows you to tackle problems with many frequencies with DMP for which a near-linear parallel speed up can be expected

Simcenter 3D

Ray Acoustics

Simcenter 3D Ray Acoustics is used to predict acoustic responses with very high frequencies and for very large geometries, in both enclosed and unbounded domains. Unlike FEM or BEM acoustic solvers, ray acoustics solutions are not based on a fine discretization of the domain. Therefore, the solution is not bounded by an upper frequency limit or the model size and solving is done orders of magnitude faster than FEM or BEM.

Simcenter 3D Ray Acoustics integrates an engineering environment in Simcenter 3D to generate and postprocess a ray acoustic model, as well as a ray acoustic solver, which is the ICARE solver from the Scientific and Technical Center for Building (CSTB).

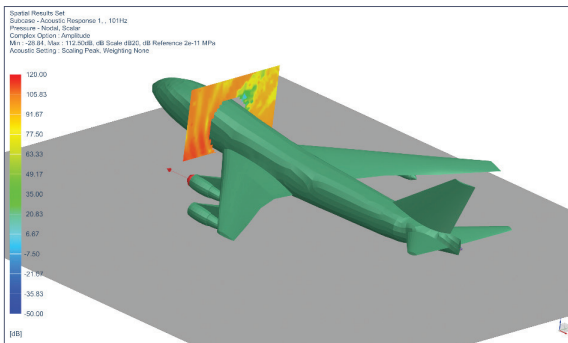
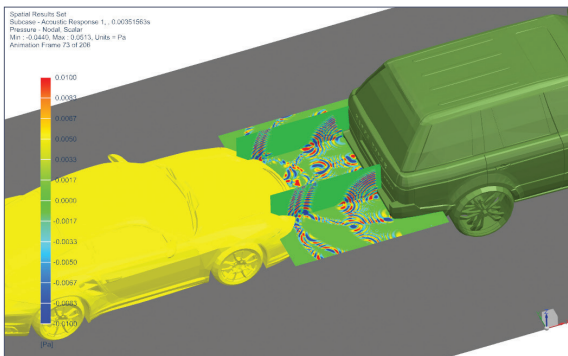

Module benefits

- Solve high-frequency acoustic simulations for large models in a fraction of the time required with FEM or BEM solvers
- A coarse mesh can be used provided it captures the model's geometry, simplifying model creation
- Standard acoustic loads and boundary conditions are supported for an accurate description of the simulation model
- Advanced results and postprocessing to explore ray path arrivals, source contributions, binaural acoustic responses or sound quality criteria

Key features

- Returns acoustics results in both the frequency and time domain
- Simulates the propagation of acoustic energy with adaptive beam tracing technology
- Accurately simulates reflections on curved surfaces despite the coarse mesh discretization
- Captures multi-order diffraction effects and creeping waves
- Captures late reflections and diffusion effects with particle tracing technology
- Supports standard acoustic loads including point source directionality
- Dedicated solution types to calculate acoustic FRFs and ATVs to support advanced NVH workflows (see Simcenter 3D Acoustic Transfer Vector page)

Simcenter 3D Acoustics Auralization

Leveraging Simcenter 3D Acoustics Auralization immerses you into a virtual acoustic environment where you can evaluate the acoustic performance of your designs by listening to simulation results rather than only looking at plots and curves. This tool creates listening scenarios based on simulated or externally recorded sources and simulated transfer functions obtained from either the Simcenter 3D Ray Acoustics or Simcenter 3D Acoustics BEM or FEM solutions. With Simcenter 3D Acoustics Auralization, you can visualize the resulting time data, listen to the scenario and make changes to the individual tracks to improve the sound quality of your product. Moreover, using the embedded sound quality metrics tool, you can quantitatively evaluate the sound quality based on dedicated loudness and sharpness metrics.

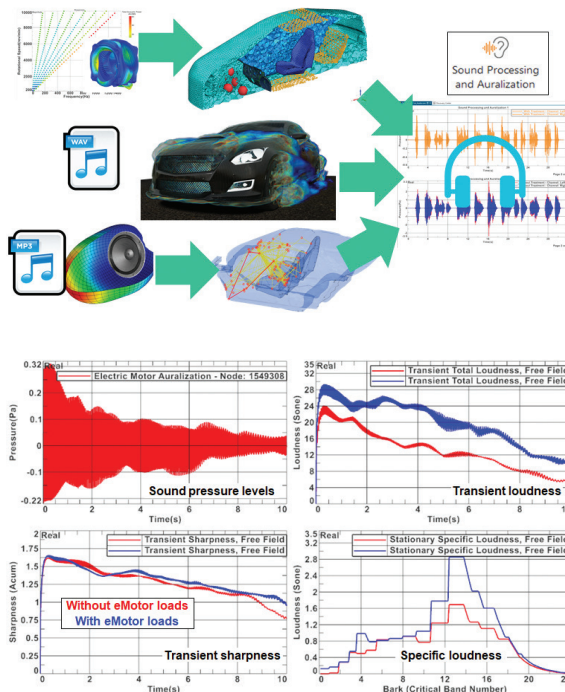

Module benefits

- Listen to your acoustic simulation models and experience the effect of design changes on the subjective perception of your product
- Assess your design in its intended user environment by creating complex listening scenarios
- Objectively evaluate acoustic performance with industry-standard sound quality metrics such as loudness and sharpness for sound quality evaluation

Key features

- Define acoustic sources based on
 - Time domain data (from wav/mp3 recordings or processed acoustic pressure simulation results)
 - Acoustic pressure order-cut simulation results and desired RPM profiles for rotating machinery
- Combine each source with the corresponding transfer function based on
 - Simulated ray acoustics impulse responses
 - Simulated transfer functions from Simcenter 3D Acoustics FEM or BEM models by processing the results inside Simcenter 3D
- Plot time data for complex scenarios and listen to the resulting soundscape
- Turn on/off or modify individual tracks to assess the impact on total sound perception
- Evaluate sound quality metrics (loudness and sharpness)

Capabilities chart

General capabilities	Specific capabilities							FEM acoustics			BEM acoustics							
		Simcenter 3D Meshing for Acoustics	Simcenter 3D Noise and Vibration Modeling *	Simcenter Nastran Basic **	Simcenter Nastran Dynamic Response *	Simcenter Nastran Advanced Dynamics bundle *	Simcenter Nastran Advanced Acoustics	Simcenter Nastran Acoustics Trim	Simcenter 3D Aero-Vibro-Acoustics	Simcenter 3D Environment for BEM Acoustics	Simcenter 3D Acoustics BEM solver	Simcenter 3D Acoustics BEMAO solver	Simcenter 3D Acoustics Time Domain BEM solver	Simcenter 3D ATV	Simcenter 3D Acoustics HPC	Simcenter 3D Ray Acoustics	Simcenter 3D Load Identification *	Simcenter 3D Acoustics Auralization
Meshing	Surface wrapper mesh for FEM and BEM acoustics	•																
	Convex surface mesher	•																
	2D mesh with thickness (volumize)	•																
	Hybrid meshing for acoustics (tetrahedron and hexahedron)	•																
	Automatic open duct mesh creation	•																
	Generate acoustic envelope from structural mesh	•																
	Cavity meshing	•																
	Coarsener/remesher	•																
	Hole filling	•																
	Rib removal	•																
Boundary condition	Acoustics loads: monopoles						•											
	Acoustics loads: point source with directionality															•		
	Acoustics loads: plane waves						•				•							
	Acoustics loads: panel normal velocity						•			•								
	Acoustics loads: panel source															•		
	Acoustics loads: dipoles, distributed plane waves, enforced acoustic pressure, radiating sources						•			•								
	Acoustics loads: noise source															•		
	Aero-acoustic loads: fan source, surface dipoles, quadrupoles								•									
	Turbulent boundary layer loads								•									
	Mapped force loads from flow induced loads		•								•							
	Duct modes						•											
	Transfer admittance to model perforated wall/sheet						•			•			•					
	Vibro-acoustic transfer admittance to model trim between structural plate and acoustic cavity							•										
	Acoustic absorber (impedance) boundary condition						•				•					•		
	Acoustic continuity to connect different domains						•											
Acoustic absorption, diffusion and transmission coefficients															•			

General capabilities	Specific capabilities	FEM acoustics														BEM acoustics			
		Simcenter 3D Meshing for Acoustics	Simcenter 3D Noise and Vibration Modeling *	Simcenter Nastran Basic **	Simcenter Nastran Dynamic Response *	Simcenter Nastran Advanced Dynamics bundle *	Simcenter Nastran Advanced Acoustics	Simcenter Nastran Acoustics Trim	Simcenter 3D Aero-Vibro-Acoustics	Simcenter 3D Environment for BEM Acoustics	Simcenter 3D Acoustics BEM solver	Simcenter 3D Acoustics BEMAO solver	Simcenter 3D Acoustics Time Domain BEM solver	Simcenter 3D ATV	Simcenter 3D Acoustics HPC	Simcenter 3D Ray Acoustics	Simcenter 3D Load Identification *	Simcenter 3D Acoustics Auralization	
Boundary condition (continued)	Infinite plane to represent reflective surfaces																		
	Anechoic nonreflective boundary (AML)																		
	Anechoic end duct																		
	Convective flow effects																		
Materials	Acoustic fluid																		
	Poro-elastic materials																		
	Porous materials - Craggs, Delany-Bazely-Miki and Jonhson-Champoux-Allard																		
	Temperature dependent fluid for modeling																		
	Temperature dependent fluid for solving																		
	Humidity dependent fluid																		
Representations	Mode set representation																		
	Mode set response																		
	FRF set representation																		
	FRF set response																		
	ATV set representation																		
	ATV set response in Simcenter Nastran																		
	VATV set representation																		
	VATV set response in Simcenter Nastran																		
Solution	ATV, VATV and MATV response in noise and vibration solver																		
	RDMODES (Recursive domain method for computing structural modes faster)																		
	Fully/weakly coupled vibro-acoustics with finite element																		
	Fully/weakly coupled vibro-acoustics with boundary element																		
	Finite element method acoustics (FEM Acoustics)																		
	Finite element method adaptive order acoustics (FEMAO Acoustics)																		
	Vibro-acoustic transfer admittance																		
	Boundary element method adaptive order acoustics (BEMAO Acoustics)																		
	Acoustics transfer vector analysis (FEM Acoustics, BEM Acoustics and Ray Acoustics)																		
	Vibro-acoustic transfer vector analysis (FEM Acoustics)																		
	Modal expansion																		
	Inverse numerical acoustics																		
Indirect/direct boundary element method acoustics (BEM Acoustics)																			

General capabilities	Specific capabilities	FEM acoustics			BEM acoustics				Simcenter 3D ATV	Simcenter 3D Acoustics HPC	Simcenter 3D Ray Acoustics	Simcenter 3D Load Identification *	Simcenter 3D Acoustics Auralization
		Simcenter 3D Meshing for Acoustics	Simcenter 3D Noise and Vibration Modeling *	Simcenter Nastran Basic **	Simcenter Nastran Dynamic Response *	Simcenter Nastran Advanced Dynamics bundle *	Simcenter Nastran Advanced Acoustics	Simcenter Nastran Acoustics Trim					
Solution (continued)	Transient boundary element method (Transient BEM) acoustics												
	Solving up to four parallel processes												
	Solving with more than four parallel processes												
Postprocessing	Pressure, acoustic velocity and intensity at microphone location and acoustic power												
	Contributions of structural modes, panel and grids on the total acoustic response												
	Directivity plots												
	Ray path analysis												
	Sound quality criteria												
	Contributions of individual sources to the total acoustic response												
	Listen to the resulting soundscape for time data												
	Sound quality metrics (loudness and sharpness)												

Legend:

If several • are present in a single row, interpret as "OR"
 If several cells are merged with one •, interpret as "AND"
 * = refer Simcenter 3D for structural dynamics
 ** = refer Simcenter 3D for structures

Note: Simcenter 3D Engineering Desktop is a minimum prerequisite for all Simcenter 3D products.
 Other dependency or prerequisites may apply for individual products.

Siemens Digital Industries Software
siemens.com/software

Americas
 1 800 498 5351

Europe
 00 800 70002222

Asia-Pacific
 001 800 03061910

For additional numbers, click [here](#).

© 2024 Siemens. A list of relevant Siemens trademarks can be found [here](#). Other trademarks belong to their respective owners.