



DIGITAL INDUSTRIES SOFTWARE

# Simcenter 3D for structural simulation

Increasing realism and improving insight

## Solution benefits

Reduce risk and cost while developing innovative structures

Investigate product performance virtually in all possible operating conditions, including thermally influenced operating conditions

Obtain more accurate solution results than linear analysis when standard linear assumptions are not valid

Improve confidence in final designs by virtually investigating your product's performance in all possible operating conditions

**Simcenter™ 3D software for structural simulation offers a set of finite element (FE) structural solvers that are part of the Simcenter portfolio of simulation tools. They are used by engineers across industries as part of their product development process to evaluate the structural performance of their systems.**

## Providing finite element solution for experienced CAE analysts

Simcenter 3D for structures is powered by the well known Simcenter Nastran® software.

Structural solutions of Simcenter 3D offer scalable, open and extensible capabilities for both general and advanced analysts. They can be used on

laptop, workstation and servers to solve everything from small models to the largest state-of-the-art industrial models.

Simcenter Nastran is available with enterprise licensing, which means it can be used independently from Simcenter pre/post solutions and can run on Windows and Linux operating systems.

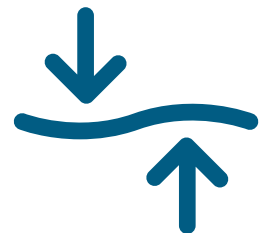

Structures

SIEMENS

[siemens.com/simcenter3d](https://www.siemens.com/simcenter3d)

# Simcenter 3D for structural simulation

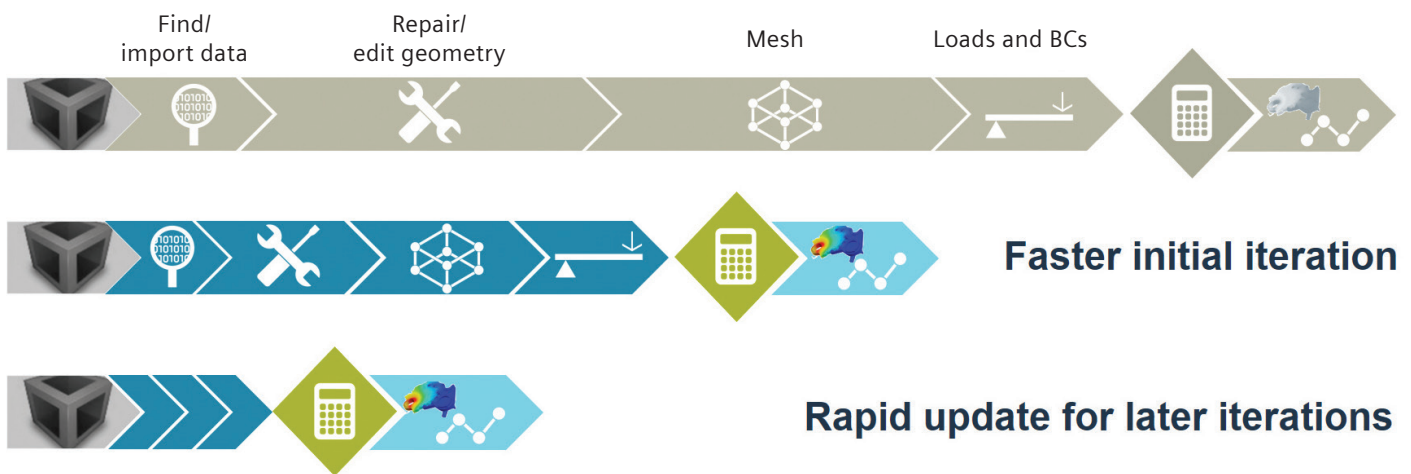

## Reduce risk by using simulation to save time and cost

Simcenter 3D software addresses complex product engineering by delivering significant improvements in simulation efficiency. With advanced-capability 3D simulation technologies and powerful model preparation technology, Simcenter 3D offers new methods that increase realism and deliver better insight.

## Accelerate innovation with rapid iterations

Synchronous technology in Simcenter 3D helps you reduce the time spent on model abstraction and geometry editing. Meshes, loads and boundary conditions are all associated with the base design, so when the design topology changes, you can rapidly update your simulation results. The solvers and analysis tools provide all the accuracy and speed you need for timely simulation-driven insights.

## Investigate product performance virtually under all possible operating conditions

Simcenter 3D includes solvers that enable you to dive deep into the physics. Every application specialist will find state-of-the-art technology that fits the problem – static or dynamic, linear or nonlinear, composite or other, including temperature-dependant materials and thermal loads acting on a structure.

## Co-simulation with Simcenter Nastran

Beyond structural solutions, Simcenter Nastran also enables co-simulation of structural, thermal and flow physics. A dedicated multiphysics environment allows you to define the complete solution on a single model, making co-simulation easily accessible to a broad set of users.

## A platform for multidiscipline simulation

The Simcenter 3D structural simulation solution is part of a larger, integrated multidiscipline simulation environment with the Simcenter 3D Engineering Desktop at the core for centralized pre-/postprocessing for all Simcenter 3D solutions. This integrated environment helps you to achieve faster CAE processes and streamline multidiscipline simulations that integrate structural simulation with other disciplines like thermal simulation, fluid dynamics, multibody dynamics, or electromagnetics simulation.

## Industry applications

Simcenter Nastran has helped manufacturers as well as engineering suppliers in many industries with their critical engineering computing needs so they can produce safe, reliable and optimized designs within increasingly shorter design cycles.

## Aerospace and defense

Utilizing Simcenter 3D gives aerospace engineers a comprehensive toolkit for various applications. When analyzing the airplane frame, tools are available to assess stiffness, frame durability, and modal frequency, ensuring structural integrity and performance. When analyzing the wings, simulation can measure stiffness, skin buckling resistance, and modal frequency to maintain aerodynamic efficiency and safety. The airplane hatch's seals and structural strength are meticulously examined to prevent failures that could jeopardize the aircraft's integrity.

For the airplane's control surfaces and support structures, pylons, ailerons, and stabilizers can be evaluated for stiffness and overall strength, safeguarding against the intense forces encountered during flight.

For spacecraft, Simcenter 3D provides capabilities for analyzing thermal stress and distortion, using composites, and modal frequencies, essential for ensuring durability and reliability in the harsh conditions of space.

Simulation of aero engines offers insights into rotating loads, distortion, including for a choice of materials like composites, and detailed analyses of compressor and turbine components. These evaluations include thermal stress, lifing, bolt stresses, and distinct considerations like cyclic symmetry, axisymmetry, and, in the case of turbines, creep and break-out modeling.

Launch vehicles and their structures also benefit from simulation, with tools to assess thermal stress, maneuver and payload bracket loads, as well as the effects of wind and launch loads, critical for successful missions.

Finally, the casing of aero engines, vital for enclosing and protecting critical components, can be thoroughly assessed for its ability to withstand bearing and maneuver loads.

## Automotive – Ground vehicles

Simcenter 3D offers automotive simulation engineers a comprehensive suite of tools geared toward enhancing vehicle design and performance. The software enables detailed analysis of the vehicle body, including assessments of roof crush resistance, panel strength, stiffness, and frame durability. For powertrain and driveline components, it provides insights into managing torque loads and mitigating thermal stress and distortion. The chassis functionality allows for the examination of harshness loads and suspension deflections, crucial for optimizing ride quality.

Moreover, it caters specifically to the needs of off-highway vehicles by evaluating strength, durability, rollover protective structures (ROPS), and overall stability. Manufacturing tools within the suite aid in predicting and preventing defects by analyzing thermal stress, modal frequency, and bolted stresses. Lastly, it includes features for assessing the stability and stress resistance of support structures, ensuring they meet rigorous demands. Simcenter 3D streamlines the process of creating safer, more efficient vehicles through its versatile and robust toolset.

## Marine

Simcenter 3D offers marine engineers specialized tools for evaluating ship integrity and performance, including analyses of stiffness, deformation, and strength for entire ships, as well as detailed inspections of hull skin rupture risks and bulkhead structural strength. This ensures vessels meet maritime standards, maintaining safety and integrity.

## Electronics

Using Simcenter 3D, electronics simulation engineers have tools to ensure the durability and reliability of their designs. This includes drop simulations and stress analysis for hand-held devices, thermal stress, and distortion checks for printed circuit boards (PCBs). For electronic boxes, engineers can evaluate bracket strength and analyze modal frequencies, enhancing the product's structural integrity and performance.

## Consumer goods

Using Simcenter 3D, a consumer goods simulation engineer can extensively evaluate packaging, focusing on its strength, stability, hyperelasticity, and creep. This ensures durability and performance under different conditions.

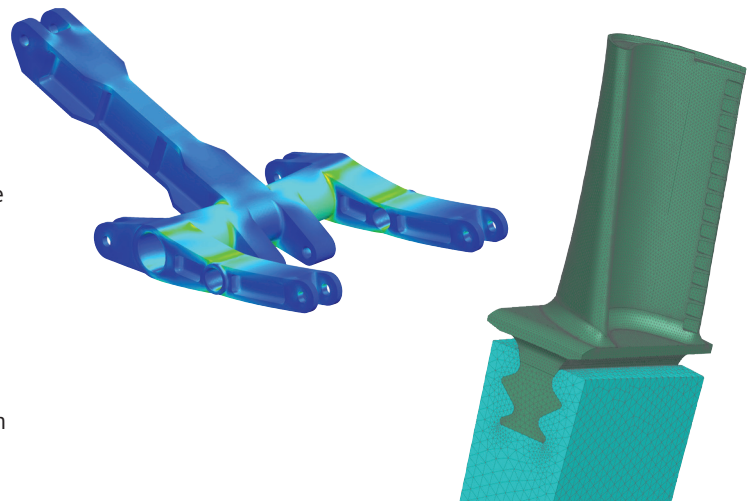

# Simcenter 3D Structures

Simcenter 3D Structures software is a unified, scalable, open and extensible 3D computer-aided engineering (CAE) environment for simulation analysts. Simcenter 3D Structures is a bundle combining the Simcenter 3D Engineering Desktop, Simcenter Nastran environment and the Simcenter Nastran Basic solver. Together, Simcenter 3D Structures gives you best-in-class simulation modeling with the power to perform basic structural analysis with an industry-standard solver. The Simcenter 3D Engineering Desktop contained in Simcenter 3D Structures speeds the simulation process by helping you efficiently build the simulation model you need from 3D geometry faster than traditional CAE preprocessors. The integrated Simcenter Nastran solver in Simcenter 3D Structures lets you seamlessly submit analysis models for linear statics, normal modes, buckling and basic heat transfer analyses. Simcenter 3D Structures also forms the foundation on which you can add additional solutions for structural dynamics, multistep nonlinear, thermal, flow, acoustics, motion, optimization and multiphysics analyses, all from a single environment.

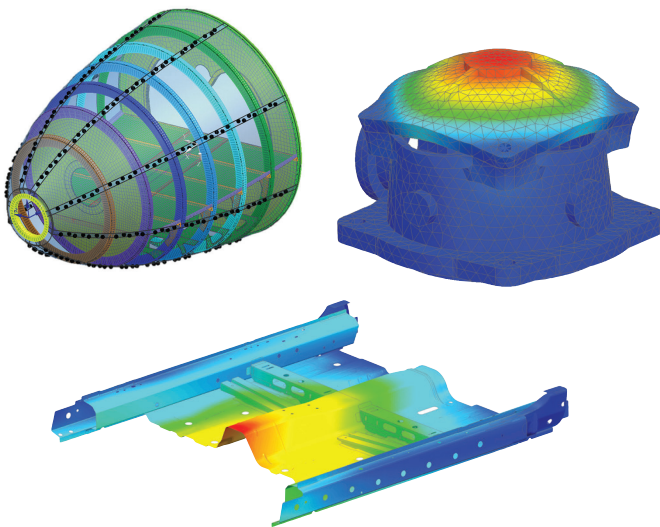

## Module benefits

- Speed simulation processes by up to 70 percent
- Perform accurate, reliable structural analysis with the integrated Simcenter Nastran Basic solver
- Increase product quality by rapidly simulating design tradeoff studies
- Lower overall product development costs by reducing costly, late design change orders
- Efficiently manage large, complex analysis models
- Capture and automate best practices and commonly used processes
- Easily add multidiscipline simulation capabilities as your analysis needs grow

## Key features

- All-inclusive software package with Simcenter 3D Engineering Desktop for pre/post together with Simcenter Nastran Basic for structural analysis
- NX is a leading geometry kernel which is used as part of Simcenter 3D to provide rapid geometry editing and abstraction
- Comprehensive meshing tools combined with efficient FE assembly management
- Immerses engineers in the Simcenter Nastran environment by using familiar terminology and extensive support of product-specific elements and entities
- Simulate structural analysis for linear statics, normal modes, buckling and heat transfer using the trusted Simcenter Nastran solver

# Simcenter Nastran

Simcenter Nastran allows you to initiate digital simulation into your product development process by providing access to a broad library of finite element types and material models, robustly manipulating load cases and delivering several efficient solution sequences for analyses on models of unlimited size. You can also perform sensitivity studies based on these analysis types.

The Simcenter Nastran basic license comes with a full base set of structural capabilities as the entry point for Simcenter Nastran. It also comes with a basic heat transfer solver and the resulting temperatures can be used as loads in a structural solution.



## Module benefits

- Reduce risk by using simulation to save time and cost compared to physical test cycles
- Accelerate innovation with rapid iteration and numerous what-if studies
- Investigate product performance virtually under all possible operating conditions, including thermally influenced operating conditions

## Key features

- Linear statics, normal modes, buckling
- Design sensitivity
- Basic nonlinear
- Composites
- Shared memory parallel (SMP) processing

Beyond the base set of capabilities, users can add more advanced structural capabilities including:

- Multistep nonlinear (static, transient)
- Distributed memory parallel (DMP) processing
- Linear dynamics (transient, frequency, random)
- Rotor dynamics
- Design and topology optimization
- Aeroelastic
- Vibroacoustic

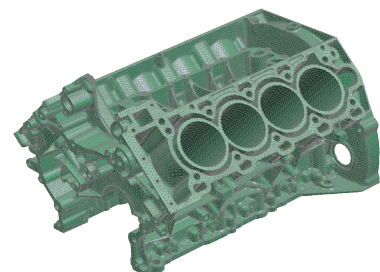
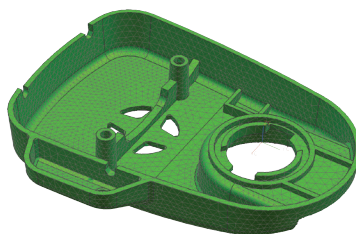
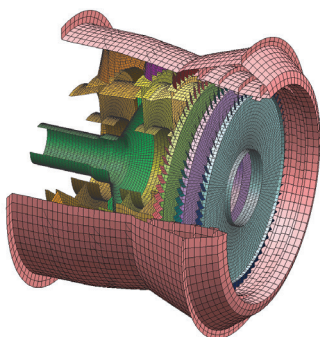

# Simcenter Nastran Multistep Nonlinear

Simcenter Nastran Multistep Nonlinear is an advanced solution that provides comprehensive capabilities for geometric nonlinear, contact, plasticity, creep, hyperelasticity and other material behaviors. The multistep solution allows users to set up sequential subcases for preload, nonlinear statics, nonlinear transient, modal, buckling, post buckling, harmonic modes and frequency response.

This is an add-on product to a basic license that provides two nonlinear solution options: Simcenter Nastran solution SOL 401 and SOL 402. Both are suited to a similarly wide range of nonlinear problems, but each also has unique features.

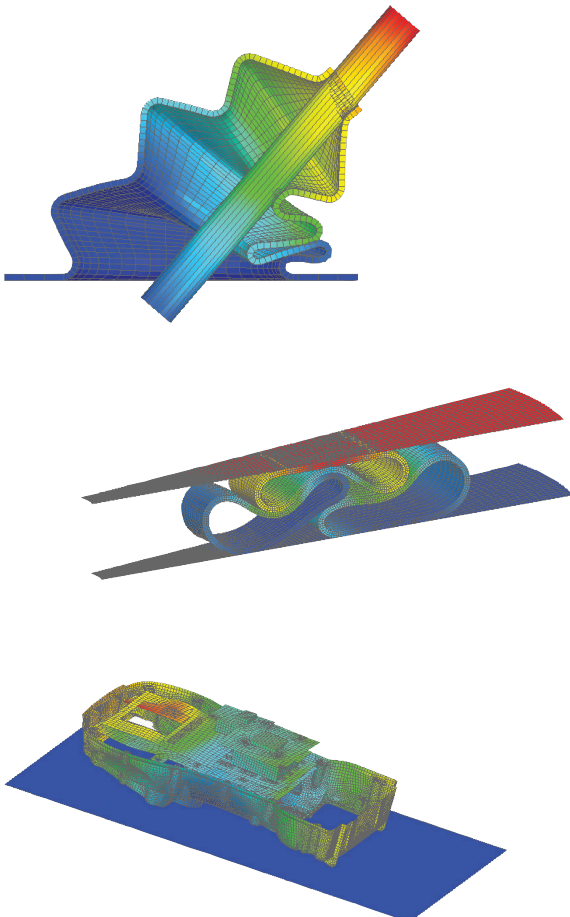

## Module benefits

- Use the same models already built and analyzed linearly with Simcenter Nastran Basic
- Improve confidence in final designs by virtually investigating your product's performance under all possible operating conditions
- Obtain more accurate solution results than linear analysis when standard linear assumptions are not valid

## Key features

- Static/dynamic analysis of models, including material and geometrical nonlinear behaviors
- Multistep solver allowing the following analysis types in different steps: static, dynamic, preload, modal, buckling, cyclic symmetry modes, Fourier harmonic modes
- Material nonlinear: hyperelasticity models (Mooney-Rivlin, Ogden, hyperfoam, Mullins effect, damping with Prony series), elastoplastic (Von Mises yield criterion, isotropic hardening, kinematic hardening, mixed hardening), thermal elastoplastic, creep, combined creep and elastoplastic
- Geometrical nonlinear: Large deformations, large strain, snap-through analysis (post buckling), follower forces
- Contact: Shell and solid element face contact, edge contact for axisymmetric modeling, single- and double-sided contact, self-contact, multiple friction models, tied contact, contact surface offsets, gap elements, contact activation/deactivation per subcase, contact pressures and force results, contact separation and sliding results

# Simcenter Nastran DMP

Simcenter Nastran DMP is an add-on module to Simcenter Nastran Basic. It enables parallel processing using distributed memory. It is an efficient approach to solving large models and can be used on workstations with multiprocessors using Windows. DMP solutions are available for static solves (SOL 101), modal eigenvalue solves (SOL 103), modal dynamic response solves (SOL 111 and 112), direct frequency solves (SOL 108) and nonlinear solves (SOL 401 and SOL 402). DMP can also be used in combination with SMP, which comes as part of Simcenter Nastran Basic.

**Module benefits**

- More cores provide faster solutions
- Allows solving large models that are not possible to solve on a single central processing unit (CPU)

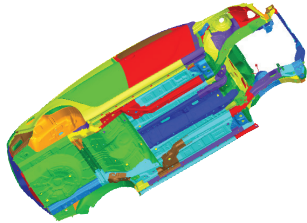
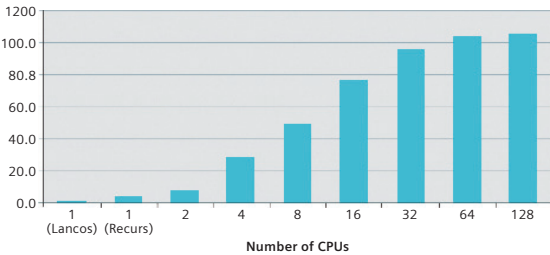
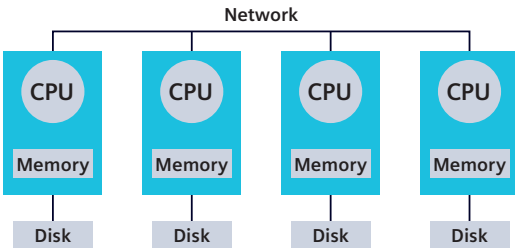

# Capabilities chart

General capabilities	Specific capabilities	Simcenter 3D Structures	Simcenter Nastran Basic	
Linear structural solutions	Statics	•	•	
	Dynamics (see Simcenter 3D for structural dynamics for details)			
	Normal modes	•	•	
	Buckling	•	•	
	Restarts	•	•	
	Parallel memory processing	•	•	
	<b>Elements</b>			
	3D solids	•	•	
	2D solids	•	•	
	Shell	•	•	
	Membrane	•	•	
	Beam	•	•	
	Springs	•	•	
	Rods	•	•	
	Rigid	•	•	
	<b>Composites</b>			
	Short fiber	•	•	
	Long fiber	•	•	
	<b>Connections</b>			
	Bolt preloads	•	•	
	Contact connections	•	•	
	Glue connections	•	•	
	<b>Materials</b>			
	Isotropic	•	•	
	Orthotropic	•	•	
	Anisotropic	•	•	
	Temperature dependence	•	•	
	<b>Loads/boundary conditions</b>			
	Gravity	•	•	
	Force/moment	•	•	
Pressure	•	•		
Rotational	•	•		
Temperature	•	•		
Enforced motion	•	•		

General capabilities	Specific capabilities	Simcenter 3D Structures	Simcenter Nastran Basic	Simcenter Nastran Multistep Nonlinear	
Nonlinear structural solutions	Large displacement effect			•	
	Large strain effect			•	
	Contact	•	•	•	
	– Coulomb friction	•	•	•	
	– Other friction models			•	
	<b>Nonlinear materials</b>				
	Plasticity			•	
	– Temperature dependence			•	
	– Bilinear			•	
	– Multilinear			•	
	– Isotropic hardening			•	
	– Kinematic hardening			•	
	Creep			•	
	Hyperelastic material			•	
	Nonlinear elastic material			•	
	Gasket material			•	
	User defined material			•	
	<b>Composite</b>				
	Cohesive delamination			•	
	Progressive failure			•	
	<b>Algorithms</b>				
	Static nonlinear			•	
	Transient nonlinear			•	
	Thermal mechanical co-simulation			•	
	Fluid-structural co-simulation			•	
	Modal about nonlinear state			•	
	Complex modal about nonlinear state			•	
	Buckling about nonlinear state			•	
	Multistep			•	
	Arc-length			•	
Cyclic symmetry modes			•		
Multi-harmonic modes			•		
Restart			•		
Element add/remove			•		

General capabilities	Specific capabilities	Simcenter 3D Structures	Simcenter Nastran Basic	Simcenter Nastran Multistep Nonlinear
Nonlinear structural solutions <i>(continued)</i>	Loads/boundary conditions (for nonlinear analyses only)			
	Distributed force			•
	Fluid pressure penetration			•
	Initial stress/strain			•
	Geometry imperfections			•

**Legend:**

• = included in module

Note: Simcenter Nastran Multistep Nonlinear is an add-on module to either Simcenter 3D Structures or Simcenter Nastran Basic.

**Siemens Digital Industries Software**  
**siemens.com/software**

Americas  
 1 800 498 5351

Europe  
 00 800 70002222

Asia-Pacific  
 001 800 03061910

For additional numbers, click [here](#).

© 2025 Siemens. A list of relevant Siemens trademarks can be found [here](#). Other trademarks belong to their respective owners.