

## DIGITAL INDUSTRIES SOFTWARE

# Simcenter 3D for structural dynamics simulation

Providing rapid insight into the dynamic response of structural systems

### Solution benefits

Perform comprehensive dynamic analysis and accelerate product time-to-market

Improve confidence in design by using Simcenter Nastran to investigate the product's performance under dynamic operating conditions

Get insight and improve NVH performance by dedicated tool set for NVH postprocessing and troubleshooting

Combine FE with measured data as loading or component's description for more realistic simulations and hybrid assemblies

Rapidly evaluate and improve the dynamic performance of rotating systems

Improve accuracy and increase confidence in your FE models by correlating with actual measured data

**Simcenter™ 3D software offers a comprehensive solution to understand, analyze and improve the response when a system is subjected to dynamic loading. This includes the industry standard Simcenter Nastran® software for dynamic analysis as well as interactive solutions for general dynamic analysis in order to efficiently understand and avoid excessive vibrations and stresses. Moreover, dedicated capabilities are available for noise, vibration and harshness (NVH) engineering, rotor dynamics and correlation.**

### Advancing structural dynamics prediction

Starting from the product concept phase, analysts and specialists can rely on

Simcenter 3D structural dynamics solutions to analyze design decisions and systematically improve dynamic characteristics of the system. The graphical user interface (GUI) of Simcenter 3D is fully customizable to suit your dynamic analysis processes by creating predefined templates and streamlining the product engineering process.

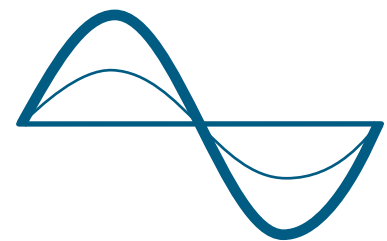





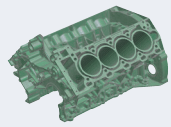
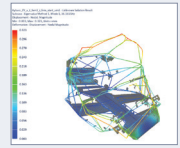

Dynamics

**SIEMENS**

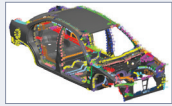
[siemens.com/simcenter3d](https://www.siemens.com/simcenter3d)

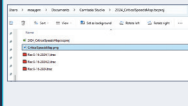
# Simcenter 3D for structural dynamics simulation

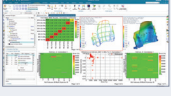
Preprocessing	Correlation and model update	Multilevel assembly	Connections modeling	Cavity mesh	Loads	Solution	Postprocessing														
<p>Defeaturing, synchronous technology, convergent modeling, multi-CAD support, component meshing, boundary conditions</p> 	<p>Pretest sensor and exciter placement, Modal Correlation (MAC, CoMAC, X-Orthogonality), FRF Correlation (FRAC), Sensitivity-based Model Updating, Simcenter Testlab interfaces</p> 	<p>Component models sub-assembly, hybrid modeling with test modes and FRFs, automatic assembly label resolution</p> 	<p>Universal connections, automated weld, joints, spring, damper bolt, and sealing identification</p> 	<p>Solid to shell meshing, surface wrap, polygon body</p> 	<p>Loads from measured data, dynamic loads from Simcenter 3D motion, mapped dynamic loads electro-magnetics, enforced vibration loads</p> 	<p>Model reduction techniques -modal, super-elements, FRFs</p>  <table border="1"> <caption>Solution Time vs Number of Processors</caption> <thead> <tr> <th>Number of Processors</th> <th>Minutes</th> </tr> </thead> <tbody> <tr> <td>4</td> <td>~350</td> </tr> <tr> <td>16</td> <td>~200</td> </tr> <tr> <td>32</td> <td>~150</td> </tr> <tr> <td>64</td> <td>~100</td> </tr> <tr> <td>128</td> <td>~75</td> </tr> <tr> <td>512</td> <td>~50</td> </tr> </tbody> </table>	Number of Processors	Minutes	4	~350	16	~200	32	~150	64	~100	128	~75	512	~50	<p>Modal, grid path, panel and structural model contribution, energy contributions, radiated power</p> 
Number of Processors	Minutes																				
4	~350																				
16	~200																				
32	~150																				
64	~100																				
128	~75																				
512	~50																				

What-if, optimization, feedback to designer

## NVH and rotor dynamics

Dedicated interactive and solver solutions are available to support industry workflows for NVH and the dynamics of rotating machinery.

## Uniquely combine real-world test data in the simulation

Using Simcenter 3D for structural dynamics solutions enables you to implement a distinctive hybrid simulation approach to leverage measured data as a component representation in a system-level finite element (FE) model, or to apply real-life loading to accurately and robustly accelerate the engineering process.

## Increasing confidence in dynamic FE models

An integral part of making product engineering decisions is having confidence in the simulation models so you can accurately predict reality. Correlation solutions allow you to validate and improve the dynamic behavior of simulation models from physical test data.

## Providing a platform for multidiscipline simulation

The Simcenter 3D structural dynamics solution is part of a larger, integrated multidiscipline simulation environment with the Simcenter 3D Engineering Desktop at the core for centralized pre-/postprocessing for all Simcenter 3D solutions. This integrated environment helps you to achieve faster CAE processes and streamline multidiscipline simulations that integrate dynamics and other disciplines like computing dynamic loads from motion, flow or electromagnetics solution.

### Industry applications

Since most systems are subjected to loading that is dynamic in nature at some point in the lifecycle, understanding the dynamic behavior of structures is an important topic in many fields. Simcenter 3D provides a complete solution to predict dynamic behavior, be it for a component, subsystem or the complete system.

#### Automotive and transportation

NVH performance strongly impacts the driving experience and perception of quality. Simcenter 3D offers integrated tools and solvers to predict NVH characteristics and analyze the root cause of noise and vibration problems.

#### Aerospace and defense

Simcenter 3D helps you identify the structural weaknesses of a given design and optimize the vibration and dynamic performance of aeronautical structures subjected to dynamic loading. Dedicated solutions for rotor dynamics help you assess the performance of aero-engines to avoid instabilities.

#### Industrial machinery

Machines that excessively vibrate during operation directly impact the quality of the manufactured product. Simcenter 3D delivers insights into the possible cause of machine vibrations, including rotating machinery.

#### Electronics and consumer goods

Simcenter 3D helps predict the dynamic characteristics of electronics and consumer goods to avoid excessive vibrations and stresses, which could result in fatigue or catastrophic failure.

#### Marine

With an increasing demand for faster and lightweight ships, design engineers can rely on Simcenter 3D to predict the response of the overall structure and its individual components that are subjected to wave and current actions.

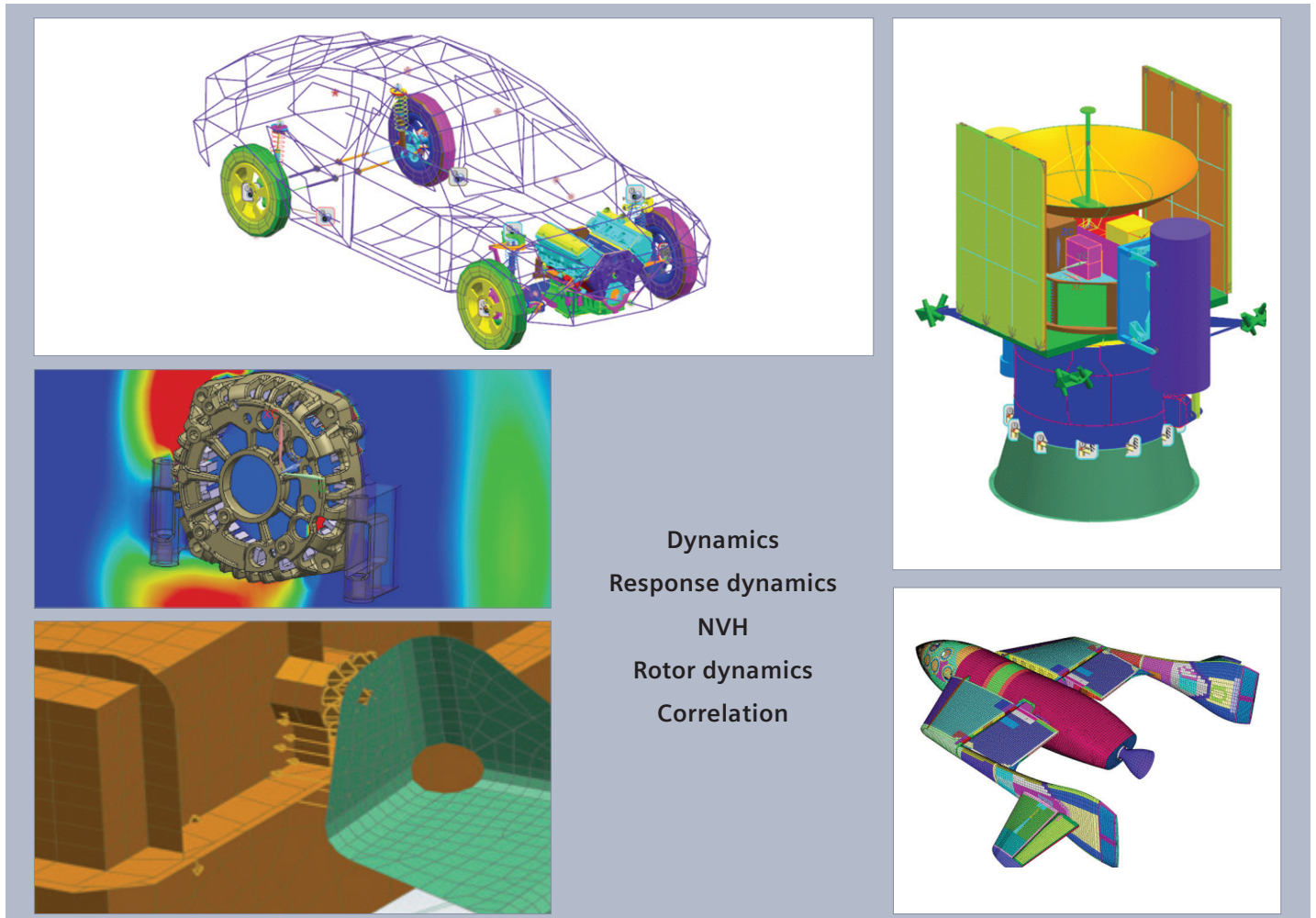

# Simcenter 3D

## Response Dynamics

Simcenter 3D Response Dynamics software is an integrated solution that makes dynamic analysis more accessible and efficient for the analyst. It allows you to predict the forced response of structural systems under various loading conditions in a single graphical user environment, thereby eliminating the complexity of setting up and launching analysis and providing rapid insight into dynamic behavior. Analysis information can then be used to perform design studies to enhance the new product development process and confirm the quality of designs prior to physical prototyping and production.

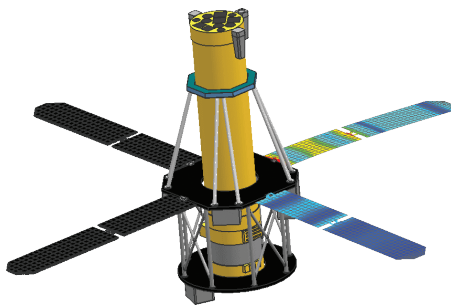
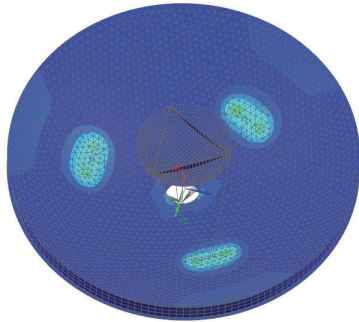

### Module benefits

- Gain rapid insight into the dynamic response of structural systems
- Quickly generate and view results graphically
- Leverage all capabilities of Simcenter 3D to make quick design changes and provide rapid feedback on dynamic performance

### Key features

- Predict modal response for transient, frequency (harmonic), random vibrations, shock spectrum, dynamic design analysis method (DDAM )(ship's shock loads) and quasi-static loads
- Efficiently calculate responses using a modal formulation starting from a priori solved set of Simcenter Nastran mode shapes
- Import, generate and edit the excitation information from computer-aided engineering (CAE) analysis and test data, including force, enforced motion and distributed loads (for example, dynamic pressure)
- Seamlessly interface analytical models with measured test data for instance-measured accelerations used for base-excitation loading
- Best-in-class random and sine base excitation events that handle real-world models with unparalleled performance and accuracy

# Simcenter 3D

## Noise and Vibration Modeling

Simcenter 3D Noise and Vibration Modeling offers a comprehensive set of noise and vibration pre/post capabilities addressing your need to build, understand, evaluate and optimize the noise and vibration performance of complete system and assembly models.

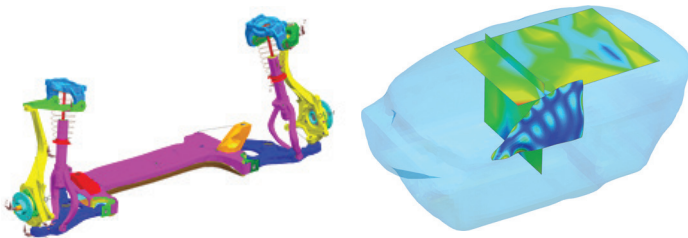
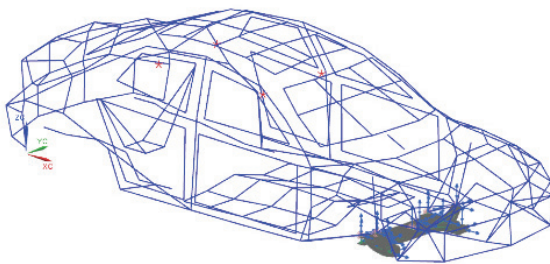
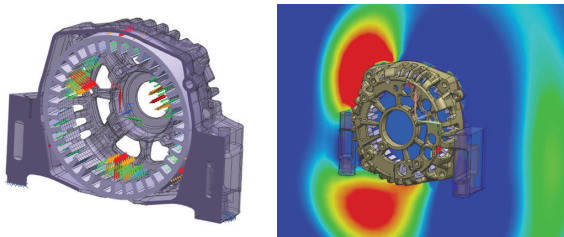

### Module benefits

- Gain valuable insight into the noise and vibration performance of your design
- Use data from measurements and previous simulations to create relevant load cases
- Use dynamically equivalent, reduced component representations in your assembly model to speed up response analysis

### Key features

- Intuitive noise and vibration diagnostics with support from modal, grid, panel, energy and path-contribution analysis
- Map test data and predecessor simulation data – multibody, electromagnetics (EM), computational fluid dynamics (CFD) – onto the vibro-acoustic simulation model, including time-to-frequency domain conversion for obtaining realistic loads
- Include frequency response function (FRF) and modal representations for structural components in assembly context using either simulation or test data
- Include acoustic transfer vectors (ATV) or vibroacoustic transfer vectors (VATV) representations for acoustic or vibro-acoustic components, which are re-usable for multi-load case scenarios for powertrain noise or cabin wind noise

# Simcenter 3D Load Identification

Operational loads or vibrations are very important for accurate response prediction but are often impossible or difficult to measure directly. Simcenter 3D Load Identification enables you to compute dynamics loadings of a structure for dynamics or acoustics. You can compute acoustic loads as well as structural loads.

Simcenter 3D Load Identification offers two ways of identifying the operational forces from measured data, either by a direct stiffness method or by an inverse matrix method. Using the direct stiffness approach, the relative displacement (or velocity or acceleration) from the input vibration data and input frequency response functions (FRFs) are used to compute the forces at node locations on your finite element model (FEM). The inverse matrix method allows you to compute an estimate of the operating loads, based on operational measurements, such as accelerations and measured FRFs.

Additionally, Simcenter 3D Load Identification can also be applied to acoustics applications. You can use a modal expansion solution to create enriched vibration results on a full FE model based on measured vibrations in only a few points. Or you can derive structural surface vibrations through inverse numerical acoustics, where measured pressure responses near the structure are used together with acoustic transfer vectors (ATVs) to identify the full surface vibrations. The obtained vibration field can then be used further for acoustic radiation analysis.

## Test



### Module benefits

- Determine operational forces or vibrations which is difficult or impossible to measure directly
- Determine acoustic volumetric source strength from acoustic pressure
- Get more realistic simulation by applying more accurate loading
- Combine measured loading data with FE simulations

### Key features

- Mount method to estimate mount forces by combining operational vibration data at each side of the mount and mount stiffness data
- Inverse matrix method by combination of operational measurements and transfer functions
- Based on all measured data or a combination of operation measurements and simulation data
- Straightforward application and reuse of the identified forces, vibrations and acoustic source strength to the simulation model

### Mount stiffness method

- Operational vibrations on both ends of the mounts are measured
- Mount stiffness FRFs measured in lab



$$F(\omega) = K(\omega)[X_s(\omega) - X_t(\omega)]$$

### Inverse matrix method

- Operational vibrations or acoustic pressures are measured
- FRFs measured in lab

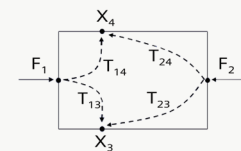

$$\begin{bmatrix} F_1 \\ F_2 \end{bmatrix} = \begin{bmatrix} T_{13} & T_{23} \\ T_{14} & T_{24} \end{bmatrix}^{-1} \begin{bmatrix} X_3 \\ X_4 \end{bmatrix}$$

# Simcenter 3D

## Noise and Vibration Response

The Simcenter 3D Noise and Vibration Response product provides users with the capability to perform modal-based forced response, FRF-based forced response and FRF synthesis to gain insight in the vibration or vibro-acoustic performance of a system. It is an alternative for users who have structural solvers from third party or for users who cannot subscribe to Simcenter Nastran.

For example, modal-based forced response is particularly useful in several scenarios that start from ANSYS or ABAQUS modes, or from measured modes. One can for example use the Simcenter 3D Noise and Vibration Forced Response product to compute surface vibration results which can subsequently be used in an analysis to predict acoustic radiation.

Another example is the embedded FRF-based forced response solver which provides a convenient and fast way to compute structural or vibro-acoustic response of a system that is described by simulated or measured FRFs under operational loading. This can be followed by TPA analysis using Simcenter 3D Noise & Vibration Modeling.

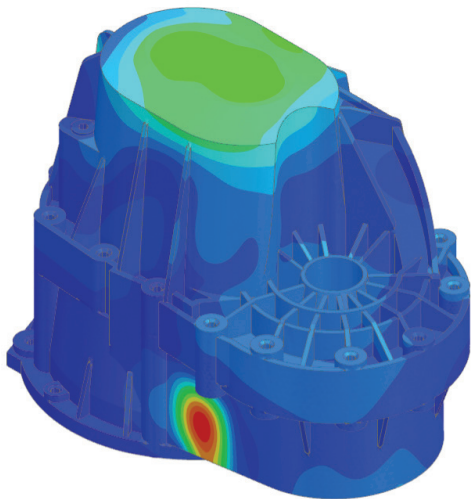

Gear box vibration response computed from Simcenter 3D Noise and Vibration Forced Response.

### Module benefits

- Dedicated modal- and FRF-based forced response solvers in support of NVH and Acoustics scenarios.
- Enabling users to perform forced response without access to a full structural solver such as Nastran
- Quickly compute FRFs from measured or simulated modes for use in NVH or as reduced FRF representation of a component in an assembly or for use in correlation

### Key features

- The FRF-based forced response solver provides a convenient and fast way to compute the structural or vibro-acoustic response of a system described by simulated or measured Frequency Response Functions (FRFs) under operational loading
- The Modal-based forced response solver provides a convenient way to compute the structural (vibration) response of a system described by a set of modes under operational loading
- The FRF Synthesis Solver allows to compute FRFs starting from a set of measured or simulated modes

# Simcenter 3D Assembly Composer

The Simcenter 3D Assembly Composer is a streamlined product to create system level FE models from system FE models.

It is a very practical tool for defining hybrid NVH models by combining FE subsystems with reduced (test/FE) components in the form of mode sets for instance. It can also be used as a streamlined solution to define full vehicle NVH models starting from subassembly models (BIW, door, suspension...).

The product offers an interactive network display to define the topology of the system level assembly by defining components, connectivity information and optionally lumped mass trim information. Once the assembly layout is defined, the AFEM assembly is automatically created in Simcenter 3D and syncs it with the network display of the Simcenter 3D Assembly Composer. All typical connections between full vehicle subsystems are available and the modeling is done for Simcenter Nastran.

## Module benefits

- Increase productivity and speed up system level (e.g. full vehicle NVH) creation time
- Decrease human error by capturing assembly topology in layout files
- Take out the complexity of full vehicle assembly model creation
- Rerun easily in case of component changes

## Key features

- Interactive network display to define full vehicle topology starting from subsystem FE models
- All typical full vehicle connections are supported (bolt, bushing, weatherstrip/sealing,...)
- Support of lumped mass trimming
- Automatic assembly from the defined full vehicle topology
- Integrated checking functionality
- Support of reduced subassembly representations (measured or FE), for instance by modal representation
- Automatic synchronization between Simcenter 3D NVH Composer and resulting Simcenter 3D assembly

# Simcenter 3D FE Model Correlation

Simcenter 3D FE Model Correlation software enables you to quantitatively and qualitatively compare simulation and test results, as well as two different simulations. It provides the tools needed to geometrically align the models, pair the shapes from both solutions, view mode and operational shapes and frequency response functions and calculate/display correlation metrics.

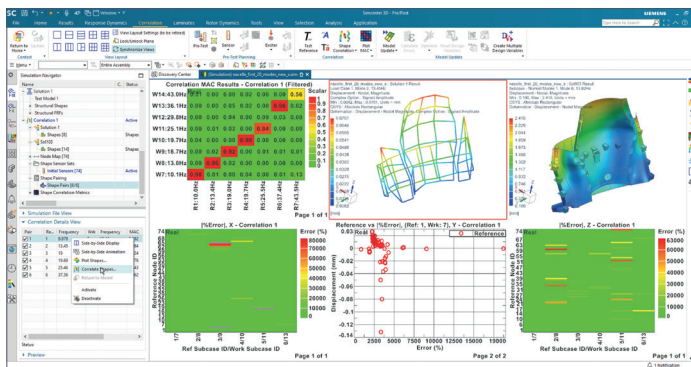

## Module benefits

- Validate the accuracy of the finite element model for structural, acoustic and vibro-acoustic dynamic analysis
- Determine sensor and exciter locations before performing physical modal tests
- Increase productivity by enabling model validation in the same environment as used for model creation and analysis

## Key features

- Supports Simcenter Nastran software, Abaqus, ANSYS and MSC Nastran results
- Test solution import using universal files or Simcenter Testlab™ software files
- Pretest planning including sensor and exciter placement, creation of automatic or manual visualization wireframes, as well as automatic face normal detection
- Intuitive and powerful test model alignment
- Shape correlation criteria: MAC, X-Orthogonality, frequency and error
- Modal, operational and static shapes
- Automatic and manual shape pairing
- Interactive matrix and mode-shape displays
- Frequency response function assurance criterion (FRAC)
- Interactive FRAC and FRF overlay plots
- Node mapping based on proximity, labels or names as well as manual methods

# Simcenter 3D FE Model Updating

Simcenter 3D FE Model Updating software is an advanced correlation tool designed to automatically update FE models to match real-life test data or other FE model results. The tool is fully integrated within Simcenter 3D Engineering Desktop, making the updating process efficient, intuitive and productive.

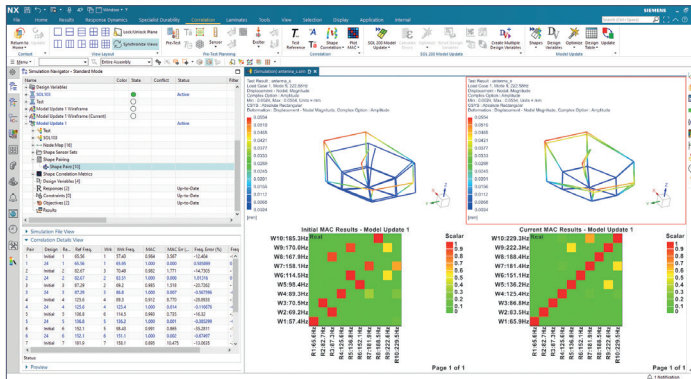

## Module benefits

- Improve accuracy and increase confidence in your FE models
- Increase productivity by performing model updating in the same environment used for model creation and analysis
- Provide quick sensitivity-based approach

## Key features

- Optimization targets: modal frequencies and mode shapes
- Mode shape correlation criteria: MAC, X-Ortho
- Automatic and manual mode pairing options
- Simultaneously update multiple configurations of the same FEM
- Automatic FEM update that can be easily cascaded to all simulations
- Automatic and manual design variable management
- Automatic generation of multiple design variables
- Support material and physical property design variables such as beam section areas, shell or laminate ply thickness and Young's modulus
- Simcenter Nastran or MSC Nastran SOL 200 licenses not required

# Simcenter 3D Rotor Modeling

Simcenter 3D Rotor Modeling is a comprehensive environment for pre- and postprocessing models used for rotor dynamics analysis using the Simcenter Nastran Rotor solver. Simcenter 3D Rotor Modeling guides you through the typical workflow of defining your rotors, bearings, and assemblies and then helps you set up the simulation solution parameters. Simcenter 3D Rotor Modeling also takes full advantage core Simcenter 3D Engineering Desktop capabilities to easily edit model geometry and keep your rotor simulation models in-synch with your design. The rotor modeling environment is where you also efficiently evaluate the results of your simulations visually and graphically so you can easily determine if your rotor designs are performing to your requirements.

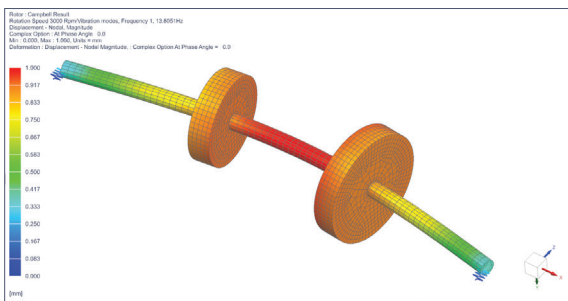
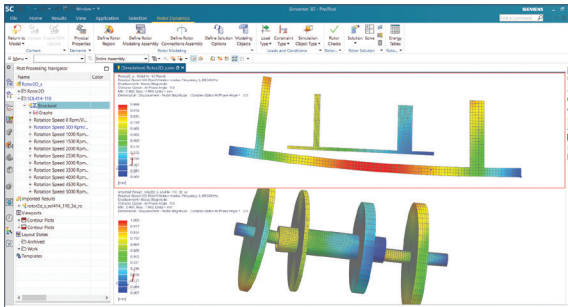

## Module benefits

- An integrated solution that helps you rapidly solve and iterate on your rotor designs to achieve optimal performance
- Understand how your rotor performs in unbalance analysis, predict a blade-out event, and determine critical speeds
- Guides you through a complete end-to-end workflow from rotor and bearing modeling, solution setup, and results visualization

## Key features

- Addresses a wide range of loading scenarios, like unbalanced loads, misalignment, time-dependent forces and more
- Efficient modeling techniques and model reduction like Fourier multi-harmonic elements or cyclic symmetry or superelement
- Wide range of post processing capabilities for Campbell diagram, energies distributions, modes and deformed shapes animations, orbit plots, recombination of results in 3D
- Model the rotors and stator parts of the assembly by different modeling approaches using efficient model reduction and connect the components by a collection of linking devices

# Simcenter Nastran Dynamic Response

Simcenter Nastran Dynamic Response software is the core solver for dynamic finite element analysis (FEA). It enables the Harmonic response analysis of a component or assembly subject to time- or frequency-varying excitations. Assessing dynamic response of a structure under different operating conditions is critical to industries such as automotive, aerospace, consumer products and other sectors that rely on electronic devices. It is possible to perform numerous what-if studies by virtually investigating the product's performance in various dynamic operating conditions by using the rich analysis tool set supported by Simcenter Nastran Dynamic Response.

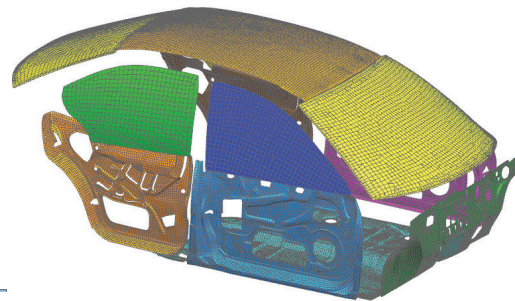
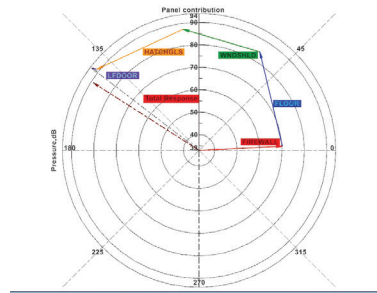
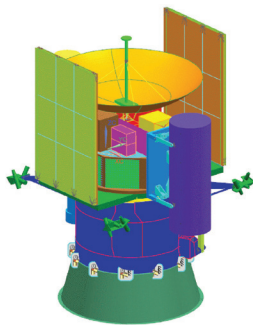
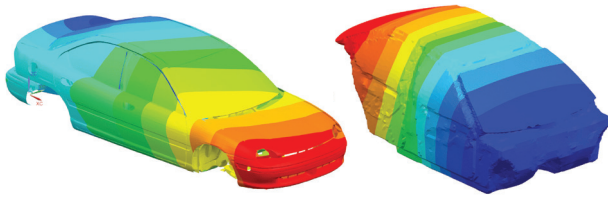

## Module benefits

- Assess dynamic performance of your physical model
- Apply to all applications, industries and model sizes
- Save time and cost compared to physical build-test-break cycles

## Key features

- Comprehensive dynamic response set. Supports frequency, transient and random response
- Includes a list of eigenvalue solvers such as Lanczos, Householder, Hessenberg, etc.
- Supports numerous types of dynamic loading in time and frequency domain
- Fast modal frequency response solvers (FFRS) applicable to large models and large number of modes - especially when the modes are coupled due to structural and viscous damping

# Simcenter Nastran Advanced Dynamics bundle

Simcenter Nastran Advanced Dynamics is a cost-effective bundle that provides a rich set of functionality for advanced dynamic analysis. It allows the user to produce reduced order models and use them in a system analysis. The reduced order model can be a modal model, an external superelement or an FRF representation. The advanced dynamic analysis product also features RDMODES, which is a fast eigenvalue solver for large models with many modes. Coupled with fast frequency response, large models with many modes and many frequencies can now be solved rather quickly. The advanced dynamics product also offers high performance computing (HPC) capability via distributed computing or DMP.

The advanced dynamics product also includes direct matrix abstraction program (DMAP). This product is the gateway to openness in Nastran. Users can alter the regular solutions and tailor it to meet their requirements.

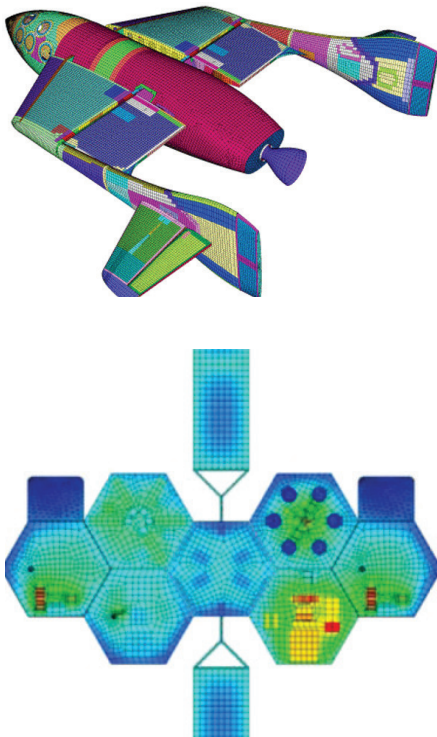

## Module benefits

- Use cost-effective bundle to perform comprehensive dynamic analysis and accelerate product time-to-market
- Build system assembly models using a hybrid assembly of components based on finite elements and test measurements or reduced order models

## Key features

- Includes all capabilities of Simcenter Nastran Dynamic Response
- Includes Nastran superelement representation and Simcenter Nastran FRF representation
- Computes the forced response of a product subject to time or frequency varying excitations
- Represents a component in the form of frequency response function, an alternate form of matrix representation of a component
- Large models consisting of large number of modes can be efficiently solved using recursive domain normal modes (RDMODES)
- Model slosh behavior - that is, predict slosh modes and hydro-elastic modes
- Analyze structural models in the presence of an airstream using aeroelastic analysis
- Modify and adapt out-of-the-box (OOTB) solution sequences using DMAP
- Perform advanced "Response Spectra" analysis
- Perform analysis with incompressible fluid in tanks and account for sloshing
- Perform DDAM analysis

# Simcenter Nastran DMP

Simcenter Nastran DMP facilitates a significant reduction in computing time by using multiple processors and computing resources. Simcenter Nastran DMP enables a higher level of parallelism and provides better scalability than shared memory processing (SMP).

## Module benefits

- Rapidly solve complex large problems
- Use the DMP solution to solve large problems significantly faster

## Key features

- Simcenter Nastran has many options for partitioning solution domains, such as geometric, frequency, hierarchic, load and RDMODES
- DMP can also be operated on a single node that has multiple processors
- Supported dynamic solution types are modal and direct frequency response, eigenvalue computation and modal transient

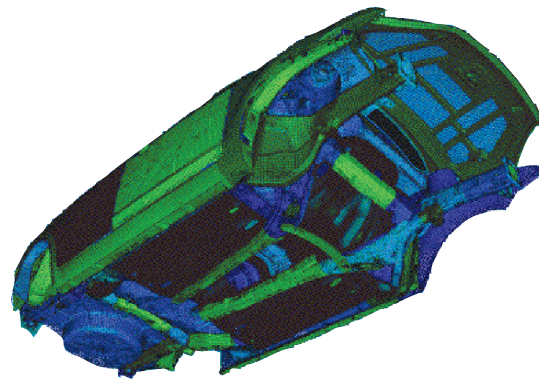
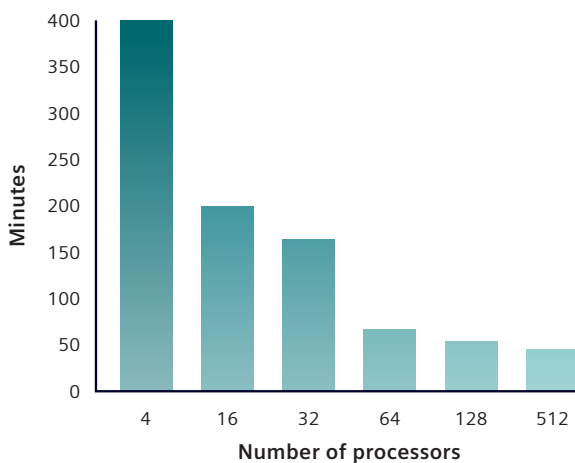

# Simcenter Nastran Rotor

Simcenter Nastran Rotor is the solver for simulating a variety of rotor dynamics analyses for mechanical engineers studying industrial rotating machinery applications, like gas turbines, pumps and more. Understanding critical operational speeds and predicting survivability of rotating systems is a critical, yet challenging task. Simcenter Nastran helps you determine these critical criteria by accounting for gyroscopic effects and centrifugal loads in a wide range of situations.

Pre- and postprocessing for Simcenter Nastran Rotor is done using the Simcenter 3D Rotor Modeling product.

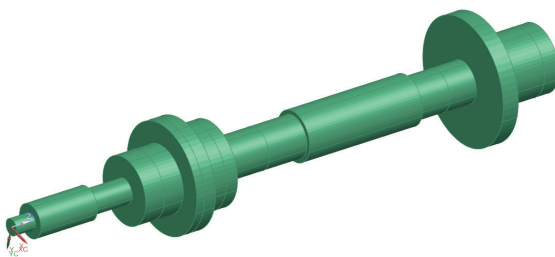
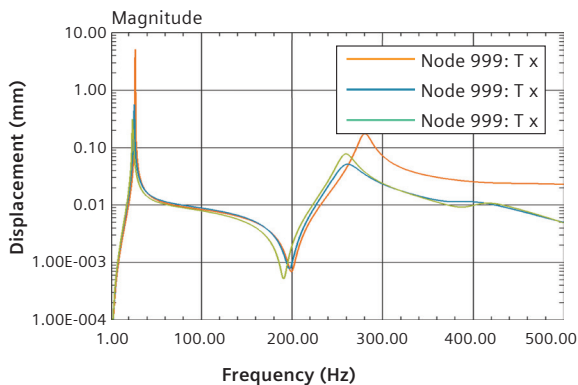

## Module benefits

- Simulate and assess rotor dynamics performance of your physical model
- Compute critical speeds and find whirl frequencies to avoid catastrophic failure of rotating machines

- Evaluate simple models with linear bearings to complex systems with nonlinear connections
- Breadth of analysis capabilities to cover a wide range of loading scenarios
- Reduce modeling time and speed solution time through modeling techniques like Fourier multiharmonic elements or cyclic symmetry or superelements
- Save time and cost compared to physical build-try break cycles

## Key features

- Compute Campbell diagram, with critical speeds, complex modes, and whirl frequencies
- Simulate using frequency-dependent (synchronous or asynchronous, modal or direct, one or multiple harmonics) or time-dependent excitation or maneuvers loads
- Account for geometric nonlinearities of connection elements in the simulation
- Supports typical rotor dynamics scenario like unbalance loading or blade out analysis or misalignment
- Account for geometric nonlinearities of connection elements in the simulation
- Analyze symmetric and asymmetric rotor models, as well as multiple rotors with different rotation speeds
- Include differential stiffness to compute centrifugal stiffening/softening effects
- Solve the model in the fixed or rotating coordinate reference system
- Enable SMP/DMP in combination with Simcenter Nastran DMP

# Capabilities chart

General capabilities	Specific capabilities	Simcenter 3D Response Dynamics	Simcenter 3D Noise and Vibration Modeling	Simcenter 3D Load Identification	Simcenter 3D Noise and Vibration Forced Response	Simcenter 3D Assembly Composer	Simcenter 3D FE Model Correlation	Simcenter 3D FE Model Updating	Simcenter 3D Rotor Modeling	Simcenter Nastran Dynamic Response	Simcenter Nastran Advanced Dynamics bundle	Simcenter Nastran DMP	Simcenter Nastran Rotor
		Structural dynamics											
Structural linear dynamics	Modal transient response	•								•	•		
	Modal frequency response	•			•					•	•		
	Direct transient response									•	•		
	Direct frequency response									•	•		
	Cyclic direct frequency response									•	•		
	Complex modal analysis									•	•		
	Shock spectrum	•								•	•		
	Random vibration	•								•	•		
	Dynamic design analysis method (DDAM)	•								•	•		
	FRF based forced response										•	•	
	Incompressible fluid effects and sloshing										•		
Advanced linear dynamic analysis	Superelements										•		
	Coupled fluid-structure (vibro-acoustic) analysis									•	•		
	Frequency transfer functions (FRF)				•						•		
	Recursive domain normal modes (RDMODES)										•		
	Fast frequency response (FASTFR)									•	•		
	Direct matrix abstraction programming (DMAP)										•		
	Aero-elasticity										•		
	Incompressible fluid effects and sloshing										•		
Parallel processing	Shared memory parallel (SMP)	•			•					•	•	•	
	Distributed memory parallel (DMP)										•	•	
	SMP/DMP for Rotor										•	•	
Noise and vibration (NVH)													
NVH model creation	2D full vehicle topology definition from subassemblies					•							
	Full vehicle assembly automation					•							
	Bolt					•							
	Spring and bushing					•							
	Weatherstrip/sealing					•							

General capabilities	Specific capabilities	Simcenter 3D Response Dynamics	Simcenter 3D Noise and Vibration Modeling	Simcenter 3D Load Identification	Simcenter 3D Noise and Vibration Forced Response	Simcenter 3D Assembly Composer	Simcenter 3D FE Model Correlation	Simcenter 3D FE Model Updating	Simcenter 3D Rotor Modeling	Simcenter Nastran Dynamic Response	Simcenter Nastran Advanced Dynamics bundle	Simcenter Nastran DMP	Simcenter Nastran Rotor
NVH model creation (continued)	Seam weld					•							
	Kinematic (e.g. latch and bumpstop)					•							
	Lumped mass trimming					•							
NVH post-processing	Modal contribution		•										
	Panel/grid contribution		•										
	Path contribution		•										
	Energy contribution		•										
<b>Noise and vibration (NVH) (continued)</b>													
System level NVH (hybrid)	Modal representations (modal coupling preprocessing)		•										
	FRF representations (FRF coupling preprocessing)		•										
	FRF analysis case		•										
Additional NVH	Transfer path analysis		•										
	Load identification analysis (mount method, inverse force)			•									
<b>Rotor dynamics</b>													
Rotor models	1D (line models), 3D models												•
	2D multi-harmonics models												•
	Mixed modeling representation												•
	Multiple rotors												•
	Cyclic symmetry												•
Super-elements	Superelement for the nonrotating and rotating parts												•
Bearing models	Springs, dampers, bushings, bearings												•
	Hydrodynamic, roller ball bearings, squeeze film dampers												•
	Nonlinear bushings and bushing with rupture law												•
	User proprietary bearings												•
Pre-processing	Rotor models preparation								•				
	Rotor Dynamic solution setup								•				
Rotor dynamic solutions	Campbell diagram and stability analysis												•
	Modal analysis (normal/complex)												•
	Harmonic response (direct/modal, synchronous/asynchronous, one or multiple frequencies)												•
	Linear/Nonlinear transient response												•
	Linear/Nonlinear static analysis												•

General capabilities	Specific capabilities	Simcenter 3D Response Dynamics	Simcenter 3D Noise and Vibration Modeling	Simcenter 3D Load Identification	Simcenter 3D Noise and Vibration Forced Response	Simcenter 3D Assembly Composer	Simcenter 3D FE Model Correlation	Simcenter 3D FE Model Updating	Simcenter 3D Rotor Modeling	Simcenter Nastran Dynamic Response	Simcenter Nastran Advanced Dynamics bundle	Simcenter Nastran DMP	Simcenter Nastran Rotor
Rotor dynamic solutions <i>(continued)</i>	Unbalance analysis												•
	Blade out analysis												•
	Misalignment analysis												•
	Thermal static bow												•
	Large rotation and large displacements												•
	Damping: viscous, structural, modal, hysteretic												•
	Rotating/fixed reference frame												•
Postprocessing <i>(continued)</i>	Campbell diagram, damping diagram, Nyquist diagrams								•				•
	Mode shapes visualisation and whirling animation								•				
	Recombine 3D results after 2D models analyses								•				•
	Recombine 3D results after cyclic symmetry computations								•				•
	Table of energies distribution								•				•
	Recover results after superelement computations								•				•
	Clearance consumption monitoring								•				•
<b>Correlation</b>													
Pretest and correlation	Pretest planning						•						
	Test model alignment and geometry mapping						•						
	Test-analysis, analysis-analysis correlation						•						
	Shape correlation: MAC, COMAC, error scatter, function and matrix						•						
	Modal correlation: X-orthogonality						•						
	Modal, operational, static structural shapes/acoustic mode shapes						•						
	FRF correlation: structural, acoustic and vibro-acoustic						•						
	Local coordinate systems						•						
	Shape pairing and visual comparison						•						
	Simcenter Testlab interface						•						
	Teamcenter interface						•						

General capabilities	Specific capabilities	Simcenter 3D Response Dynamics	Simcenter 3D Noise and Vibration Modeling	Simcenter 3D Load Identification	Simcenter 3D Noise and Vibration Forced Response	Simcenter 3D Assembly Composer	Simcenter 3D FE Model Correlation	Simcenter 3D FE Model Updating	Simcenter 3D Rotor Modeling	Simcenter Nastran Dynamic Response	Simcenter Nastran Advanced Dynamics bundle	Simcenter Nastran DMP	Simcenter Nastran Rotor
Model updating	Design variable definition							•					
	Dedicated DESOPT 200 - model update solution							•					
	Design variable sensitivities							•					
	Frequency, mode shape (MAC and X-orthogonality)							•					
	Embedded eigenvalue solver							•					
	Multiple optimization algorithms							•					
	FEM and SIM update							•					
	Model updating for Simcenter Nastran and MSC Nastran							•					
Simultaneous update of multiple configurations							•						

**Legend:**

• = included in module

Note: Simcenter 3D Engineering Desktop is a minimum prerequisite for all Simcenter 3D products. Other dependency or prerequisites may apply for individual products.

**Siemens Digital Industries Software**  
**siemens.com/software**

Americas  
 1 800 498 5351

Europe  
 00 800 70002222

Asia-Pacific  
 001 800 03061910

For additional numbers, click [here](#).

© 2025 Siemens. A list of relevant Siemens trademarks can be found [here](#). Other trademarks belong to their respective owners.