

DIGITAL INDUSTRIES SOFTWARE

Simcenter 3D

Solution guide

[siemens.com/simcenter3d](https://www.siemens.com/simcenter3d)

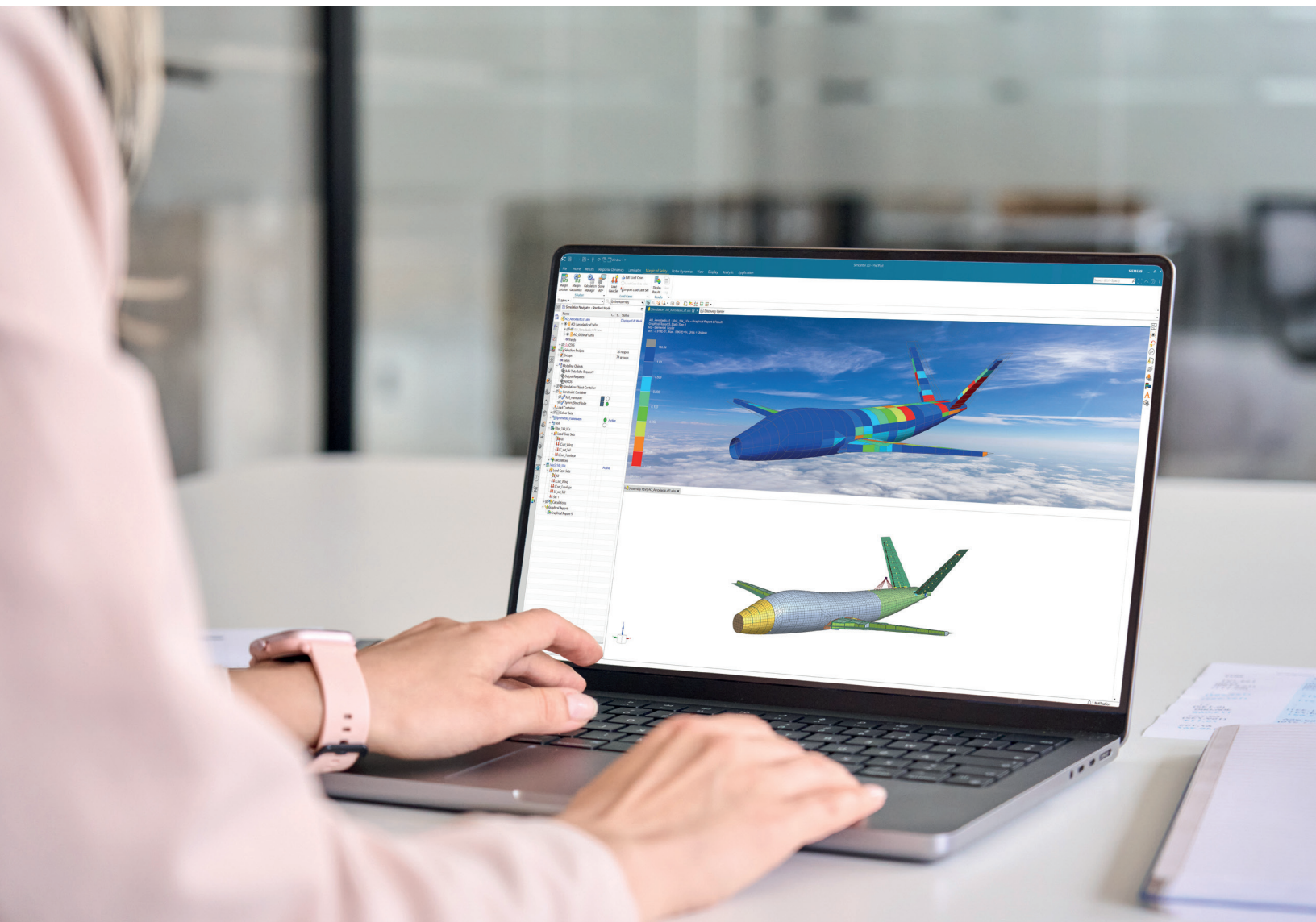

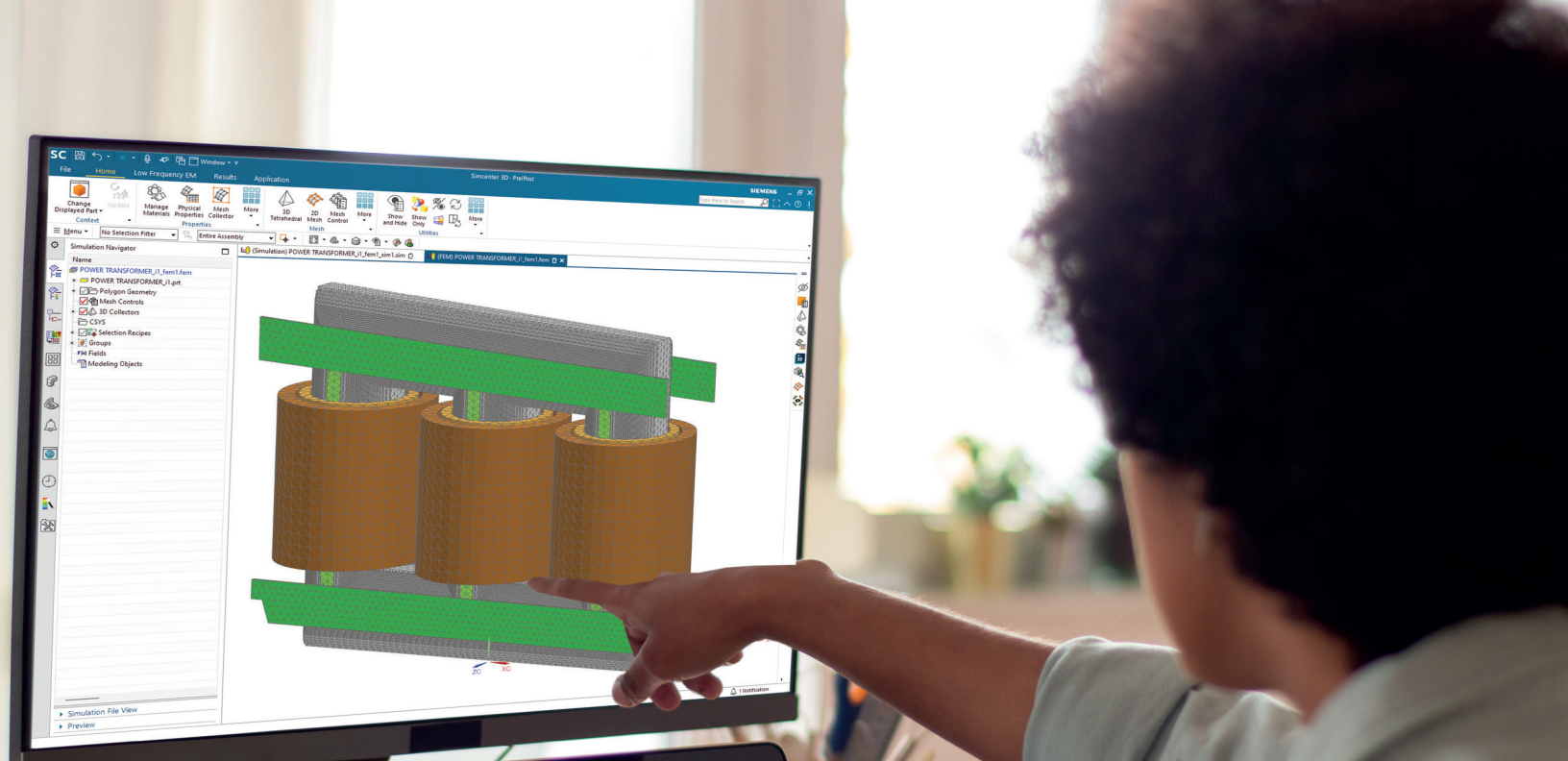

Simcenter 3D

Introduction

Addressing complex engineering challenges by enhancing simulation efficiency

Computer-aided Engineering (CAE) has long proven its value as a troubleshooting tool, but is generally perceived as too slow in providing results to drive development. Traditional CAE tools require tedious geometry clean-up processes, and simulation disciplines are disconnected from each other, hampering efficient workflows.

To meet complex challenges, product engineering teams need a unified, shared platform for all simulation disciplines, with leading-edge analysis tools that are easy-to-use, incorporate more productive workflows and produce consistent results.

Welcome to Simcenter 3D

Simcenter™ 3D software from Siemens Digital Industries Software addresses complex product engineering processes by delivering revolutionary improvements in simulation efficiency. With advanced capability 3D simulation technologies and a comprehensive range of CAE applications, Simcenter 3D offers new methods that increase realism and deliver better insight into your product's performance. Simcenter 3D captures expert knowledge and best-practice workflows, enabling engineers and

analysts to collaborate on a platform that accommodates all aspects of functional performance.

Go faster

Simcenter 3D is an integrated environment in which you do all of your CAE pre- and postprocessing. Within this environment, Simcenter 3D offers what customers often describe as unrivaled geometry manipulation tools that can handle computer-aided design (CAD) data from any source, provide comprehensive meshing and modeling for

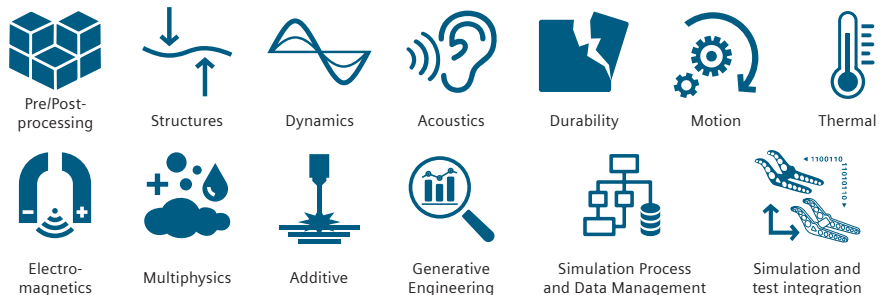

multiple simulation applications, and deliver the unique capability to associate the analysis model to design data. This helps you speed the tedious modeling process and keep analysis models in sync with the latest design. This translates into a much more efficient CAE process than can be achieved with traditional CAE tools.

Model the complexity

Simcenter 3D integrates industry-standard, multidiscipline simulation solvers, all from a centralized engineering environment. The Simcenter 3D simulation solvers for structures, acoustics, structural dynamics, durability, motion, thermal, flow, electromagnetics and more help you to predict real-world performance for a large variety of physics domains. This tight integration of solutions streamlines multi-physics processes that would otherwise be too challenging to perform.

Explore the possibilities

The true value of simulation is not just in reducing the number of physical tests you need, but also in the number of design options that simulation lets you explore. The Simcenter 3D platform lets you automate modification of geometry, simulation model and solution parameters that you can explore with integrated design space exploration tools. Simcenter 3D is also open and scalable so you can use it as a pre- and postprocessing tool for other common, third-party solvers like ANSYS, Abaqus, MSC Nastran and LS-Dyna. This means you can take advantage of the excellent CAD associativity, geometry editing tools, and comprehensive meshing and of Simcenter 3D to explore all of your simulations.

Stay integrated

As part of the Simcenter portfolio of simulation tools, Simcenter 3D integrates with the digital

thread that spans 3D simulation, 1D simulation and testing solutions. You can couple 3D simulations to be part of 1D systems simulations to give systems engineers more accurate results. You can also create reduced order 3D models that take input from physical testing sensors to calculate results in real-time. However, simulation is just part of a larger digital thread starting with your product development processes and continues throughout the life time management of your product. Simcenter 3D helps keep your simulations processes tied to this thread for the lifetime of both the product development, and the product's maintenance. With a seamlessly managed data environment, integrations with systems simulation and physical testing, you can leverage your simulation models earlier and longer than ever before. Your simulation processes are kept in sync with digital development processes like CAD, routing, product requirements, manufacturing process,

Flexible licensing

To make Simcenter 3D even more flexible for your simulation team, Simcenter 3D offers value-based token licensing. Instead of purchasing individual licenses for each add-on module, you can buy packs of tokens that allow you to instantly access most Simcenter 3D products. With value-based licensing, almost the entire suite of Simcenter 3D products is immediately available to you and your team.

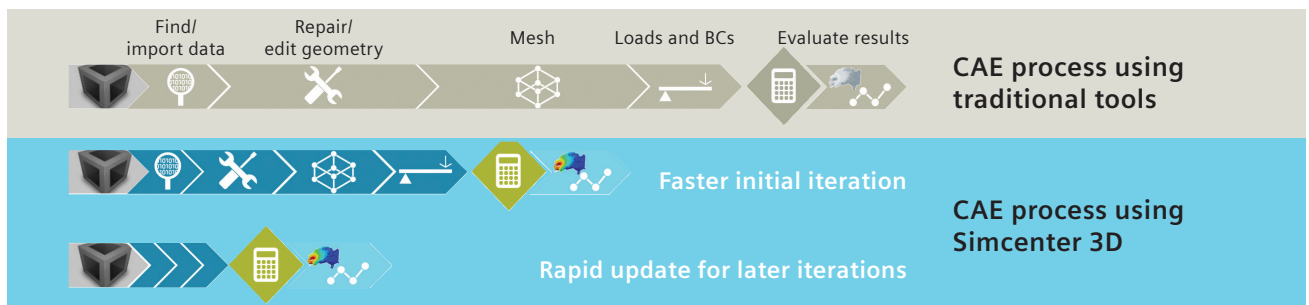

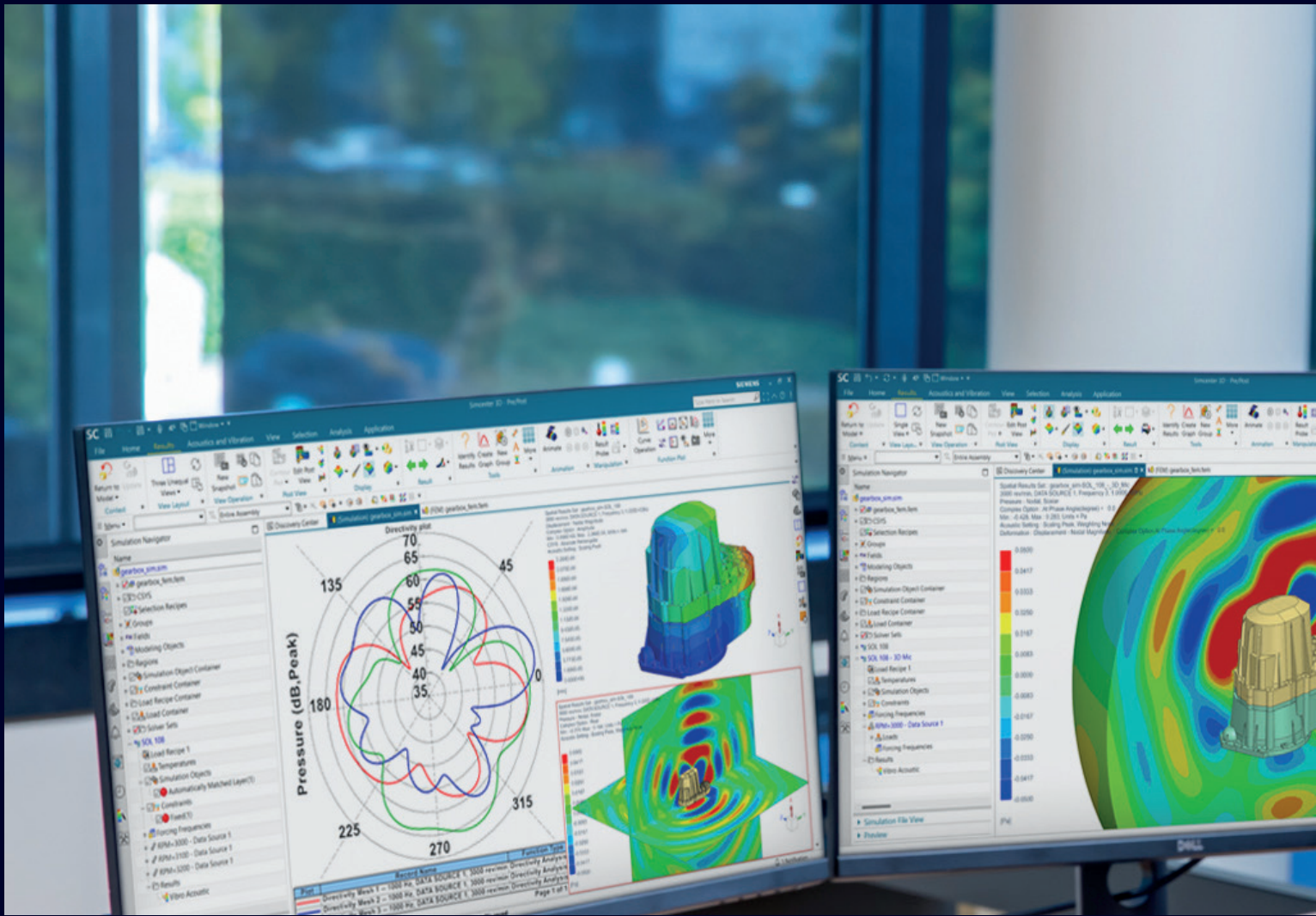

Simcenter 3D is the most comprehensive, fully-integrated CAE solution on the market today, and this solution guide will help you understand what it has to offer for engineering simulation. This guide starts with Simcenter 3D Engineering Desktop, which is the central platform and user interface used to model, perform and evaluate all of your simulations. The rest of the sections outline the physics domains you can work in and the kind of simulations you can perform with Simcenter 3D.

Welcome to the world of Simcenter 3D!



Table of contents

Engineering Desktop	6 – 19	Multiphysics	109 – 118
Structures	20 – 28	Generative engineering	119 – 127
Structural dynamics	29 – 47	Additive manufacturing	128 – 133
Durability	48 – 57	Aerostructures	134 – 140
Acoustics	58 – 76	Simulation process and data management	141 – 146
Motion	77 – 90	Simulation and test integration	147 – 157
Thermal	91 – 101	Appendix	158 – 159
Electromagnetics	102 – 108		

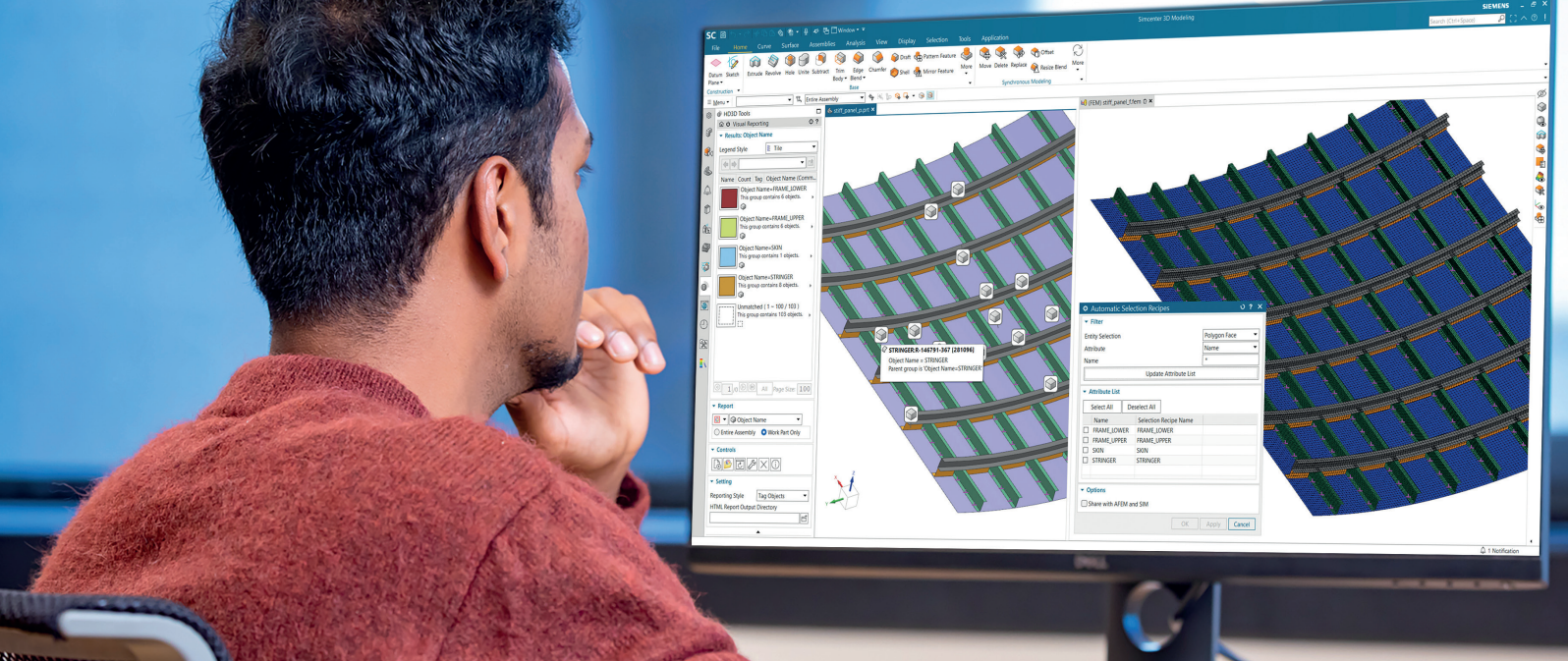

DIGITAL INDUSTRIES SOFTWARE

Simcenter 3D Engineering Desktop

Integrating geometry and FE modeling to streamline product development

Solution benefits

Provide a platform for multidiscipline simulation

Enable fast, intuitive geometry editing

Deliver comprehensive meshing

Efficiently create and manage finite element assemblies

Quickly pre- and postprocess finite element models for popular common finite element solvers

Capture knowledge and automate processes

Simcenter™ 3D Engineering Desktop software is a unified, open and extensible computer-aided engineering (CAE) environment for simulation analysts. Simcenter 3D Engineering Desktop is the hub of the Simcenter 3D platform, and it accelerates the simulation process by helping you to efficiently build the model you need from 3D geometry faster than traditional CAE preprocessors.

Providing a platform for multi-discipline simulation

Simcenter 3D Engineering Desktop sits at the core of a broader, integrated multi-discipline simulation environment. It is the centralized working environment for pre and postprocessing of all Simcenter 3D solutions for structural, dynamics, composites, durability, acoustics,

thermal, flow, motion, optimization, and electromagnetics . This integrated environment helps you to achieve faster CAE processes and streamline multidiscipline simulations that integrate any of the Simcenter 3D solutions together, like thermal-mechanical, vibro-acoustic, or other more complex analyses.



Pre/Postprocessing

SIEMENS

siemens.com/simcenter3d

Simcenter 3D Engineering Desktop

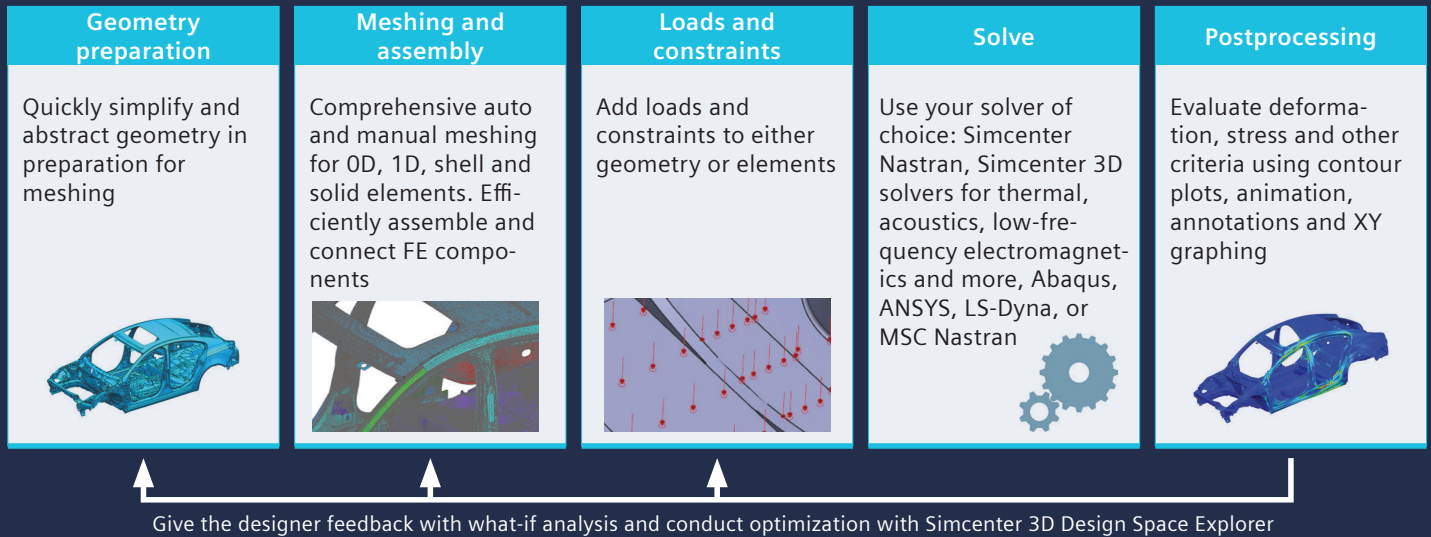

Enabling fast, intuitive geometry editing

Simcenter 3D Engineering Desktop is built on an industry-leading geometry foundation. By using Simcenter 3D Engineering Desktop, you can rapidly clean up and prepare geometry from any computer-aided design (CAD) source using direct modeling. Geometry edits and the complete analysis model remain associated to the base design, which means you can easily update your analysis model each time the design changes. As a result, using Simcenter 3D Engineering Desktop accelerates your design-analysis iterations and improves your overall productivity.

Delivering comprehensive meshing

Simcenter 3D Engineering Desktop includes extensive modeling functions for automatic and manual mesh generation of OD, 1D, 2D and 3D elements, and numerous techniques for applying loads and boundary conditions. The Simcenter 3D Engineering Desktop integrated environment is unique because it associates the analysis model to its geometry so when the design geometry changes, it rapidly updates the existing analysis geometry, mesh, loads and boundary conditions. This approach greatly reduces downstream modeling time, which results in huge time savings across a project's many design-analysis iterations.

Efficiently create and manage FE assemblies

Unlike traditional CAE preprocessors that were developed for component analysis and require you to build monolithic analysis models, the Simcenter 3D Engineering Desktop assembly finite element model (AFEM) management tool enables you to

create large assembly models by instancing and connecting component models together, like a CAD assembly. When an FE component is updated later in development, Simcenter 3D Engineering Desktop updates all instances of that component in the assembly, eliminating the need to rebuild and connect a new FE assembly.

Furthermore, associatively copy and synchronize loads & boundary conditions of multiple simulations to ensure all simulations are using the latest and best data, with the Simulation Interface Manager and Collaborative Simulation.

Supporting multiple common CAE solvers

Take advantage of Simcenter 3D pre and postprocessing benefits with all your FE solvers. Simcenter 3D Engineering Desktop can be used as the primary pre and post processor for Simcenter Nastran® software, or for third-party solvers such as Abaqus, ANSYS, LS-DYNA and MSC Nastran. This is accomplished with immersive user environments that use the selected solver's terminology, which enables analysts to easily prepare solver-specific analysis models without the need to learn new terminology.

Integrated Design Space Explorations

Leverage the power of HEEDS within the Simcenter 3D environment with Simcenter 3D Design Space Explorer. Define constraints, objectives and choose your variable parameters then let HEEDS and its powerful algorithm update variables and run simulations, iteratively improving the design. Finally,

review your results in the Simcenter 3D environment that you are familiar with.

Capturing knowledge and automating processes

Simcenter 3D Engineering Desktop allows engineering organizations to capture the expertise of senior analysts and make that knowledge available to others in the organization. Analysts can capture their workflows via built-in templates that provide end-to-end automation, from the original CAD model to post processed results, and any steps in-between. In addition the workflow can be highly customized via NX™ Open software, an open framework for automation and programming. Analysts can capture the steps of a CAE process and then develop scripts and easy-to-use dialog boxes so others can re-use the same process. Since Simcenter 3D Engineering Desktop is built on top of the same platform as NX CAD, designers who use NX can continue to work in a familiar environment when they perform CAE.

Seamlessly connect with simulation data management

Simcenter 3D Engineering Desktop seamlessly integrates with the entire Teamcenter software data management portfolio, including the simulation process management module. Simulation data management capabilities work out-of-the-box (OOTB), and companies can implement a complete environment for managing CAE data, processes and workflow as part of a wider product development environment. This reduces waste by promoting re-use of existing designs and engineering knowledge. It also synchronizes data and makes it readily accessible using data mining, visualization and reporting. Simcenter 3D also includes a seamless connection to Teamcenter Share for collaboration with partners outside of Teamcenter.

Industry applications

CAE is used across almost all industries today. However, the CAE process is still quite inefficient as engineers can spend upwards of 80 percent of their time on analysis modeling. Simcenter 3D Engineering Desktop can help drastically reduce the time you spend on modeling these industry applications.

Aerospace and defense

Engineers that work on airframes and aircraft engines have vastly different needs for simulation modeling. Simcenter 3D can be used to efficiently handle the large assemblies that airframers need to manage, and it can also easily facilitate building the axisymmetric models that are required for aero engines.

Automotive and transportation

Body-in-white (BIW) modeling is a time-consuming process that requires a connection between hundreds of FE components. Simcenter 3D Engineering Desktop can help automate and reduce the time spent on BIW modeling.

Consumer products

The consumer goods market moves fast, which means your engineers need to move even faster. Simcenter 3D helps you keep pace with rapid design changes so you can quickly simulate the latest iteration of your design.

Industrial machinery

From structural components and rotating equipment to large complex machines, Simcenter 3D Engineering Desktop can help you quickly create the right analysis model.

Marine

Ship models can be quite large, and Simcenter 3D Engineering Desktop has FE assembly management tools that can help you create easy-to-manage structural models.

Simcenter 3D Engineering Desktop

Simcenter 3D Engineering Desktop is a unified, scalable, open and extensible 3D CAE environment for simulation analysts. It accelerates the simulation process by helping you to efficiently build the simulation model you need from 3D geometry faster than traditional CAE preprocessors.

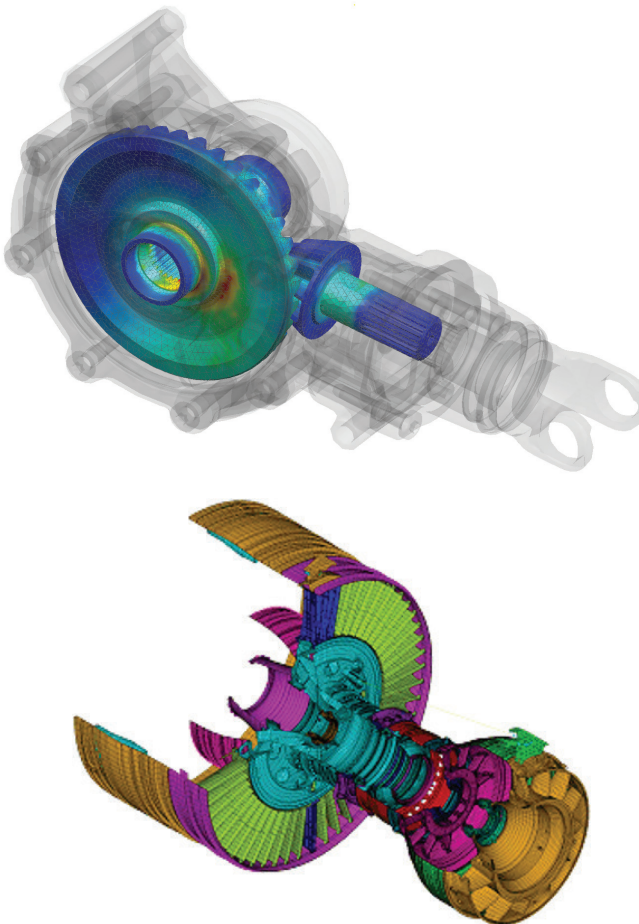

Module benefits

- Accelerate simulation processes by up to 70 percent
- Increase product quality by rapidly simulating design tradeoff studies
- Lower overall product development costs by reducing costly, late design changes
- Efficiently manage large, complex FE assemblies
- Capture and automate best practices and commonly used processes
- Provide pre- and postprocess analysis models for the most popular finite element solvers
- Easily add multidiscipline simulation capabilities as your analysis needs grow

Key features

- An industry-leading geometry foundation for faster geometry editing and abstraction
- Comprehensive meshing tools
- Efficient FE assembly management
- Extensive graphics, plotting and reporting capabilities for postprocessing
- An open and extensible platform
- Seamless integration with simulation data management

Simcenter 3D

Environment for Simcenter Nastran

Included with Simcenter 3D Engineering Desktop, the Simcenter 3D Environment for Simcenter Nastran® software enables you to build finite element models, define solution parameters and view the solution results for the Simcenter Nastran solver. The environment immerses you in familiar Simcenter Nastran language for element definitions, loads and boundary conditions, solution parameters and other common Simcenter Nastran nomenclature. In addition to defining model capabilities, the Simcenter Nastran environment provides bi-directional import/export capabilities that enable you to import current or legacy Simcenter Nastran bulk data files and results as well as export its run-ready data files.

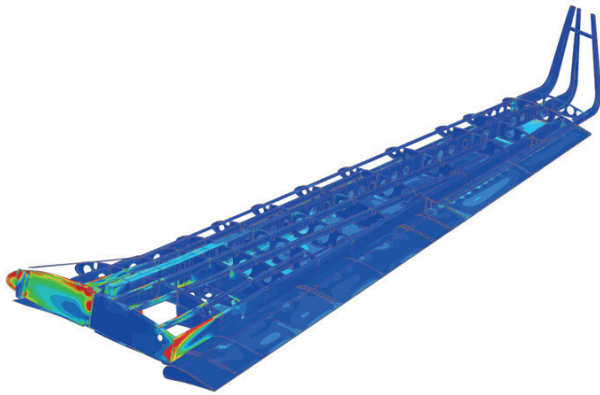

Module benefits

- Simplifies the Simcenter Nastran modeling process by enabling engineers to create analysis models based on geometry or legacy Simcenter Nastran input data files
- Reduces or eliminates intermediate manual processing of data files by generating run-ready decks directly from Simcenter 3D

Key features

- Immerses engineers in the Simcenter Nastran environment by using familiar terminology and extensive support of product-specific elements and entities
- The Simcenter Nastran environment supports a variety of solutions:
 - SOL 101 – Linear statics
 - SOL 103 – Normal modes
 - SOL 105 – Buckling
 - SOL 106 – Nonlinear and linear statics
 - SOL 107 – Direct complex eigenvalues
 - SOL 108 – Direct frequency response
 - SOL 109 – Direct transient response
 - SOL 110 – Modal complex eigenvalues
 - SOL 111 – Modal frequency response
 - SOL 112 – Modal transient response
 - SOL 129 – Nonlinear and linear transient response
 - SOL 153 – Static structural and/or steady-state heat transfer analysis with options: linear or nonlinear analysis
 - SOL 159 – Transient structural and/or transient heat transfer analysis with options: linear or nonlinear analysis
 - SOL 200 – Design optimization with option for only sensitivity analysis
 - SOL 401 – Multistep, structural solution that supports a combination of static (linear or nonlinear) subcases and modal (real eigenvalue) subcases
 - SOL 414 – Rotor Dynamics supports both frequency and time domain solutions, including complex modal analysis (Campbell diagram and critical speeds), maneuver loads, unbalance response, and superelements, for assemblies of rotors, casings and bearings

Simcenter 3D Environment for Abaqus

The Simcenter 3D Environment for Abaqus enables you to build finite element models, define solution parameters and view the solution results for the Abaqus solver. The environment immerses you in familiar Abaqus language for element definitions, loads and boundary conditions, solution parameters and other common Abaqus nomenclature. In addition to defining model capabilities, the Abaqus environment enables bi-directional import/export capabilities that enable you to import its current or legacy data files and results, as well as export run-ready Abaqus input data files.

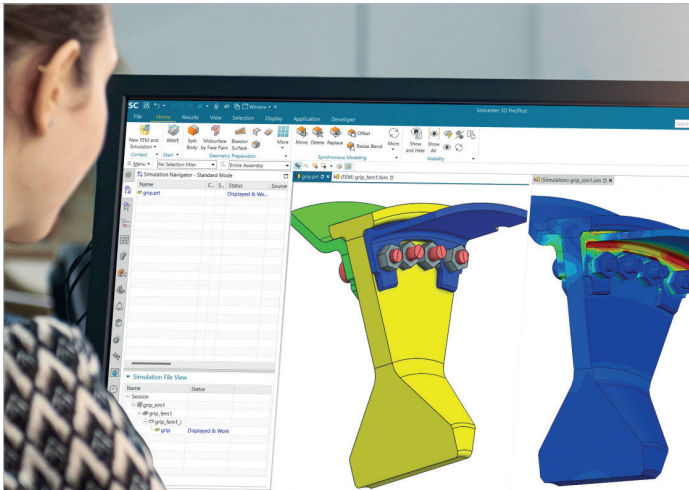

Module benefits

- Simplifies the Abaqus modeling process by enabling you to create analysis models based on geometry or solver input data files
- Reduces or eliminates intermediate manual processing of data files by generating run-ready decks directly from Simcenter 3D

Key features

- General structural
- Static, buckling and frequency perturbation
- Complex eigenvalue extraction
- Implicit dynamic
- Transient modal dynamic
- Steady-state modal dynamic
- Steady-state dynamics subspace projection
- Direct-solution steady-state dynamic
- Response spectrum
- Random response
- Visco
- Direct cyclic analyses
- Modal flexible body
- Substructure generation
- Matrix generation
- Dynamic explicit
- Thermal and coupled thermal-structural analyses:
steady-state and transient heat transfer
- Dynamic coupled thermal-structural analysis

Simcenter 3D Environment for ANSYS

The Simcenter 3D Environment for ANSYS enables you to build finite element models, define solution parameters and view the solution results for the ANSYS solver. The environment immerses you in familiar ANSYS language for element definitions, loads and boundary conditions, solution parameters and other common nomenclature. In addition to defining model capabilities, the ANSYS environment provides bi-directional import/export capabilities that enable you to import its current or legacy data files and results, as well as export run-ready ANSYS input data files.

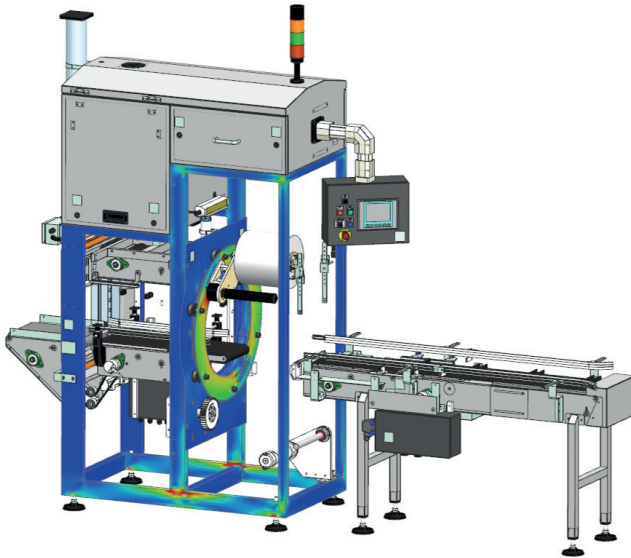

Module benefits

- Simplifies the ANSYS modeling process by enabling you to create analysis models based on geometry or legacy input data files
- Reduces or eliminates intermediate manual processing of data files by generating run-ready decks directly from Simcenter 3D

Key features

- Immerses you in the ANSYS environment by using familiar terminology and extensive support of specific elements and entities of ANSYS
- Supported solutions include:
 - Structural and axisymmetric structural linear and nonlinear statics
 - Linear and nonlinear buckling
 - Modal
 - Modal flexible body (for use in Simcenter 3D Motion analysis)
 - Mode superposition harmonic
 - Full method harmonic
 - Mode superposition transient dynamic
 - Full method transient dynamic
 - Cyclic symmetry analysis for linear static, modal, nonlinear static, or harmonic – mode superposition
 - Steady-state thermal and axisymmetric thermal
 - Thermal transient
 - Coupled-fields thermal-structural

Simcenter 3D Environment for LS-Dyna

The Simcenter 3D Environment for LS-Dyna enables you to build finite element models and define solution parameters for the LS-Dyna solver. The environment immerses you in familiar LS-Dyna language for element definitions, loads and boundary conditions, solution parameters and other common LS-Dyna nomenclature. In addition to defining model capabilities, the LS-Dyna environment enables bi-directional import/export capabilities that allow you to import current or legacy data files and results, as well as export run-ready LS-Dyna input data files.

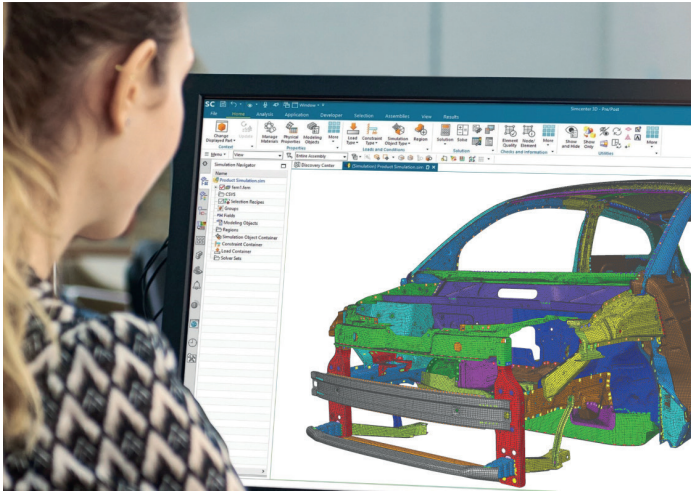

Module benefits

- Simplifies the LS-Dyna modeling process by enabling you to create analysis models based on geometry or legacy LS-Dyna input data files
- Reduces or eliminates intermediate manual processing of data files by generating run-ready decks directly from Simcenter 3D

Key features

- Immerses you in the LS-Dyna environment by using familiar terminology and supporting specific product elements and entities
- Supports general structural impact solution

Simcenter 3D

Environment for MSC Nastran

The Simcenter 3D Environment for MSC Nastran software enables you to build finite element models, define solution parameters and view the solution results for the MSC Nastran solver. The environment immerses you in familiar MSC Nastran language for element definitions, loads and boundary conditions, solution parameters and other common MSC Nastran nomenclature. In addition to model definition capabilities, the MSC Nastran environment provides bi-directional import/export capabilities that enable you to import current or legacy MSC Nastran bulk data files and results as well as export run-ready data files.



Module benefits

- Simplifies the MSC Nastran modeling process by enabling you to create analysis models based on geometry or legacy MSC Nastran input data files
- Reduces or eliminates intermediate manual processing of data files by generating run-ready decks directly from Simcenter 3D

Key features

- Immerses you in the MSC Nastran environment by using familiar MSC Nastran terminology and extensive support of product-specific elements and entities
- There are a variety of supported solutions:
 - SOL 101 – Linear statics
 - SOL 103 – Normal modes
 - SOL 105 – Buckling
 - SOL 106 – Nonlinear or linear statics
 - SOL 107 – Direct complex eigenvalues
 - SOL 108 – Direct frequency response
 - SOL 109 – Direct transient response
 - SOL 110 – Modal complex eigenvalues
 - SOL 111 – Modal frequency response
 - SOL 112 – Modal transient response
 - SOL 129 – Nonlinear or linear transient response
 - SOL 153 – Static structural and/or steady-state heat transfer analysis with options: linear or nonlinear analysis
 - SOL 159 – Transient structural and/or transient heat transfer analysis with options: linear or nonlinear analysis
 - SOL 200 – Design optimization with option for only sensitivity analysis

Simcenter 3D Environment for ADINA

The Simcenter 3D Environment for ADINA enables you to build finite element models, define solution parameters and view the solution results for the ADINA solver using the Nastran interface. The environment immerses you in familiar ADINA language for element definitions, loads and boundary conditions, solution parameters and other common ADINA nomenclature. In addition to defining model capabilities, the ADINA environment enables bi-directional import/export capabilities that enable you to import its current or legacy data files and results, as well as export run-ready ADINA input data files.

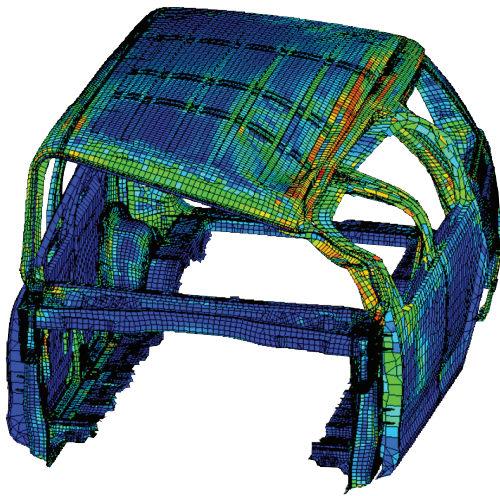

Module benefits

- Simplifies the modeling process by enabling you to create analysis models based on geometry or legacy input data files for ADINA in the Nastran format
- Reduces or eliminates intermediate manual processing of data files by generating run-ready decks directly from Simcenter 3D

Key features

- Immerses you in the ADINA environment by using familiar terminology and extensive support of specific elements and entities of ADINA
- Solve geometric, material, and contact nonlinearities in static or dynamic (implicit or explicit) analyses
- Supported solutions include:
 - SOL 601,106 Advanced Nonlinear Statics (implicit static)
 - SOL 601,129 Advanced Nonlinear Transient (implicit transient dynamic)
 - SOL 701 Explicit Advanced Nonlinear Analysis (explicit transient dynamic for full structural analyses only, not axisymmetric structural)

Simcenter 3D

Laminate Composites

Simcenter 3D Laminate Composites features easy-to-use ply and laminate definition tools which help you create and validate composite structure models. You can use Simcenter 3D Laminate Composites to prepare models for the Simcenter Nastran, MSC Nastran, Ansys, Abaqus, or LS-Dyna solvers. Laminate post reporting processes solver stresses or shell resultants to generate contour and tabular results, including envelopes of ply stresses, strains and failure metrics over multiple load cases.

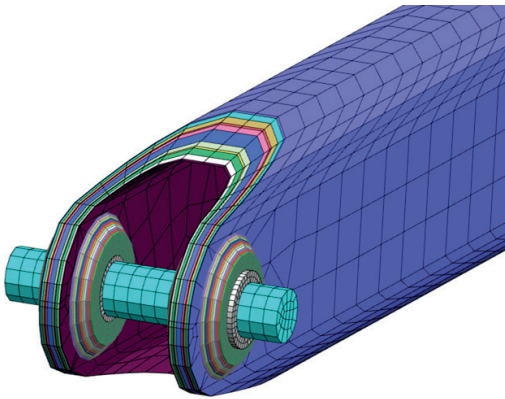

Module benefits

- Reduce laminate model creation time by choosing between zone-based modeling, ply-based modeling or a mixture of both approaches
- Leverage the open solver architecture of Simcenter 3D to perform state-of-the-art dynamic, nonlinear, progressive failure and delamination simulations

Key features

- Define laminates on 2D meshes, 3D meshes or both
- Keep your model up-to-date with the latest design using geometry associativity
- Interact with computer-aided design (CAD) based composites definitions from Fibersim, CATIA and others
- Use Simcenter standard materials, or create ply materials from the constituent fiber and matrix material properties, to simulate plies made of woven, unidirectional, randomly oriented short fibers and particulates and represent cores
- Conveniently assign laminates and plies to your choice of geometry, meshes and/or elements
- Improve finite element modeling accuracy by accounting for distorted fiber orientations
- Postprocessing tools allow you to quickly identify critical plies and load cases using classical and user-defined failure theories and create reports

Capabilities chart

Simcenter 3D Engineering Desktop

General capabilities	Specific capabilities	Simcenter 3D Engineering Desktop
Preprocessing		
Geometry import	Neutral geometry transfer (IGES, STEP, the JT™ data format, Parasolid® software)	•
	Direct geometry transfer (CATIA V4, CATIA V5, Pro/E)	+
Geometry modeling	Parasolid® software geometry kernel	•
	Parametric solid and surface modeling	•
	Direct modeling with synchronous technology	•
	Feature modeling	•
	Assembly structure creation	•
	Interpart relationship	•
	Configurations	•
	Convergent modeling (facet body editing)	+
Geometry editing prior to meshing	Direct editing with synchronous technology	•
	Defeature tools (geometry repair, feature suppression, stitch surface, remove hole/fillet, partitioning)	•
	Non-manifold topology generation for volumes	•
	Mid-surfacing (constant and variable thickness)	•
	Automatic topology abstraction	•
	Manual topology modification tools	•
	Create surface from mesh face	•
	Accept convergent model as input, push convergent model to NX CAD module	•
Meshing and modeling	Beam modeling	•
	Automated bolt connection meshing	•
	Automated shell meshing	•
	2D mapped meshing	•
	Automated tetrahedral meshing	•
	Swept hexahedral meshing	•
	Surface coating	•
	Automated hexahedral dominant meshing	•
	Transition meshing	•
	Axisymmetric meshing	•

General capabilities	Specific capabilities	Simcenter 3D Engineering Desktop
Meshing and modeling (continued)	Batch meshing	•
	Mesh quality checks	•
	Material property creation and management	•
	Mass property calculations	•
	Physical property creation and management	•
	Variable element thickness	•
Finite element assemblies	Grouping	•
	Hierarchical assembly management	•
	Efficient connection modeling	•
	Superelement support	+
	FE and test-based data hybrid modeling	+
Boundary conditions	Apply on geometry	•
	Apply to local coordinate system	•
	Apply on FE entities	•
	Apply on groups	•
	Axisymmetric boundary conditions	•
	Automatic contact detection and setup	•
	Automated load transfer from motion analysis	•
	Import test measurement data from and map to finite element model (load recipe)	•
External solver data deck support (import and export)	Simcenter Nastran	•
	Abaqus	+
	ANSYS	+
	LS-Dyna	+
	MSC Nastran	+
	ADINA - Nastran interface	+
Analysis model to design associativity	Automatic analysis model update based on geometry change	•
	Perform automated parametric analysis	•

Legend:

- = included in module
- + = additional product required

General capabilities	Specific capabilities	Simcenter 3D Engineering Desktop
Postprocessing		
Contour displays		•
Beam cross-section contour displays		•
Vector displays		•
Isosurface displays		•
Cutting planes		•
Advanced lighting control		•
Animations		•
Complex dynamic response results		•
Multiple viewports		•
Probing of results on nodes		•
Postprocessing data table with sort/criteria		•
Results listings		•
Transparency display		•
Local coordinate system		•

General capabilities	Specific capabilities	Simcenter 3D Engineering Desktop
	XY graphing	•
	Bar graphing	•
	Synchronized contour and XY plotting displays	•
	Annotated graphs	•
	Output (JT, postscript, tif, etc.)	•
	Enhanced acoustics and NVH postprocessing	+
External solver result file support	Simcenter Nastran	•
	Abaqus	+
	ANSYS	+
	LS-Dyna	+
	MSC Nastran	+
	ADINA - Nastran interface	+

Legend:
 • = included in module
 + = additional product required

Simcenter 3D solver environments

General capabilities	Specific capabilities	Simcenter 3D Environment for Simcenter Nastran	Simcenter 3D Environment for Simcenter BEM Acoustics	Simcenter 3D Environment for Abaqus	Simcenter 3D Environment for ANSYS	Simcenter 3D Environment for LS-Dyna	Simcenter 3D Environment for MSC Nastran	Simcenter 3D Environment for ADINA
Supported analysis types								
Structural analysis	Linear statics	•		•	•		•	
	Normal modes	•		•	•		•	
	Buckling	•		•	•		•	
	Nonlinear	•		•	•		•	•
	Axisymmetric structural	•		•	•	•	•	•
Structural dynamics	Modal frequency response	•		•	•		•	
	Direct frequency response	•		•	•		•	
	Modal transient response	•		•	•		•	
	Direct transient response	•		•	•		•	
	Random response	•		•				
	Complex modes	•		•				
	Superelements	•		•			•	
	Flexible bodies (for motion simulation)	•		•	•		•	
	Dynamic explicit			•		•		
	Axisymmetric dynamic explicit			•		•		
	Response spectrum			•				

General capabilities	Specific capabilities	Simcenter 3D Environment for Simcenter Nastran	Simcenter 3D Environment for Simcenter BEM Acoustics	Simcenter 3D Environment for Abaqus	Simcenter 3D Environment for ANSYS	Simcenter 3D Environment for LS-Dyna	Simcenter 3D Environment for MSC Nastran	Simcenter 3D Environment for ADINA
Supported analysis types (continued)								
Advanced dynamics	Coupled fluid-structure (vibro-acoustic) analysis	•						
	Frequency response functions (FRF)	+						
	Recursive domain normal modes (RDMODES)	•						
	Fast frequency response (FASTFR)	•						
	Modal representation	+						
Thermal	Steady-state heat transfer	•		•	•		•	
	Transient heat transfer	•		•	•		•	
	Axisymmetric thermal	•		•	•			
Acoustics	Acoustic eigenvalues (normal modes, natural freq)	•						
	Frequency response	•	•					
	Transient response		•					
	Vibro-acoustics	•	•					
Multiphysics	Coupled thermal-mechanical	+		•	•			
	Coupled fluid-structure interaction	+						
	Coupled thermal-flow-structural	+						

Legend:

- = included in module
- + = additional product required

Note: Simcenter 3D Engineering Desktop is a minimum prerequisite for all Simcenter 3D products. Other dependency or prerequisites may apply for individual products.



DIGITAL INDUSTRIES SOFTWARE

Simcenter 3D for structural simulation

Increasing realism and improving insight

Solution benefits

Reduce risk and cost while developing innovative structures

Investigate product performance virtually in all possible operating conditions, including thermally influenced operating conditions

Obtain more accurate solution results than linear analysis when standard linear assumptions are not valid

Improve confidence in final designs by virtually investigating your product's performance in all possible operating conditions

Simcenter™ 3D software for structural simulation offers a set of finite element (FE) structural solvers that are part of the Simcenter portfolio of simulation tools. They are used by engineers across industries as part of their product development process to evaluate the structural performance of their systems.

Providing finite element solution for experienced CAE analysts

Simcenter 3D for structures is powered by the well known Simcenter Nastran® software.

Structural solutions of Simcenter 3D offer scalable, open and extensible capabilities for both general and advanced analysts. They can be used on

laptop, workstation and servers to solve everything from small models to the largest state-of-the-art industrial models.

Simcenter Nastran is available with enterprise licensing, which means it can be used independently from Simcenter pre/post solutions and can run on Windows and Linux operating systems.

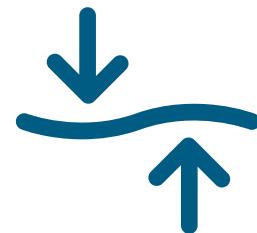

Structures

SIEMENS

[siemens.com/simcenter3d](https://www.siemens.com/simcenter3d)

Simcenter 3D for structural simulation

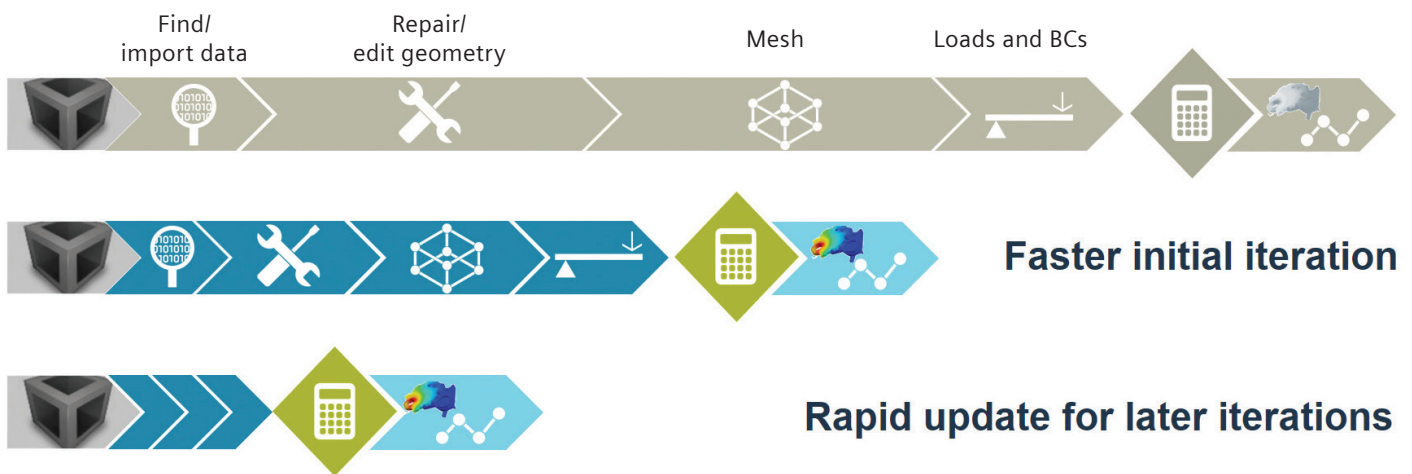

Reduce risk by using simulation to save time and cost

Simcenter 3D software addresses complex product engineering by delivering significant improvements in simulation efficiency. With advanced-capability 3D simulation technologies and powerful model preparation technology, Simcenter 3D offers new methods that increase realism and deliver better insight.

Accelerate innovation with rapid iterations

Synchronous technology in Simcenter 3D helps you reduce the time spent on model abstraction and geometry editing. Meshes, loads and boundary conditions are all associated with the base design, so when the design topology changes, you can rapidly update your simulation results. The solvers and analysis tools provide all the accuracy and speed you need for timely simulation-driven insights.

Investigate product performance virtually under all possible operating conditions

Simcenter 3D includes solvers that enable you to dive deep into the physics. Every application specialist will find state-of-the-art technology that fits the problem – static or dynamic, linear or nonlinear, composite or other, including temperature-dependant materials and thermal loads acting on a structure.

Co-simulation with Simcenter Nastran

Beyond structural solutions, Simcenter Nastran also enables co-simulation of structural, thermal and flow physics. A dedicated multiphysics environment allows you to define the complete solution on a single model, making co-simulation easily accessible to a broad set of users.

A platform for multidiscipline simulation

The Simcenter 3D structural simulation solution is part of a larger, integrated multidiscipline simulation environment with the Simcenter 3D Engineering Desktop at the core for centralized pre-/postprocessing for all Simcenter 3D solutions. This integrated environment helps you to achieve faster CAE processes and streamline multidiscipline simulations that integrate structural simulation with other disciplines like thermal simulation, fluid dynamics, multibody dynamics, or electromagnetics simulation.

Industry applications

Simcenter Nastran has helped manufacturers as well as engineering suppliers in many industries with their critical engineering computing needs so they can produce safe, reliable and optimized designs within increasingly shorter design cycles.

Aerospace and defense

Utilizing Simcenter 3D gives aerospace engineers a comprehensive toolkit for various applications. When analyzing the airplane frame, tools are available to assess stiffness, frame durability, and modal frequency, ensuring structural integrity and performance. When analyzing the wings, simulation can measure stiffness, skin buckling resistance, and modal frequency to maintain aerodynamic efficiency and safety. The airplane hatch's seals and structural strength are meticulously examined to prevent failures that could jeopardize the aircraft's integrity.

For the airplane's control surfaces and support structures, pylons, ailerons, and stabilizers can be evaluated for stiffness and overall strength, safeguarding against the intense forces encountered during flight.

For spacecraft, Simcenter 3D provides capabilities for analyzing thermal stress and distortion, using composites, and modal frequencies, essential for ensuring durability and reliability in the harsh conditions of space.

Simulation of aero engines offers insights into rotating loads, distortion, including for a choice of materials like composites, and detailed analyses of compressor and turbine components. These evaluations include thermal stress, lifing, bolt stresses, and distinct considerations like cyclic symmetry, axisymmetry, and, in the case of turbines, creep and break-out modeling.

Launch vehicles and their structures also benefit from simulation, with tools to assess thermal stress, maneuver and payload bracket loads, as well as the effects of wind and launch loads, critical for successful missions.

Finally, the casing of aero engines, vital for enclosing and protecting critical components, can be thoroughly assessed for its ability to withstand bearing and maneuver loads.

Automotive – Ground vehicles

Simcenter 3D offers automotive simulation engineers a comprehensive suite of tools geared toward enhancing vehicle design and performance. The software enables detailed analysis of the vehicle body, including assessments of roof crush resistance, panel strength, stiffness, and frame durability. For powertrain and driveline components, it provides insights into managing torque loads and mitigating thermal stress and distortion. The chassis functionality allows for the examination of harshness loads and suspension deflections, crucial for optimizing ride quality.

Moreover, it caters specifically to the needs of off-highway vehicles by evaluating strength, durability, rollover protective structures (ROPS), and overall stability. Manufacturing tools within the suite aid in predicting and preventing defects by analyzing thermal stress, modal frequency, and bolted stresses. Lastly, it includes features for assessing the stability and stress resistance of support structures, ensuring they meet rigorous demands. Simcenter 3D streamlines the process of creating safer, more efficient vehicles through its versatile and robust toolset.

Marine

Simcenter 3D offers marine engineers specialized tools for evaluating ship integrity and performance, including analyses of stiffness, deformation, and strength for entire ships, as well as detailed inspections of hull skin rupture risks and bulkhead structural strength. This ensures vessels meet maritime standards, maintaining safety and integrity.

Electronics

Using Simcenter 3D, electronics simulation engineers have tools to ensure the durability and reliability of their designs. This includes drop simulations and stress analysis for hand-held devices, thermal stress, and distortion checks for printed circuit boards (PCBs). For electronic boxes, engineers can evaluate bracket strength and analyze modal frequencies, enhancing the product's structural integrity and performance.

Consumer goods

Using Simcenter 3D, a consumer goods simulation engineer can extensively evaluate packaging, focusing on its strength, stability, hyperelasticity, and creep. This ensures durability and performance under different conditions.

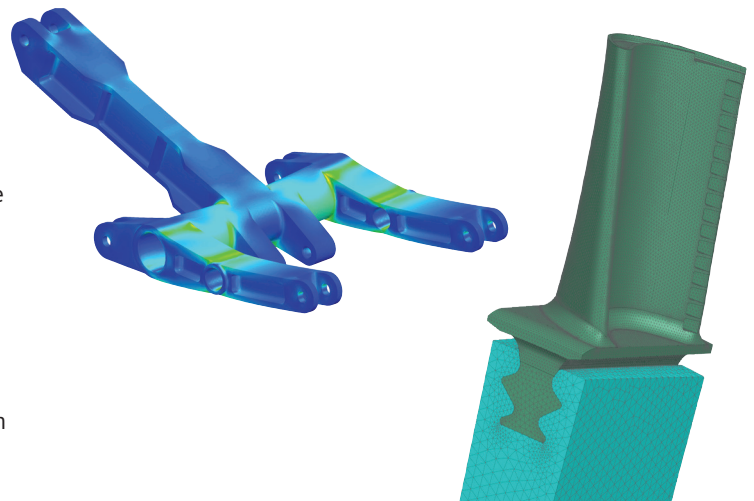

Simcenter 3D Structures

Simcenter 3D Structures software is a unified, scalable, open and extensible 3D computer-aided engineering (CAE) environment for simulation analysts. Simcenter 3D Structures is a bundle combining the Simcenter 3D Engineering Desktop, Simcenter Nastran environment and the Simcenter Nastran Basic solver. Together, Simcenter 3D Structures gives you best-in-class simulation modeling with the power to perform basic structural analysis with an industry-standard solver. The Simcenter 3D Engineering Desktop contained in Simcenter 3D Structures speeds the simulation process by helping you efficiently build the simulation model you need from 3D geometry faster than traditional CAE preprocessors. The integrated Simcenter Nastran solver in Simcenter 3D Structures lets you seamlessly submit analysis models for linear statics, normal modes, buckling and basic heat transfer analyses. Simcenter 3D Structures also forms the foundation on which you can add additional solutions for structural dynamics, multistep nonlinear, thermal, flow, acoustics, motion, optimization and multiphysics analyses, all from a single environment.

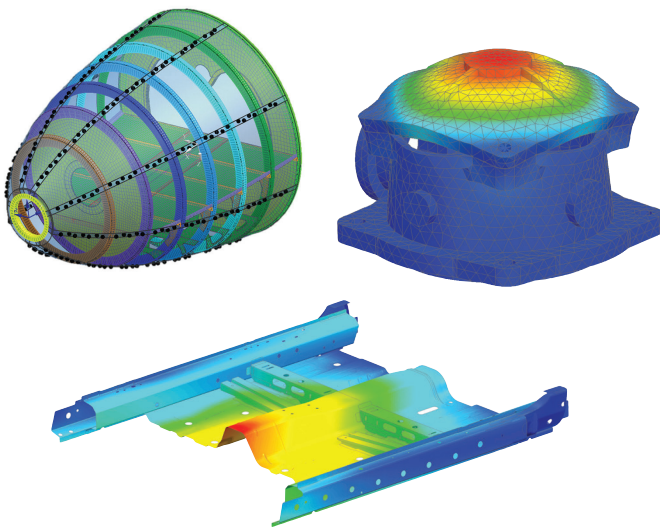

Module benefits

- Speed simulation processes by up to 70 percent
- Perform accurate, reliable structural analysis with the integrated Simcenter Nastran Basic solver
- Increase product quality by rapidly simulating design tradeoff studies
- Lower overall product development costs by reducing costly, late design change orders
- Efficiently manage large, complex analysis models
- Capture and automate best practices and commonly used processes
- Easily add multidiscipline simulation capabilities as your analysis needs grow

Key features

- All-inclusive software package with Simcenter 3D Engineering Desktop for pre/post together with Simcenter Nastran Basic for structural analysis
- NX is a leading geometry kernel which is used as part of Simcenter 3D to provide rapid geometry editing and abstraction
- Comprehensive meshing tools combined with efficient FE assembly management
- Immerses engineers in the Simcenter Nastran environment by using familiar terminology and extensive support of product-specific elements and entities
- Simulate structural analysis for linear statics, normal modes, buckling and heat transfer using the trusted Simcenter Nastran solver

Simcenter Nastran

Simcenter Nastran allows you to initiate digital simulation into your product development process by providing access to a broad library of finite element types and material models, robustly manipulating load cases and delivering several efficient solution sequences for analyses on models of unlimited size. You can also perform sensitivity studies based on these analysis types.

The Simcenter Nastran basic license comes with a full base set of structural capabilities as the entry point for Simcenter Nastran. It also comes with a basic heat transfer solver and the resulting temperatures can be used as loads in a structural solution.



Module benefits

- Reduce risk by using simulation to save time and cost compared to physical test cycles
- Accelerate innovation with rapid iteration and numerous what-if studies
- Investigate product performance virtually under all possible operating conditions, including thermally influenced operating conditions

Key features

- Linear statics, normal modes, buckling
- Design sensitivity
- Basic nonlinear
- Composites
- Shared memory parallel (SMP) processing

Beyond the base set of capabilities, users can add more advanced structural capabilities including:

- Multistep nonlinear (static, transient)
- Distributed memory parallel (DMP) processing
- Linear dynamics (transient, frequency, random)
- Rotor dynamics
- Design and topology optimization
- Aeroelastic
- Vibroacoustic

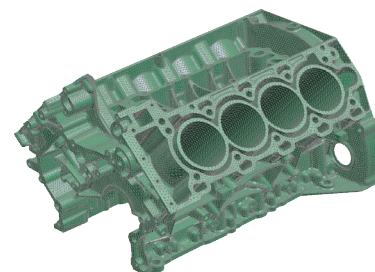
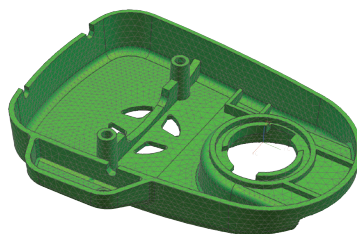
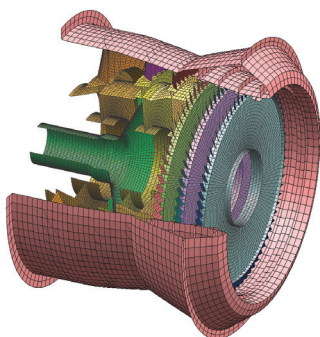

Simcenter Nastran Multistep Nonlinear

Simcenter Nastran Multistep Nonlinear is an advanced solution that provides comprehensive capabilities for geometric nonlinear, contact, plasticity, creep, hyperelasticity and other material behaviors. The multistep solution allows users to set up sequential subcases for preload, nonlinear statics, nonlinear transient, modal, buckling, post buckling, harmonic modes and frequency response.

This is an add-on product to a basic license that provides two nonlinear solution options: Simcenter Nastran solution SOL 401 and SOL 402. Both are suited to a similarly wide range of nonlinear problems, but each also has unique features.

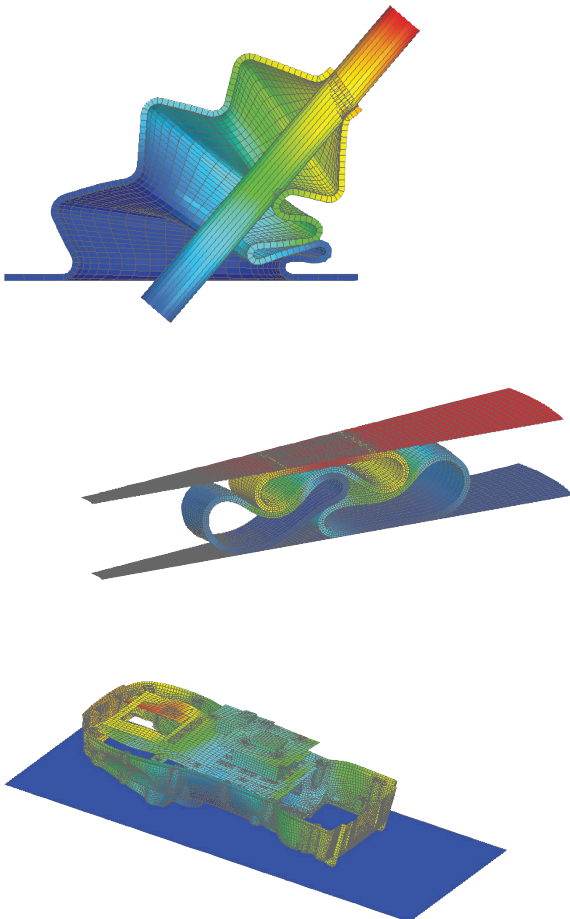

Module benefits

- Use the same models already built and analyzed linearly with Simcenter Nastran Basic
- Improve confidence in final designs by virtually investigating your product's performance under all possible operating conditions
- Obtain more accurate solution results than linear analysis when standard linear assumptions are not valid

Key features

- Static/dynamic analysis of models, including material and geometrical nonlinear behaviors
- Multistep solver allowing the following analysis types in different steps: static, dynamic, preload, modal, buckling, cyclic symmetry modes, Fourier harmonic modes
- Material nonlinear: hyperelasticity models (Mooney-Rivlin, Ogden, hyperfoam, Mullins effect, damping with Prony series), elastoplastic (Von Mises yield criterion, isotropic hardening, kinematic hardening, mixed hardening), thermal elastoplastic, creep, combined creep and elastoplastic
- Geometrical nonlinear: Large deformations, large strain, snap-through analysis (post buckling), follower forces
- Contact: Shell and solid element face contact, edge contact for axisymmetric modeling, single- and double-sided contact, self-contact, multiple friction models, tied contact, contact surface offsets, gap elements, contact activation/deactivation per subcase, contact pressures and force results, contact separation and sliding results

Simcenter Nastran DMP

Simcenter Nastran DMP is an add-on module to Simcenter Nastran Basic. It enables parallel processing using distributed memory. It is an efficient approach to solving large models and can be used on workstations with multiprocessors using Windows. DMP solutions are available for static solves (SOL 101), modal eigenvalue solves (SOL 103), modal dynamic response solves (SOL 111 and 112), direct frequency solves (SOL 108) and nonlinear solves (SOL 401 and SOL 402). DMP can also be used in combination with SMP, which comes as part of Simcenter Nastran Basic.

Module benefits

- More cores provide faster solutions
- Allows solving large models that are not possible to solve on a single central processing unit (CPU)

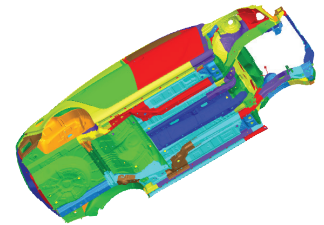
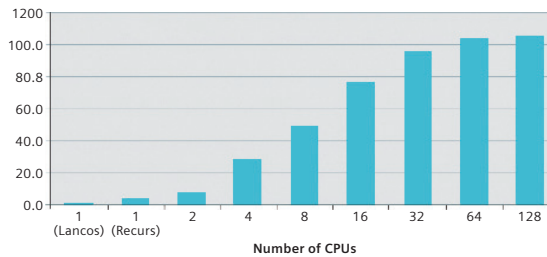
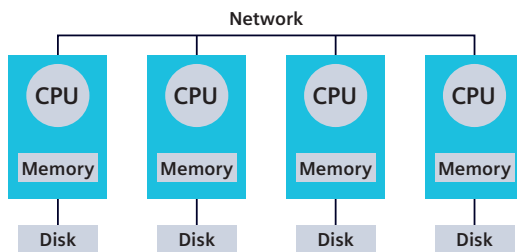

Capabilities chart

General capabilities	Specific capabilities	Simcenter 3D Structures	Simcenter Nastran Basic	
Linear structural solutions	Statics	•	•	
	Dynamics (see Simcenter 3D for structural dynamics for details)			
	Normal modes	•	•	
	Buckling	•	•	
	Restarts	•	•	
	Parallel memory processing	•	•	
	Elements			
	3D solids	•	•	
	2D solids	•	•	
	Shell	•	•	
	Membrane	•	•	
	Beam	•	•	
	Springs	•	•	
	Rods	•	•	
	Rigid	•	•	
	Composites			
	Short fiber	•	•	
	Long fiber	•	•	
	Connections			
	Bolt preloads	•	•	
	Contact connections	•	•	
	Glue connections	•	•	
	Materials			
	Isotropic	•	•	
	Orthotropic	•	•	
	Anisotropic	•	•	
	Temperature dependence	•	•	
	Loads/boundary conditions			
	Gravity	•	•	
	Force/moment	•	•	
	Pressure	•	•	
	Rotational	•	•	
Temperature	•	•		
Enforced motion	•	•		

General capabilities	Specific capabilities	Simcenter 3D Structures	Simcenter Nastran Basic	Simcenter Nastran Multistep Nonlinear	
Nonlinear structural solutions	Large displacement effect			•	
	Large strain effect			•	
	Contact	•	•	•	
	– Coulomb friction	•	•	•	
	– Other friction models			•	
	Nonlinear materials				
	Plasticity			•	
	– Temperature dependence			•	
	– Bilinear			•	
	– Multilinear			•	
	– Isotropic hardening			•	
	– Kinematic hardening			•	
	Creep			•	
	Hyperelastic material			•	
	Nonlinear elastic material			•	
	Gasket material			•	
	User defined material			•	
	Composite				
	Cohesive delamination			•	
	Progressive failure			•	
	Algorithms				
	Static nonlinear			•	
	Transient nonlinear			•	
	Thermal mechanical co-simulation			•	
	Fluid-structural co-simulation			•	
	Modal about nonlinear state			•	
	Complex modal about nonlinear state			•	
	Buckling about nonlinear state			•	
	Multistep			•	
	Arc-length			•	
	Cyclic symmetry modes			•	
	Multi-harmonic modes			•	
Restart			•		
Element add/remove			•		

General capabilities	Specific capabilities			
Nonlinear structural solutions (continued)	Loads/boundary conditions (for nonlinear analyses only)	Simcenter 3D Structures	Simcenter Nastran Basic	Simcenter Nastran Multistep Nonlinear
	Distributed force			•
	Fluid pressure penetration			•
	Initial stress/strain			•
	Geometry imperfections			•

Legend:

• = included in module

Note: Simcenter Nastran Multistep Nonlinear is an add-on module to either Simcenter 3D Structures or Simcenter Nastran Basic.

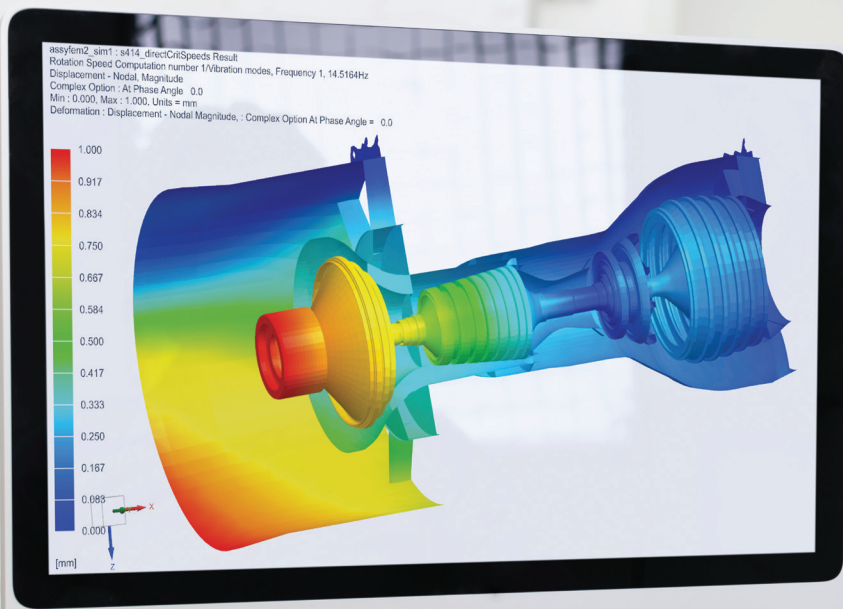

DIGITAL INDUSTRIES SOFTWARE

Simcenter 3D for structural dynamics simulation

Providing rapid insight into the dynamic response of structural systems

Solution benefits

Perform comprehensive dynamic analysis and accelerate product time-to-market

Improve confidence in design by using Simcenter Nastran to investigate the product's performance under dynamic operating conditions

Get insight and improve NVH performance by dedicated tool set for NVH postprocessing and troubleshooting

Combine FE with measured data as loading or component's description for more realistic simulations and hybrid assemblies

Rapidly evaluate and improve the dynamic performance of rotating systems

Improve accuracy and increase confidence in your FE models by correlating with actual measured data

Simcenter™ 3D software offers a comprehensive solution to understand, analyze and improve the response when a system is subjected to dynamic loading. This includes the industry standard Simcenter Nastran® software for dynamic analysis as well as interactive solutions for general dynamic analysis in order to efficiently understand and avoid excessive vibrations and stresses. Moreover, dedicated capabilities are available for noise, vibration and harshness (NVH) engineering, rotor dynamics and correlation.

Advancing structural dynamics prediction

Starting from the product concept phase, analysts and specialists can rely on

Simcenter 3D structural dynamics solutions to analyze design decisions and systematically improve dynamic characteristics of the system. The graphical user interface (GUI) of Simcenter 3D is fully customizable to suit your dynamic analysis processes by creating predefined templates and streamlining the product engineering process.

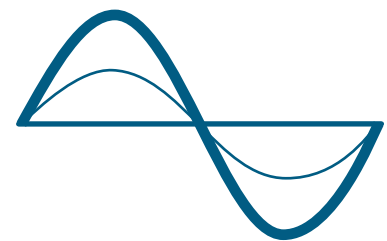





Dynamics

SIEMENS

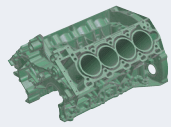
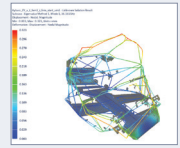
[siemens.com/simcenter3d](https://www.siemens.com/simcenter3d)

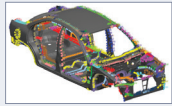
Simcenter 3D for structural dynamics simulation

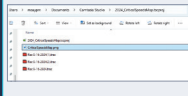
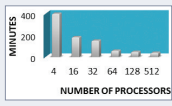
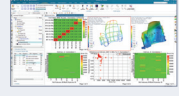
Preprocessing	Correlation and model update	Multilevel assembly	Connections modeling	Cavity mesh	Loads	Solution	Postprocessing														
<p>Defeaturing, synchronous technology, convergent modeling, multi-CAD support, component meshing, boundary conditions</p> 	<p>Pretest sensor and exciter placement, Modal Correlation (MAC, CoMAC, X-Orthogonality), FRF Correlation (FRAC), Sensitivity-based Model Updating, Simcenter Testlab interfaces</p> 	<p>Component models sub-assembly, hybrid modeling with test modes and FRFs, automatic assembly label resolution</p> 	<p>Universal connections, automated weld, joints, spring, damper bolt, and sealing identification</p> 	<p>Solid to shell meshing, surface wrap, polygon body</p> 	<p>Loads from measured data, dynamic loads from Simcenter 3D motion, mapped dynamic loads electro-magnetics, enforced vibration loads</p> 	<p>Model reduction techniques -modal, super-elements, FRFs</p>  <table border="1"> <caption>Model Reduction Performance</caption> <thead> <tr> <th>Number of Processors</th> <th>Minutes</th> </tr> </thead> <tbody> <tr> <td>4</td> <td>~350</td> </tr> <tr> <td>16</td> <td>~200</td> </tr> <tr> <td>32</td> <td>~150</td> </tr> <tr> <td>64</td> <td>~100</td> </tr> <tr> <td>128</td> <td>~75</td> </tr> <tr> <td>512</td> <td>~50</td> </tr> </tbody> </table>	Number of Processors	Minutes	4	~350	16	~200	32	~150	64	~100	128	~75	512	~50	<p>Modal, grid path, panel and structural model contribution, energy contributions, radiated power</p> 
Number of Processors	Minutes																				
4	~350																				
16	~200																				
32	~150																				
64	~100																				
128	~75																				
512	~50																				

What-if, optimization, feedback to designer

NVH and rotor dynamics

Dedicated interactive and solver solutions are available to support industry workflows for NVH and the dynamics of rotating machinery.

Uniquely combine real-world test data in the simulation

Using Simcenter 3D for structural dynamics solutions enables you to implement a distinctive hybrid simulation approach to leverage measured data as a component representation in a system-level finite element (FE) model, or to apply real-life loading to accurately and robustly accelerate the engineering process.

Increasing confidence in dynamic FE models

An integral part of making product engineering decisions is having confidence in the simulation models so you can accurately predict reality. Correlation solutions allow you to validate and improve the dynamic behavior of simulation models from physical test data.

Providing a platform for multidiscipline simulation

The Simcenter 3D structural dynamics solution is part of a larger, integrated multidiscipline simulation environment with the Simcenter 3D Engineering Desktop at the core for centralized pre-/postprocessing for all Simcenter 3D solutions. This integrated environment helps you to achieve faster CAE processes and streamline multidiscipline simulations that integrate dynamics and other disciplines like computing dynamic loads from motion, flow or electromagnetics solution.

Industry applications

Since most systems are subjected to loading that is dynamic in nature at some point in the lifecycle, understanding the dynamic behavior of structures is an important topic in many fields. Simcenter 3D provides a complete solution to predict dynamic behavior, be it for a component, subsystem or the complete system.

Automotive and transportation

NVH performance strongly impacts the driving experience and perception of quality. Simcenter 3D offers integrated tools and solvers to predict NVH characteristics and analyze the root cause of noise and vibration problems.

Aerospace and defense

Simcenter 3D helps you identify the structural weaknesses of a given design and optimize the vibration and dynamic performance of aeronautical structures subjected to dynamic loading. Dedicated solutions for rotor dynamics help you assess the performance of aero-engines to avoid instabilities.

Industrial machinery

Machines that excessively vibrate during operation directly impact the quality of the manufactured product. Simcenter 3D delivers insights into the possible cause of machine vibrations, including rotating machinery.

Electronics and consumer goods

Simcenter 3D helps predict the dynamic characteristics of electronics and consumer goods to avoid excessive vibrations and stresses, which could result in fatigue or catastrophic failure.

Marine

With an increasing demand for faster and lightweight ships, design engineers can rely on Simcenter 3D to predict the response of the overall structure and its individual components that are subjected to wave and current actions.

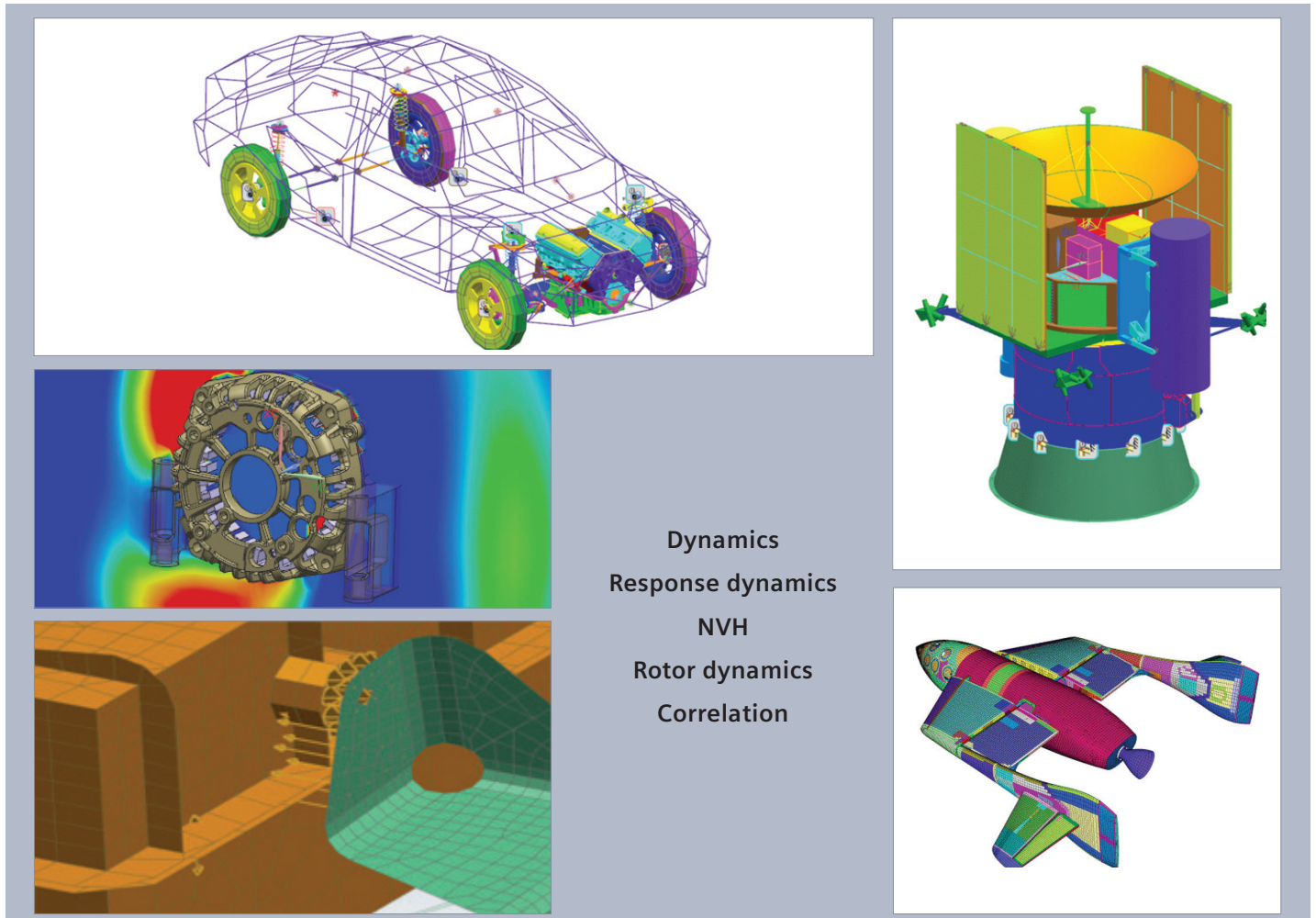

Dynamics
 Response dynamics
 NVH
 Rotor dynamics
 Correlation

Simcenter 3D

Response Dynamics

Simcenter 3D Response Dynamics software is an integrated solution that makes dynamic analysis more accessible and efficient for the analyst. It allows you to predict the forced response of structural systems under various loading conditions in a single graphical user environment, thereby eliminating the complexity of setting up and launching analysis and providing rapid insight into dynamic behavior. Analysis information can then be used to perform design studies to enhance the new product development process and confirm the quality of designs prior to physical prototyping and production.

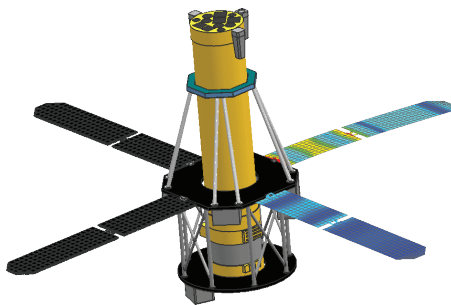
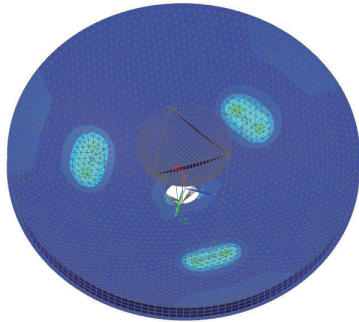

Module benefits

- Gain rapid insight into the dynamic response of structural systems
- Quickly generate and view results graphically
- Leverage all capabilities of Simcenter 3D to make quick design changes and provide rapid feedback on dynamic performance

Key features

- Predict modal response for transient, frequency (harmonic), random vibrations, shock spectrum, dynamic design analysis method (DDAM)(ship's shock loads) and quasi-static loads
- Efficiently calculate responses using a modal formulation starting from a priori solved set of Simcenter Nastran mode shapes
- Import, generate and edit the excitation information from computer-aided engineering (CAE) analysis and test data, including force, enforced motion and distributed loads (for example, dynamic pressure)
- Seamlessly interface analytical models with measured test data for instance-measured accelerations used for base-excitation loading
- Best-in-class random and sine base excitation events that handle real-world models with unparalleled performance and accuracy

Simcenter 3D

Noise and Vibration Modeling

Simcenter 3D Noise and Vibration Modeling offers a comprehensive set of noise and vibration pre/post capabilities addressing your need to build, understand, evaluate and optimize the noise and vibration performance of complete system and assembly models.

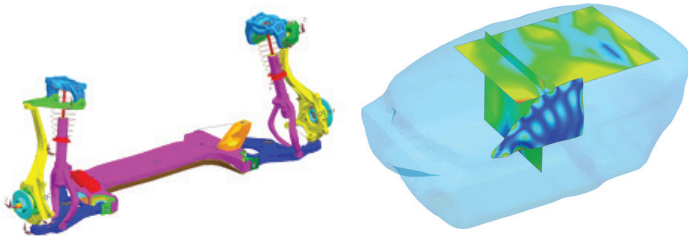
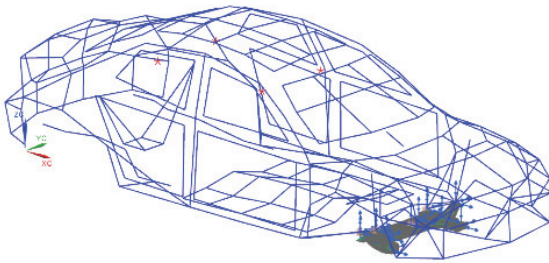
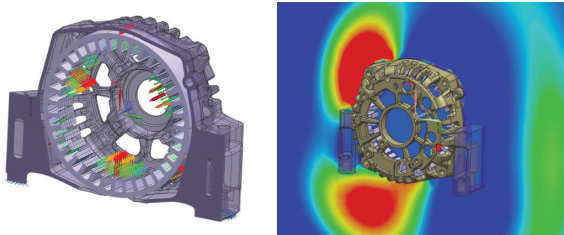

Module benefits

- Gain valuable insight into the noise and vibration performance of your design
- Use data from measurements and previous simulations to create relevant load cases
- Use dynamically equivalent, reduced component representations in your assembly model to speed up response analysis

Key features

- Intuitive noise and vibration diagnostics with support from modal, grid, panel, energy and path-contribution analysis
- Map test data and predecessor simulation data – multibody, electromagnetics (EM), computational fluid dynamics (CFD) – onto the vibro-acoustic simulation model, including time-to-frequency domain conversion for obtaining realistic loads
- Include frequency response function (FRF) and modal representations for structural components in assembly context using either simulation or test data
- Include acoustic transfer vectors (ATV) or vibroacoustic transfer vectors (VATV) representations for acoustic or vibro-acoustic components, which are re-usable for multi-load case scenarios for powertrain noise or cabin wind noise

Simcenter 3D Load Identification

Operational loads or vibrations are very important for accurate response prediction but are often impossible or difficult to measure directly. Simcenter 3D Load Identification enables you to compute dynamics loadings of a structure for dynamics or acoustics. You can compute acoustic loads as well as structural loads.

Simcenter 3D Load Identification offers two ways of identifying the operational forces from measured data, either by a direct stiffness method or by an inverse matrix method. Using the direct stiffness approach, the relative displacement (or velocity or acceleration) from the input vibration data and input frequency response functions (FRFs) are used to compute the forces at node locations on your finite element model (FEM). The inverse matrix method allows you to compute an estimate of the operating loads, based on operational measurements, such as accelerations and measured FRFs.

Additionally, Simcenter 3D Load Identification can also be applied to acoustics applications. You can use a modal expansion solution to create enriched vibration results on a full FE model based on measured vibrations in only a few points. Or you can derive structural surface vibrations through inverse numerical acoustics, where measured pressure responses near the structure are used together with acoustic transfer vectors (ATVs) to identify the full surface vibrations. The obtained vibration field can then be used further for acoustic radiation analysis.

Test



Module benefits

- Determine operational forces or vibrations which is difficult or impossible to measure directly
- Determine acoustic volumetric source strength from acoustic pressure
- Get more realistic simulation by applying more accurate loading
- Combine measured loading data with FE simulations

Key features

- Mount method to estimate mount forces by combining operational vibration data at each side of the mount and mount stiffness data
- Inverse matrix method by combination of operational measurements and transfer functions
- Based on all measured data or a combination of operation measurements and simulation data
- Straightforward application and reuse of the identified forces, vibrations and acoustic source strength to the simulation model

Mount stiffness method

- Operational vibrations on both ends of the mounts are measured
- Mount stiffness FRFs measured in lab



$$F(\omega) = K(\omega)[X_s(\omega) - X_t(\omega)]$$

Inverse matrix method

- Operational vibrations or acoustic pressures are measured
- FRFs measured in lab

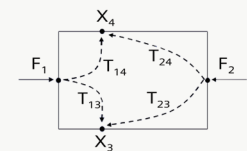

$$\begin{bmatrix} F_1 \\ F_2 \end{bmatrix} = \begin{bmatrix} T_{13} & T_{23} \\ T_{14} & T_{24} \end{bmatrix}^{-1} \begin{bmatrix} X_3 \\ X_4 \end{bmatrix}$$

Simcenter 3D

Noise and Vibration Response

The Simcenter 3D Noise and Vibration Response product provides users with the capability to perform modal-based forced response, FRF-based forced response and FRF synthesis to gain insight in the vibration or vibro-acoustic performance of a system. It is an alternative for users who have structural solvers from third party or for users who cannot subscribe to Simcenter Nastran.

For example, modal-based forced response is particularly useful in several scenarios that start from ANSYS or ABAQUS modes, or from measured modes. One can for example use the Simcenter 3D Noise and Vibration Forced Response product to compute surface vibration results which can subsequently be used in an analysis to predict acoustic radiation.

Another example is the embedded FRF-based forced response solver which provides a convenient and fast way to compute structural or vibro-acoustic response of a system that is described by simulated or measured FRFs under operational loading. This can be followed by TPA analysis using Simcenter 3D Noise & Vibration Modeling.

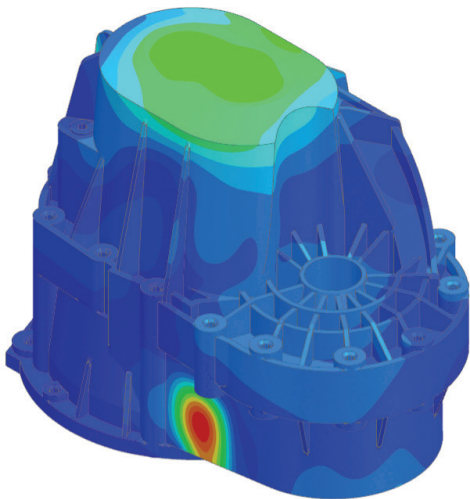

Gear box vibration response computed from Simcenter 3D Noise and Vibration Forced Response.

Module benefits

- Dedicated modal- and FRF-based forced response solvers in support of NVH and Acoustics scenarios.
- Enabling users to perform forced response without access to a full structural solver such as Nastran
- Quickly compute FRFs from measured or simulated modes for use in NVH or as reduced FRF representation of a component in an assembly or for use in correlation

Key features

- The FRF-based forced response solver provides a convenient and fast way to compute the structural or vibro-acoustic response of a system described by simulated or measured Frequency Response Functions (FRFs) under operational loading
- The Modal-based forced response solver provides a convenient way to compute the structural (vibration) response of a system described by a set of modes under operational loading
- The FRF Synthesis Solver allows to compute FRFs starting from a set of measured or simulated modes

Simcenter 3D Assembly Composer

The Simcenter 3D Assembly Composer is a streamlined product to create system level FE models from system FE models.

It is a very practical tool for defining hybrid NVH models by combining FE subsystems with reduced (test/FE) components in the form of mode sets for instance. It can also be used as a streamlined solution to define full vehicle NVH models starting from subassembly models (BIW, door, suspension...).

The product offers an interactive network display to define the topology of the system level assembly by defining components, connectivity information and optionally lumped mass trim information. Once the assembly layout is defined, the AFEM assembly is automatically created in Simcenter 3D and syncs it with the network display of the Simcenter 3D Assembly Composer. All typical connections between full vehicle subsystems are available and the modeling is done for Simcenter Nastran.

Module benefits

- Increase productivity and speed up system level (e.g. full vehicle NVH) creation time
- Decrease human error by capturing assembly topology in layout files
- Take out the complexity of full vehicle assembly model creation
- Rerun easily in case of component changes

Key features

- Interactive network display to define full vehicle topology starting from subsystem FE models
- All typical full vehicle connections are supported (bolt, bushing, weatherstrip/sealing,...)
- Support of lumped mass trimming
- Automatic assembly from the defined full vehicle topology
- Integrated checking functionality
- Support of reduced subassembly representations (measured or FE), for instance by modal representation
- Automatic synchronization between Simcenter 3D NVH Composer and resulting Simcenter 3D assembly

Simcenter 3D FE Model Correlation

Simcenter 3D FE Model Correlation software enables you to quantitatively and qualitatively compare simulation and test results, as well as two different simulations. It provides the tools needed to geometrically align the models, pair the shapes from both solutions, view mode and operational shapes and frequency response functions and calculate/display correlation metrics.

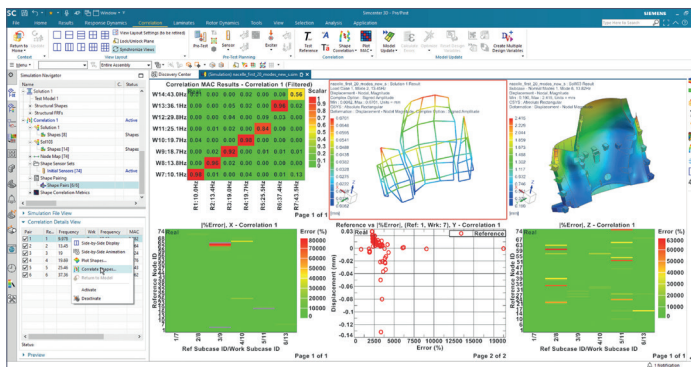

Module benefits

- Validate the accuracy of the finite element model for structural, acoustic and vibro-acoustic dynamic analysis
- Determine sensor and exciter locations before performing physical modal tests
- Increase productivity by enabling model validation in the same environment as used for model creation and analysis

Key features

- Supports Simcenter Nastran software, Abaqus, ANSYS and MSC Nastran results
- Test solution import using universal files or Simcenter Testlab™ software files
- Pretest planning including sensor and exciter placement, creation of automatic or manual visualization wireframes, as well as automatic face normal detection
- Intuitive and powerful test model alignment
- Shape correlation criteria: MAC, X-Orthogonality, frequency and error
- Modal, operational and static shapes
- Automatic and manual shape pairing
- Interactive matrix and mode-shape displays
- Frequency response function assurance criterion (FRAC)
- Interactive FRAC and FRF overlay plots
- Node mapping based on proximity, labels or names as well as manual methods

Simcenter 3D FE Model Updating

Simcenter 3D FE Model Updating software is an advanced correlation tool designed to automatically update FE models to match real-life test data or other FE model results. The tool is fully integrated within Simcenter 3D Engineering Desktop, making the updating process efficient, intuitive and productive.

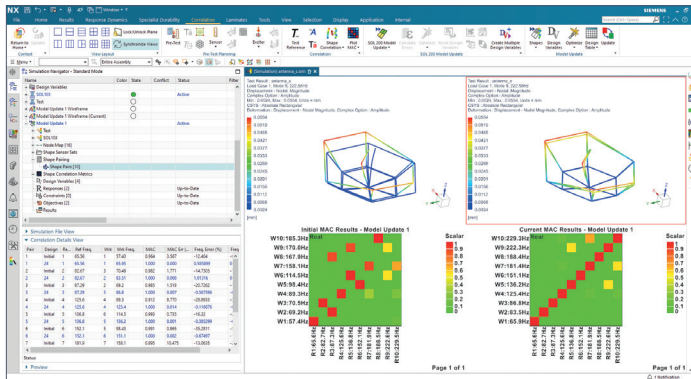

Module benefits

- Improve accuracy and increase confidence in your FE models
- Increase productivity by performing model updating in the same environment used for model creation and analysis
- Provide quick sensitivity-based approach

Key features

- Optimization targets: modal frequencies and mode shapes
- Mode shape correlation criteria: MAC, X-Ortho
- Automatic and manual mode pairing options
- Simultaneously update multiple configurations of the same FEM
- Automatic FEM update that can be easily cascaded to all simulations
- Automatic and manual design variable management
- Automatic generation of multiple design variables
- Support material and physical property design variables such as beam section areas, shell or laminate ply thickness and Young's modulus
- Simcenter Nastran or MSC Nastran SOL 200 licenses not required

Simcenter 3D Rotor Modeling

Simcenter 3D Rotor Modeling is a comprehensive environment for pre- and postprocessing models used for rotor dynamics analysis using the Simcenter Nastran Rotor solver. Simcenter 3D Rotor Modeling guides you through the typical workflow of defining your rotors, bearings, and assemblies and then helps you set up the simulation solution parameters. Simcenter 3D Rotor Modeling also takes full advantage core Simcenter 3D Engineering Desktop capabilities to easily edit model geometry and keep your rotor simulation models in-synch with your design. The rotor modeling environment is where you also efficiently evaluate the results of your simulations visually and graphically so you can easily determine if your rotor designs are performing to your requirements.

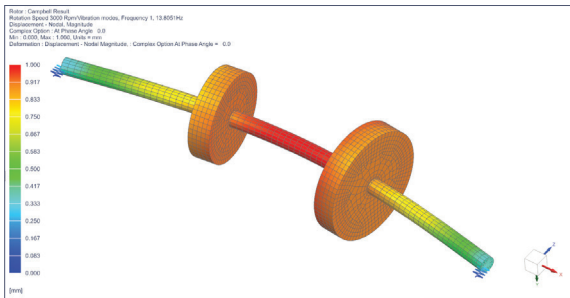
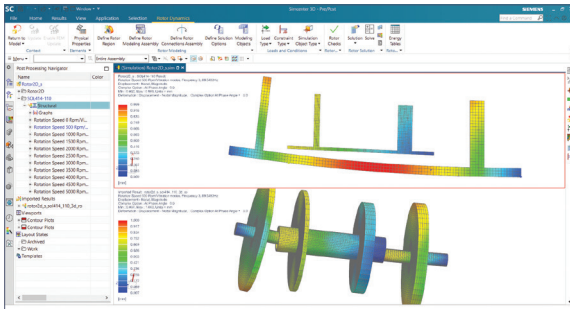

Module benefits

- An integrated solution that helps you rapidly solve and iterate on your rotor designs to achieve optimal performance
- Understand how your rotor performs in unbalance analysis, predict a blade-out event, and determine critical speeds
- Guides you through a complete end-to-end workflow from rotor and bearing modeling, solution setup, and results visualization

Key features

- Addresses a wide range of loading scenarios, like unbalanced loads, misalignment, time-dependent forces and more
- Efficient modeling techniques and model reduction like Fourier multi-harmonic elements or cyclic symmetry or superelement
- Wide range of post processing capabilities for Campbell diagram, energies distributions, modes and deformed shapes animations, orbit plots, recombination of results in 3D
- Model the rotors and stator parts of the assembly by different modeling approaches using efficient model reduction and connect the components by a collection of linking devices

Simcenter Nastran Dynamic Response

Simcenter Nastran Dynamic Response software is the core solver for dynamic finite element analysis (FEA). It enables the Harmonic response analysis of a component or assembly subject to time- or frequency-varying excitations. Assessing dynamic response of a structure under different operating conditions is critical to industries such as automotive, aerospace, consumer products and other sectors that rely on electronic devices. It is possible to perform numerous what-if studies by virtually investigating the product's performance in various dynamic operating conditions by using the rich analysis tool set supported by Simcenter Nastran Dynamic Response.

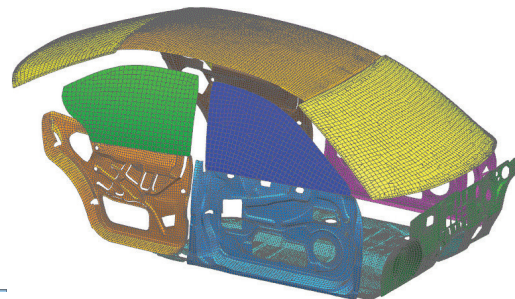
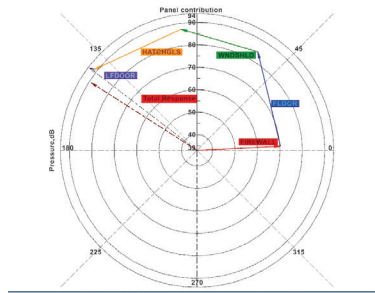
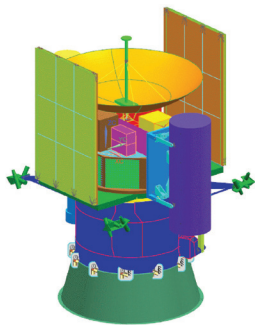
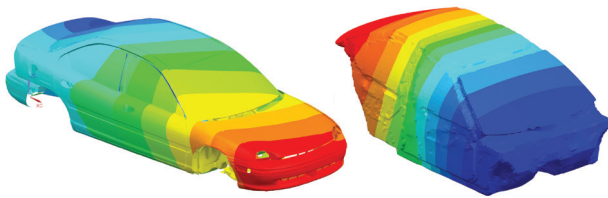

Module benefits

- Assess dynamic performance of your physical model
- Apply to all applications, industries and model sizes
- Save time and cost compared to physical build-test-break cycles

Key features

- Comprehensive dynamic response set. Supports frequency, transient and random response
- Includes a list of eigenvalue solvers such as Lanczos, Householder, Hessenberg, etc.
- Supports numerous types of dynamic loading in time and frequency domain
- Fast modal frequency response solvers (FFRS) applicable to large models and large number of modes - especially when the modes are coupled due to structural and viscous damping

Simcenter Nastran Advanced Dynamics bundle

Simcenter Nastran Advanced Dynamics is a cost-effective bundle that provides a rich set of functionality for advanced dynamic analysis. It allows the user to produce reduced order models and use them in a system analysis. The reduced order model can be a modal model, an external superelement or an FRF representation. The advanced dynamic analysis product also features RDMODES, which is a fast eigenvalue solver for large models with many modes. Coupled with fast frequency response, large models with many modes and many frequencies can now be solved rather quickly. The advanced dynamics product also offers high performance computing (HPC) capability via distributed computing or DMP.

The advanced dynamics product also includes direct matrix abstraction program (DMAP). This product is the gateway to openness in Nastran. Users can alter the regular solutions and tailor it to meet their requirements.

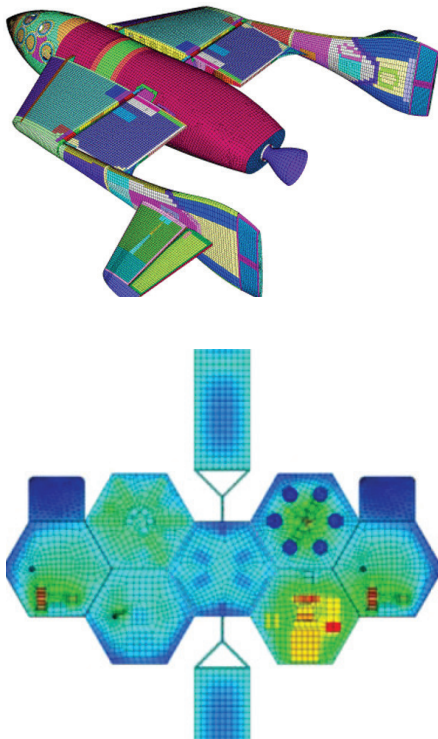

Module benefits

- Use cost-effective bundle to perform comprehensive dynamic analysis and accelerate product time-to-market
- Build system assembly models using a hybrid assembly of components based on finite elements and test measurements or reduced order models

Key features

- Includes all capabilities of Simcenter Nastran Dynamic Response
- Includes Nastran superelement representation and Simcenter Nastran FRF representation
- Computes the forced response of a product subject to time or frequency varying excitations
- Represents a component in the form of frequency response function, an alternate form of matrix representation of a component
- Large models consisting of large number of modes can be efficiently solved using recursive domain normal modes (RDMODES)
- Model slosh behavior - that is, predict slosh modes and hydro-elastic modes
- Analyze structural models in the presence of an airstream using aeroelastic analysis
- Modify and adapt out-of-the-box (OOTB) solution sequences using DMAP
- Perform advanced "Response Spectra" analysis
- Perform analysis with incompressible fluid in tanks and account for sloshing
- Perform DDAM analysis

Simcenter Nastran DMP

Simcenter Nastran DMP facilitates a significant reduction in computing time by using multiple processors and computing resources. Simcenter Nastran DMP enables a higher level of parallelism and provides better scalability than shared memory processing (SMP).

Module benefits

- Rapidly solve complex large problems
- Use the DMP solution to solve large problems significantly faster

Key features

- Simcenter Nastran has many options for partitioning solution domains, such as geometric, frequency, hierarchic, load and RDMODES
- DMP can also be operated on a single node that has multiple processors
- Supported dynamic solution types are modal and direct frequency response, eigenvalue computation and modal transient

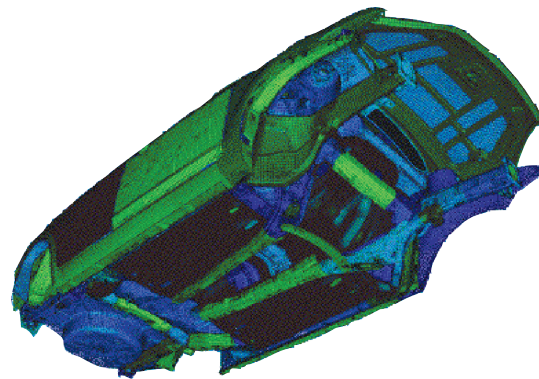
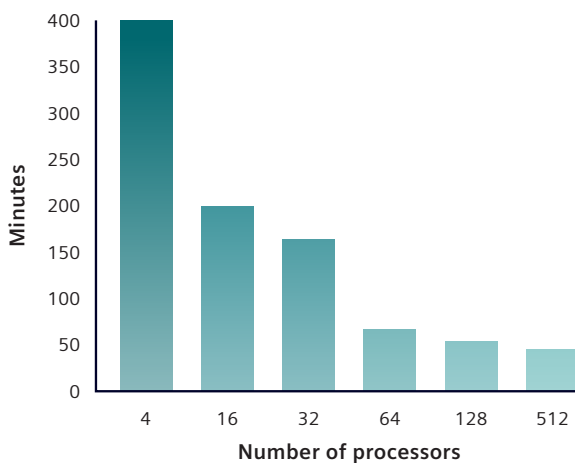

Simcenter Nastran Rotor

Simcenter Nastran Rotor is the solver for simulating a variety of rotor dynamics analyses for mechanical engineers studying industrial rotating machinery applications, like gas turbines, pumps and more. Understanding critical operational speeds and predicting survivability of rotating systems is a critical, yet challenging task. Simcenter Nastran helps you determine these critical criteria by accounting for gyroscopic effects and centrifugal loads in a wide range of situations.

Pre- and postprocessing for Simcenter Nastran Rotor is done using the Simcenter 3D Rotor Modeling product.

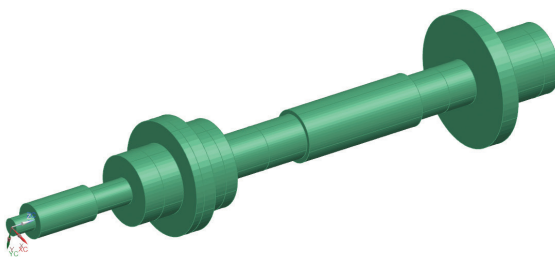
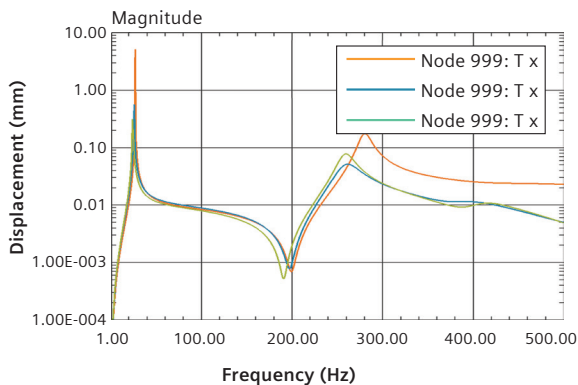

Module benefits

- Simulate and assess rotor dynamics performance of your physical model
- Compute critical speeds and find whirl frequencies to avoid catastrophic failure of rotating machines

- Evaluate simple models with linear bearings to complex systems with nonlinear connections
- Breadth of analysis capabilities to cover a wide range of loading scenarios
- Reduce modeling time and speed solution time through modeling techniques like Fourier multiharmonic elements or cyclic symmetry or superelements
- Save time and cost compared to physical build-try break cycles

Key features

- Compute Campbell diagram, with critical speeds, complex modes, and whirl frequencies
- Simulate using frequency-dependent (synchronous or asynchronous, modal or direct, one or multiple harmonics) or time-dependent excitation or maneuvers loads
- Account for geometric nonlinearities of connection elements in the simulation
- Supports typical rotor dynamics scenario like unbalance loading or blade out analysis or misalignment
- Account for geometric nonlinearities of connection elements in the simulation
- Analyze symmetric and asymmetric rotor models, as well as multiple rotors with different rotation speeds
- Include differential stiffness to compute centrifugal stiffening/softening effects
- Solve the model in the fixed or rotating coordinate reference system
- Enable SMP/DMP in combination with Simcenter Nastran DMP

Capabilities chart

General capabilities	Specific capabilities	Simcenter 3D Response Dynamics	Simcenter 3D Noise and Vibration Modeling	Simcenter 3D Load Identification	Simcenter 3D Noise and Vibration Forced Response	Simcenter 3D Assembly Composer	Simcenter 3D FE Model Correlation	Simcenter 3D FE Model Updating	Simcenter 3D Rotor Modeling	Simcenter Nastran Dynamic Response	Simcenter Nastran Advanced Dynamics bundle	Simcenter Nastran DMP	Simcenter Nastran Rotor
		Structural dynamics											
Structural linear dynamics	Modal transient response	•								•	•		
	Modal frequency response	•			•					•	•		
	Direct transient response									•	•		
	Direct frequency response									•	•		
	Cyclic direct frequency response									•	•		
	Complex modal analysis									•	•		
	Shock spectrum	•								•	•		
	Random vibration	•								•	•		
	Dynamic design analysis method (DDAM)	•								•	•		
	FRF based forced response										•	•	
	Incompressible fluid effects and sloshing										•		
Advanced linear dynamic analysis	Superelements										•		
	Coupled fluid-structure (vibro-acoustic) analysis									•	•		
	Frequency transfer functions (FRF)				•						•		
	Recursive domain normal modes (RDMODES)										•		
	Fast frequency response (FASTFR)									•	•		
	Direct matrix abstraction programming (DMAP)										•		
	Aero-elasticity										•		
	Incompressible fluid effects and sloshing										•		
Parallel processing	Shared memory parallel (SMP)	•			•					•	•	•	
	Distributed memory parallel (DMP)										•	•	
	SMP/DMP for Rotor										•	•	
Noise and vibration (NVH)													
NVH model creation	2D full vehicle topology definition from subassemblies					•							
	Full vehicle assembly automation					•							
	Bolt					•							
	Spring and bushing					•							
	Weatherstrip/sealing					•							

General capabilities	Specific capabilities	Simcenter 3D Response Dynamics	Simcenter 3D Noise and Vibration Modeling	Simcenter 3D Load Identification	Simcenter 3D Noise and Vibration Forced Response	Simcenter 3D Assembly Composer	Simcenter 3D FE Model Correlation	Simcenter 3D FE Model Updating	Simcenter 3D Rotor Modeling	Simcenter Nastran Dynamic Response	Simcenter Nastran Advanced Dynamics bundle	Simcenter Nastran DMP	Simcenter Nastran Rotor
NVH model creation <i>(continued)</i>	Seam weld					•							
	Kinematic (e.g. latch and bumpstop)					•							
	Lumped mass trimming					•							
NVH post-processing	Modal contribution		•										
	Panel/grid contribution		•										
	Path contribution		•										
	Energy contribution		•										
Noise and vibration (NVH) <i>(continued)</i>													
System level NVH (hybrid)	Modal representations (modal coupling preprocessing)		•										
	FRF representations (FRF coupling preprocessing)		•										
	FRF analysis case		•										
Additional NVH	Transfer path analysis		•										
	Load identification analysis (mount method, inverse force)			•									
Rotor dynamics													
Rotor models	1D (line models), 3D models												•
	2D multi-harmonics models												•
	Mixed modeling representation												•
	Multiple rotors												•
	Cyclic symmetry												•
Super-elements	Superelement for the nonrotating and rotating parts												•
Bearing models	Springs, dampers, bushings, bearings												•
	Hydrodynamic, roller ball bearings, squeeze film dampers												•
	Nonlinear bushings and bushing with rupture law												•
	User proprietary bearings												•
Pre-processing	Rotor models preparation								•				
	Rotor Dynamic solution setup								•				
Rotor dynamic solutions	Campbell diagram and stability analysis												•
	Modal analysis (normal/complex)												•
	Harmonic response (direct/modal, synchronous/asynchronous, one or multiple frequencies)												•
	Linear/Nonlinear transient response												•
	Linear/Nonlinear static analysis												•

General capabilities	Specific capabilities	Simcenter 3D Response Dynamics	Simcenter 3D Noise and Vibration Modeling	Simcenter 3D Load Identification	Simcenter 3D Noise and Vibration Forced Response	Simcenter 3D Assembly Composer	Simcenter 3D FE Model Correlation	Simcenter 3D FE Model Updating	Simcenter 3D Rotor Modeling	Simcenter Nastran Dynamic Response	Simcenter Nastran Advanced Dynamics bundle	Simcenter Nastran DMP	Simcenter Nastran Rotor
Rotor dynamic solutions <i>(continued)</i>	Unbalance analysis												•
	Blade out analysis												•
	Misalignment analysis												•
	Thermal static bow												•
	Large rotation and large displacements												•
	Damping: viscous, structural, modal, hysteretic												•
	Rotating/fixed reference frame												•
Postprocessing <i>(continued)</i>	Campbell diagram, damping diagram, Nyquist diagrams								•				•
	Mode shapes visualisation and whirling animation								•				
	Recombine 3D results after 2D models analyses								•				•
	Recombine 3D results after cyclic symmetry computations								•				•
	Table of energies distribution								•				•
	Recover results after superelement computations								•				•
	Clearance consumption monitoring								•				•
Correlation													
Pretest and correlation	Pretest planning						•						
	Test model alignment and geometry mapping						•						
	Test-analysis, analysis-analysis correlation						•						
	Shape correlation: MAC, COMAC, error scatter, function and matrix						•						
	Modal correlation: X-orthogonality						•						
	Modal, operational, static structural shapes/acoustic mode shapes						•						
	FRF correlation: structural, acoustic and vibro-acoustic						•						
	Local coordinate systems						•						
	Shape pairing and visual comparison						•						
	Simcenter Testlab interface						•						
	Teamcenter interface						•						

General capabilities	Specific capabilities	Simcenter 3D Response Dynamics	Simcenter 3D Noise and Vibration Modeling	Simcenter 3D Load Identification	Simcenter 3D Noise and Vibration Forced Response	Simcenter 3D Assembly Composer	Simcenter 3D FE Model Correlation	Simcenter 3D FE Model Updating	Simcenter 3D Rotor Modeling	Simcenter Nastran Dynamic Response	Simcenter Nastran Advanced Dynamics bundle	Simcenter Nastran DMP	Simcenter Nastran Rotor
Model updating	Design variable definition							•					
	Dedicated DESOPT 200 - model update solution							•					
	Design variable sensitivities							•					
	Frequency, mode shape (MAC and X-orthogonality)							•					
	Embedded eigenvalue solver							•					
	Multiple optimization algorithms							•					
	FEM and SIM update							•					
	Model updating for Simcenter Nastran and MSC Nastran							•					
	Simultaneous update of multiple configurations							•					

Legend:

• = included in module

Note: Simcenter 3D Engineering Desktop is a minimum prerequisite for all Simcenter 3D products. Other dependency or prerequisites may apply for individual products.

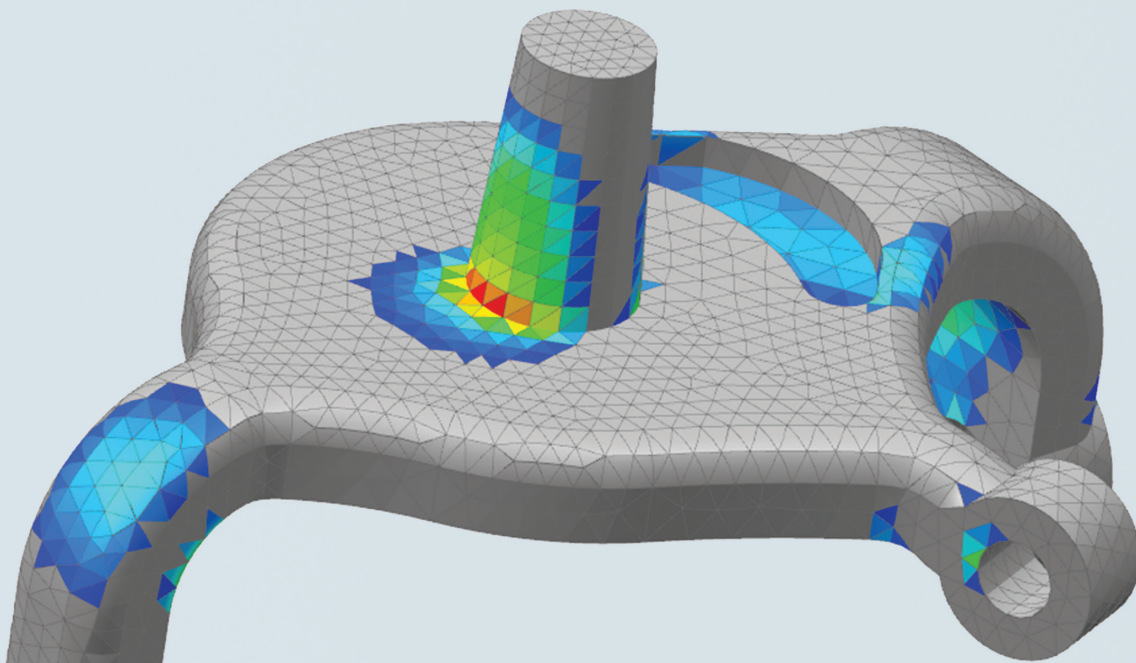

DIGITAL INDUSTRIES SOFTWARE

Simcenter 3D for strength and durability simulation

Enabling in-depth fatigue and lifing analysis

Solution benefits

Explore multiple design options and optimize your design for strength and fatigue performance

Perform fatigue life prediction analyses quickly

Get insightful and rapid feedback on critical durability areas

Simulate new materials and manufacturing processes, complex connections and welds

Predict loads on a system and component level

See immediately what your finite element results mean with respect to strength and durability

Simcenter™ 3D software offers a distinctive suite of tools to support strength and fatigue design in all stages of development. This includes easy-to-use wizards for strength and fatigue in the design phase; fatigue information on the current simulated part; detailed analysis of complex load scenarios, including weldments and connections; as well as new materials and manufacturing processes.

The best way to predict a product's strength and durability

Shorter development cycles and ever-increasing quality requirements have stretched the test-based durability approach to its limit. Evaluating and refining the durability performance by

simulation methods is the only valid alternative. The durability modules of Simcenter 3D give you access to state-of-the-art analysis methods, enabling engineers to interactively assign loads to a model. The solution permits efficient analysis of seam and spot welds as well as new methodologies for composite materials.



Durability

SIEMENS

[siemens.com/simcenter3d](https://www.siemens.com/simcenter3d)

Simcenter 3D

for strength and durability simulation

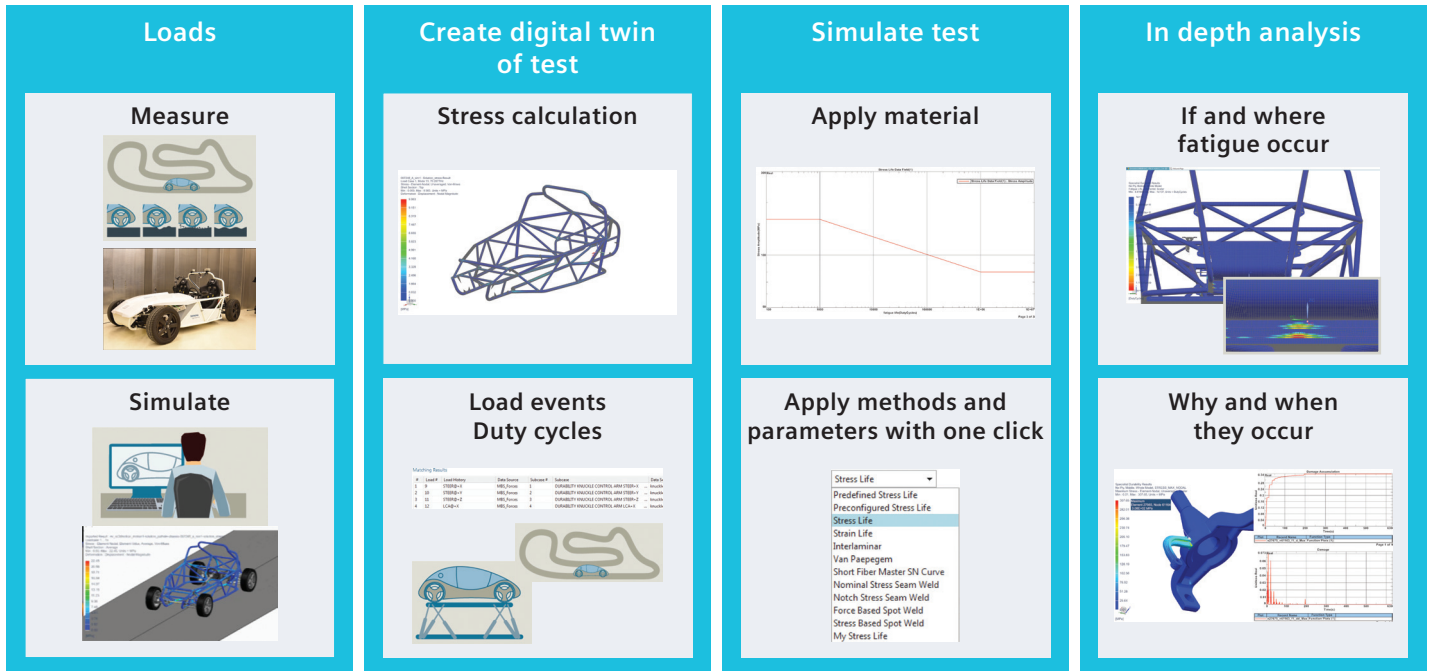

Eliminate over- or under-designed components

Analyze loads acting on the critical regions and improve the load flow from the application points that have the greatest influence on the critical areas. This leads to much better designs than reinforcing around the critical areas saving on weight and materials.

Enabling a more efficient and safe physical validation

Virtual test rig experiments facilitate the analysis of the impact of individual load events on component damage. Such analysis also permits the flexibility to define your specific load scenarios for each of the components, thereby saving testing time.

Include manufacturing and assembly aspects in durability analysis

New materials and manufacturing processes often have an important influence on fatigue behavior. With Simcenter 3D, one can take into account such manufacturing influences while performing durability analysis.

Design it right the first time

To perform fatigue analysis in an efficient way, durability modules provide access to:

- Test data such as loads used, test schedule definitions, etc.
- Simulation data, such as multibody results and finite element simulations of the digital twin
- State-of-the-art strength and fatigue simulation methods
- Fatigue-specific postprocessing

Providing a platform for multidiscipline simulation

The Simcenter 3D durability solution is part of a larger integrated multidiscipline simulation environment with the Simcenter 3D Engineering Desktop at its core. This centralized desktop environment provides all the pre/post-processing tools for all of the Simcenter 3D solutions. This integrated environment helps you to achieve faster CAE processes and streamline multidisciplined simulations. It integrates durability with disciplines such as stress and strain, and structural solutions. It can also perform load prediction using motion solutions of short or endless fiber composites that exhibit nonlinear behaviour, all while maintaining a tight integration with damage tolerant design.

Industry applications

Aerospace and defense

Simcenter 3D is used to predict lifing for mechanical systems like turbines, landing gears, control mechanisms, slat tracks and other critical assemblies. Local stress concentrations are identified based on all possible combinations of local load conditions to address durability problems long before prototypes are built. A wide range of methods can localize weak spots and assess fatigue life.

Automotive and transportation

Simcenter 3D is used to execute fatigue-life assessments on body frames, panels, cross-members, and door systems, as well as sunroofs, latches, and locking systems. The Simcenter 3D Durability module also enables a high degree of accuracy for specific seam and spot weld analyses. Advanced numerical durability predictions can be applied to engines, powertrain parts, engine brackets, gear box chain heels and exhaust lines.

Industrial machinery

In industrial applications, achieving cost efficiencies depends on critical parts that are typically subjected to large dynamic multiaxial load cases. Any metal component subjected to dynamic loading cycles can be efficiently optimized. Simcenter 3D Durability can be used to determine rotor base fatigue life in large rotating machines.

Medicine

Durability and full function is especially important for medical devices. Simcenter 3D Specialist Durability is used to avoid failures of critical systems.

Marine

Simcenter 3D Specialist Durability connection modeling allows you to have a digital twin for the kilometers of welds performed in ship structures. For high-end yachts with lots of composite materials, the Simcenter 3D Specialist Durability Composite Fatigue module facilitates state-of-the-art analysis.

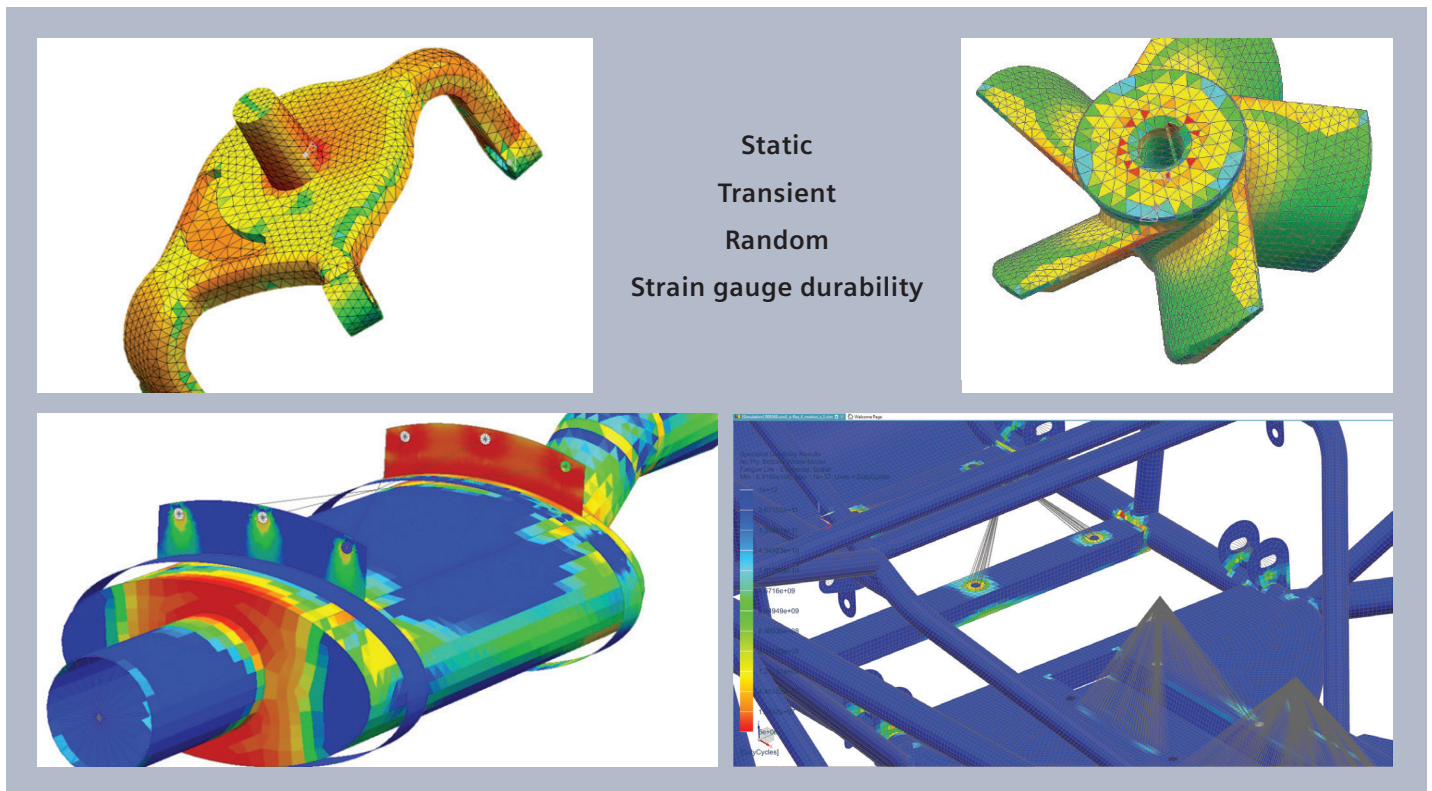

Simcenter 3D Durability wizard

Simcenter 3D Durability wizard is a simulation wizard for calculating the fatigue life of mechanical components subjected to cycles of loading. This solution is performed after users have calculated a stress state from static loading using a finite element (FE) solver. The durability algorithms in the wizard are based on the crack initiation method for fatigue analysis.

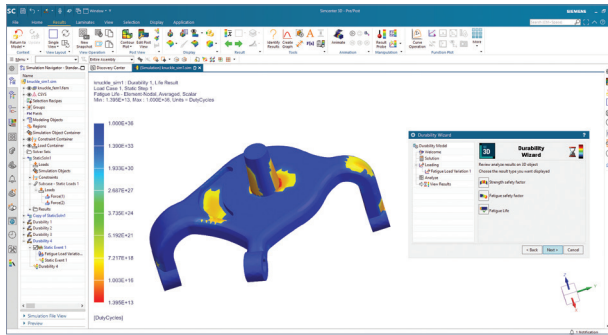

Durability 5			
Fatigue Load Variations			
4	Load Variation	Number of Cycles	Scaling Factor
5	Fatigue Load Variation 1		1
6			1.00000 Half Unit Cycle
Fatigue Analysis Options			
Evaluation Type			
Options			
Ultimate			
Von_Mises			
Number of Fatigue Duty Cycles: 1e+20			
Fatigue Safety Factors			
Fatigue Strength Factor: 1			
Fatigue Life			
Stress_Life			
Results			
Coordinate System			
Absolute Rectangular			
Number of LoadCases:			
1			
Load Case 1: Number of Iterations = 1			
Strength Safety Factor(Unitless)			
Fatigue Safety Factor(Unitless)			
Fatigue Life(DutyCycles)			
18	Iteration 1		
19	Max	7.67E+04	4.65E+03
20	Min	1.74E+01	4.11E-01
21			1.00E+36
21			2.39E+16

Module benefits

- Improves robustness by predicting the life of product designs and determining which design features are over- or under designed
- Reduces physical testing costs by allowing you to analyze product life in a virtual environment
- Accelerates product design by allowing designers to quickly perform what-if reanalysis of new designs
- Understand the impact of changes to product durability

Key features

- Use linear stress or strain results in static solutions with NX™ software stress wizard, Simcenter Nastran® software, MSC Nastran, Abaqus and ANSYS
- Define the cyclic loadings that define the duty cycle of the part over its lifetime
- Compute static safety factors, fatigue safety factors and fatigue life
- Available fatigue criterion: Smith-Watson-Topper, strain or stress life
- Display contour plots for strength safety factor, fatigue safety factor or fatigue life
- Prepare a technical durability report

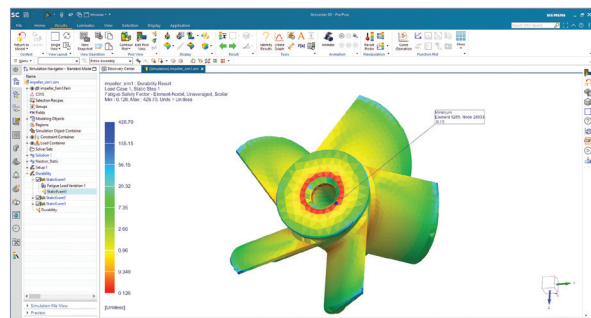

Simcenter 3D Specialist Durability Modeling

Simcenter 3D Specialist Durability Modeling provides a rich and intuitive tool set to prepare solutions, send them to the solver and postprocess durability results. It starts with the new strength and durability wizard and enables the setup of complex durability scenarios with many finite element and load history cases. Durability solutions may be configured using the provided parameters or configured to follow the standard procedures of the user.

Simcenter Specialist Durability starts with a standardized setup using a wizard then with just a few mouse clicks enhances the tests with all the state of the art lifeing and fatigue tools. A wide range of results are also included, from automated results plots in the wizard to detailed analysis of events, damage, remaining useable lifetime and more.

Module benefits

- Intuitive and flexible parameter-based setup
- Full range of analysis in one tool
- Quickly isolate fatigue-critical events, locations and load cases under complex duty cycles
- Understand the cause of fatigue problems

Key features

- Automated use of finite element, loads prediction, and motion results
- Parameter-driven analysis templates, solver profiles and durability simulation objects
- Direct component-load importing from prototype measurements smart virtual sensors or Simcenter 3D multibody simulation and third-party, time-data formats
- Direct access to Simcenter 3D materials databases, dedicated tools to create and access durability data, and fatigue material databases
- Integration with Simcenter Testlab™ software load-data processing tools for durability load-case selection
- Assign complex duty cycles to assemblies and their connections, including seam and spot welds
- Dedicated 2D and 3D postprocessing scenarios for application specific plots

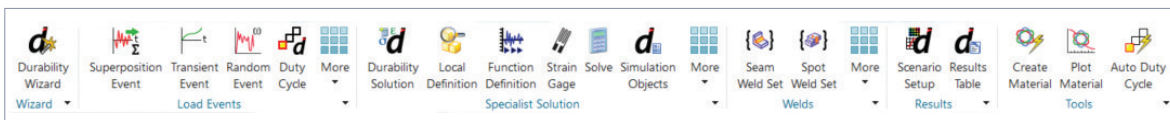
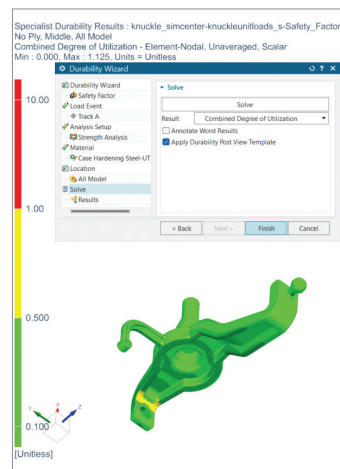
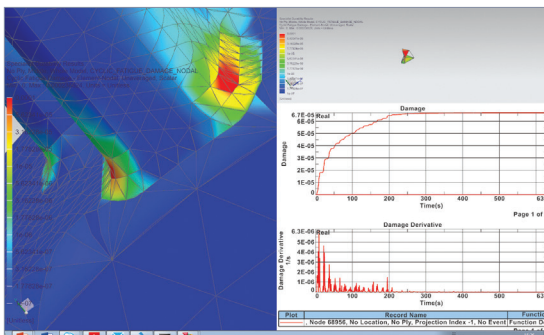

Simcenter 3D

Specialist Durability solver

The Simcenter 3D Specialist Durability solver is the modern open release of the well known FALANCS solver, used for strength, fatigue, and lifing analysis. It automatically extracts the load and temperature cycles from any load event. It may be run on the same computer or independently in batch mode including parallel process. It provides all standard durability methodologies but may easily be extended with any fatigue methodology due to unique openness via user-defined fatigue methods.

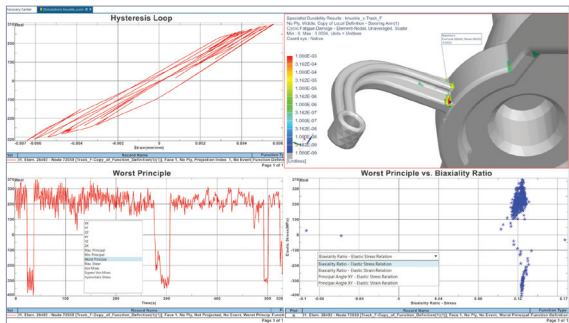
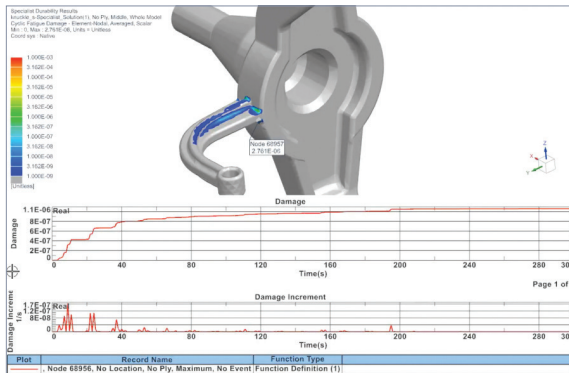

Module benefits

- Reduce fatigue analysis time
- Quick and accurate fatigue-life predictions based on realistic loading conditions
- Explore multiple design options and optimize the design for fatigue performance

Key features

- Industry standard fatigue-life solver with proven accuracy and speed
- Parallel processing enabled with the standard license
- All industry standard methods
- New and unique user defined methods interface
- Batch processing
- Easily extensible by user defined methods

Simcenter 3D

Specialist Durability Composite Fatigue

Simcenter 3D Specialist Durability Composite Fatigue provides a unique methodology for analyzing short and continuous-fiber composites. It can incorporate stiffness reduction and stress redistribution during the fatigue life of composites under complex load situations. New technologies reduce the effort it takes to test for parametrization of the methods.

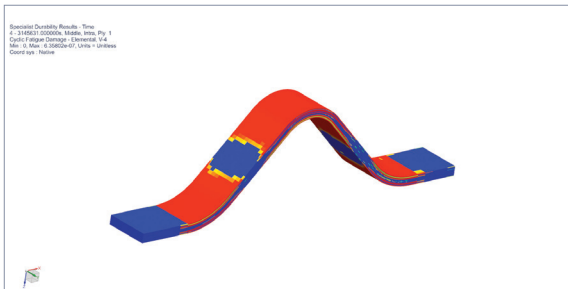
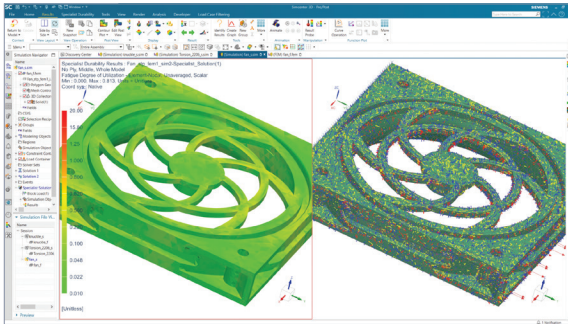

Module benefits

- Know the real progressive damage behavior of your composite material
- Allows damage-tolerant design
- Ability to predict fatigue damage to composite material
- Defined parameter identification processes available

Key features

- Unique workflow that enables stiffness reduction and stress redistribution
- Variable amplitude and multiaxial loads
- Ply-based fatigue behavior modeled without the need for full stacking tests
- Master SN-curve approach for arbitrary short-fiber orientations
- Intra- and Interlaminar methods for continuous-fiber composites
- User-defined methods, including stiffness reduction and stress redistribution

Simcenter 3D

Specialist Durability for Connections

Simcenter 3D Specialist Durability for connections allows you to set up and conduct special spot weld and seam weld analysis runs. Welds are taken from connections modeled in Simcenter 3D, defined in the xMCF format, or detected in existing meshes. The load setup and analysis are conducted with the same tools from Simcenter 3D Specialist Durability Modeling and may even be mixed in the same analysis case.

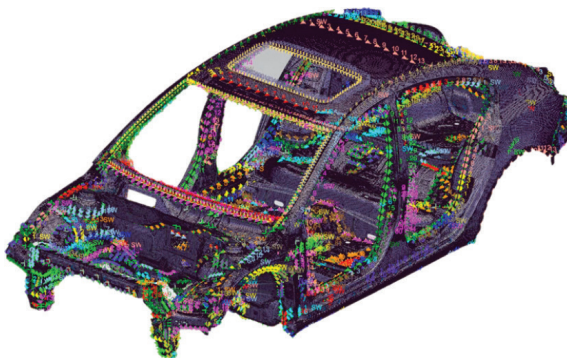
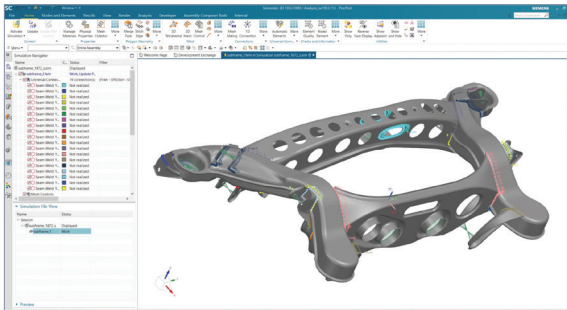
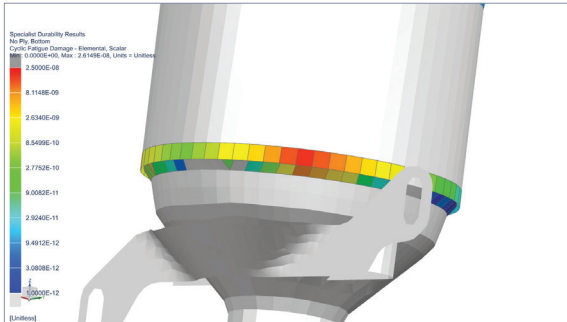

Module benefits

- Comprehensive software to predict fatigue of seam and spot welds under arbitrary loading conditions
- Provides accurate predictions of seam weld fatigue life without remodelling
- Increases engineers' throughput by enabling automatic detection of weld topologies
- Powerful software to handle welded assemblies irrespective of size and number of welds
- Efficiently handles both traditional approaches and most accurate approaches on the same model
- Validate more weld variants and their fatigue life within shorter development cycles
- Understand and improve fatigue testing for seamwelded assemblies

Key features

- Innovatively designed algorithms: Automatic detection of welds and weld geometry from FE models and groups based on joint types, penetration grade and sheet thickness
- Support industry typical FE connection modeling for seam and spot welds
- Handles all load cases: transient, random, harmonic, proportional and non-proportional and schedules
- Special tools for seam welds: Mesh independent notch stress method (R1MS, R03MS, R005MS), including notch effects (effective notch stress method) using the microstructural length p^*
- User-defined methodologies can access all weld data

Capabilities chart

General capabilities	Specific capabilities	Simcenter 3D Durability Wizard	Simcenter 3D Specialist Durability Modeling	Simcenter 3D Specialist Durability solver	Simcenter 3D Specialist Durability Composite Fatigue	Simcenter 3D Specialist Durability for Connections
Loads and stresses	Loads from Simcenter Testlab		•	•	•	•
	Loads from industry test formats (IST, MSC, EDAS,...)		•	•	•	•
	Loads from Simcenter 3D Motion		•	•	•	•
	Loads from Simcenter 3D Smart Virtual Sensing		•	•	•	•
	Finite element results (Simcenter Nastran, Simcenter Samcef, ABAQUS, ANSYS, universal format)	•	•	•	•	•
	Non-Linear stresses and/or strains		•	•	•	
	Block load events	•	•	•	•	•
	Superposition events (unlimited number of loadcases, automatic matching)		•	•	•	•
	Transient events (editor to select increments, change order, invert ordering)		•	•	•	•
	Pre-stress and static load cases		•	•	•	•
	Flexible event (directly analyse Simcenter3D Motion Flexible Body)		•	•	•	•
	Smart virtual sensing specialist durability event		•	•	•	•
	Duty cycle events		•	•	•	•
	Duty cycles from spreadsheets		•			
	Materials	Simcenter 3D material database	•	•	•	•
Generation of material set based on existing material data (UML, universal slope, ...)			•			
Material individually assigned to selection and groups		•	•			
Weld standard data (IIW, Eurocode, BS, ...)			•			
Durability databases			•			
Setup	Directly from finite element calculation	•	•			
	Inherit or overwrite materials	•	•			
	Temperature-dependent fatigue material data		•			
	Parameter databases		•			
	User defined analysis templates - define methods and parameters in one selection		•			
Fatigue methods and solver	High cycle fatigue – stress-life	•	•	•		
	Low cycle fatigue – strain-life	•	•	•		
	Infinite life – safety factor / margin of safety / degree of utilization	•	•	•		
	User defined fatigue methods		•	•		
	Structural stress seam weld analysis					•
	Notch stress seam weld analysis (incl notch severity)					•
	Stress based spot weld analysis					•
	Force based spot weld analysis					•
	User defined weld methods					•
	Multiple mean stress influence methods		•	•	•	•
	Multiaxial fatigue		•	•	•	•
	Notch/size effects – stress gradient correction		•	•	•	•
	Localized parameters (material/parameter map)		•	•		
	Fatigue below surface method		•	•		
	Use material data for user defined probability of survival		•	•		•
Multiple damage accumulation rules (linear)		•	•	•		
Short-fiber reinforced composites (reference SN-curve approach)				•		

General capabilities	Specific capabilities	Simcenter 3D Durability Wizard	Simcenter 3D Specialist Durability Modeling	Simcenter 3D Specialist Durability solver	Simcenter 3D Specialist Durability Composite Fatigue	Simcenter 3D Specialist Durability for Connections
Fatigue methods and solver <i>(continued)</i>	Intra-ply fatigue of endless-fiber composites (unidirectional/woven. etc)				•	
	Inter-ply fatigue of endless-fiber composites (unidirectional/woven. etc)				•	
	Automatic iteration of FE runs to account for global stiffness changes				•	
	Arbitrary damage accumulation				•	
	User defined damage rules for composites				•	
	Parallel processing (local and on external machines)		•	•	•	•
	Different methods (e.g. stress-life and weld) on different locations(groups) in one analysis		•	•	•	•
	Different methods (e.g.different parameters) on one group in one analysis		•	•	•	•
Postprocessing	Damage/lifetime	•	•	•	•	•
	Detailed analysis of stress and strain (max/min/max amplitude, mean)		•	•	•	•
	Mileage/Real lifetime		•	•	•	•
	Remaining usable lifetime		•	•	•	•
	Design life factors		•	•	•	•
	Safety factors / Degree of utilization	•	•	•	•	•
	Temperature overview (min/max), Modeller and solver		•	•	•	•
	Individual for groups		•			
	Individual for events of duty cycles		•			
	For intermediate time steps		•		•	
	Hot spot detection		•			
	Detailed function analysis on strain gauge and individual nodes/elements		•			
	Function analysis on all critical planes		•			
	Biaxiality plots		•			
	Hysteresis plots		•			
	Parametric plots of stress/strain/temperatures (peanut plots)		•			
	Damage accumulation time histories		•			
Load contribution analysis		•				
Event contribution analysis		•				

Legend:

• = included in module

Note: Simcenter 3D Engineering Desktop is a minimum prerequisite for all Simcenter 3D products. Other dependency or prerequisites may apply for individual products.

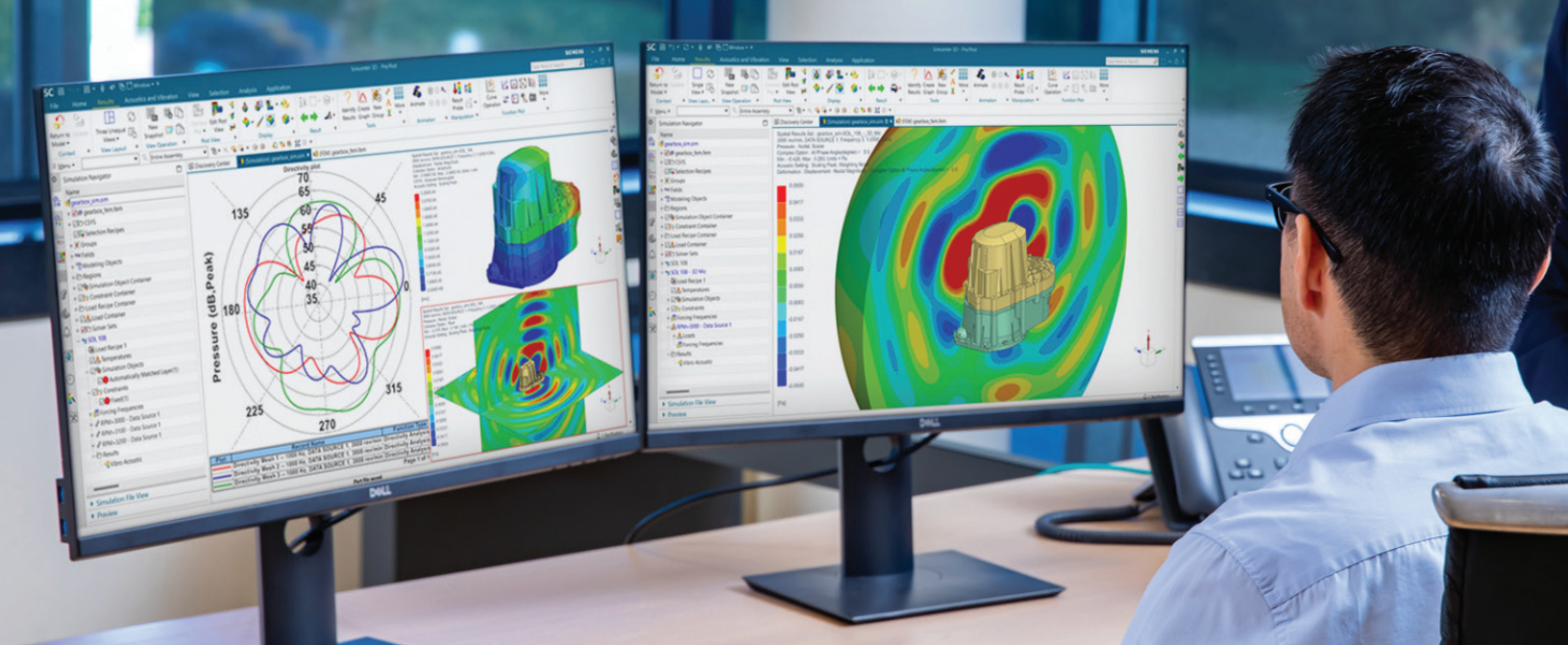

DIGITAL INDUSTRIES SOFTWARE

Simcenter 3D for acoustics simulation

Optimizing the sound quality of products

Solution benefits

Accelerate creating acoustic simulation models from complex geometries based on CAD, a previous mesh or from scratch

Solve acoustics, vibro-acoustics and aero-acoustics efficiently from a single interface using powerful FEM/ BEM and ray acoustics solvers

Covers interior, exterior, mixed problems and support for all typical sources, boundary conditions and materials to realistically capture source generation and wave propagation

Supports multiple RPM problems for rotating machinery (e-drives, engines, gearboxes and rotating components) provided for preprocessing (synthesis of waterfall and order cut loads), solver and postprocessing (campbell, order cursors, etc.)

Interpret results easily using auralization in addition to visual plots and animations

Simcenter™ 3D software offers a comprehensive solution to minimize noise and optimize the sound quality of products. Dedicated acoustic modeling capabilities, efficient solvers and easy-to-interpret visualization and auralization tools allow you to quickly gain insight into a design's acoustic performance for uncoupled acoustics, coupled vibro-acoustics and aero-acoustic applications. Simcenter is part of the Siemens Xcelerator business platform of software, hardware and services.

Accelerate acoustic meshing and modeling

Advanced features, such as surface wrapping, convex meshing, mesh thickening and the ability to create hybrid (hexa-tetra) meshes, help you accelerate acoustic meshing processes more than traditional preprocessors. The availability

of various material models for both structures and fluids, plus the wide variety of structural and acoustic boundary conditions and loads allow you to efficiently set up your analysis.

Deliver high-fidelity vibro-acoustic simulations in the most efficient way

Simcenter 3D increases the realism in your simulations by providing support for loads or source creation from test data and predecessor multibody or computational fluid dynamics (CFD) simulations.



Acoustics

SIEMENS

[siemens.com/simcenter3d](https://www.siemens.com/simcenter3d)

Simcenter 3D for acoustics simulation

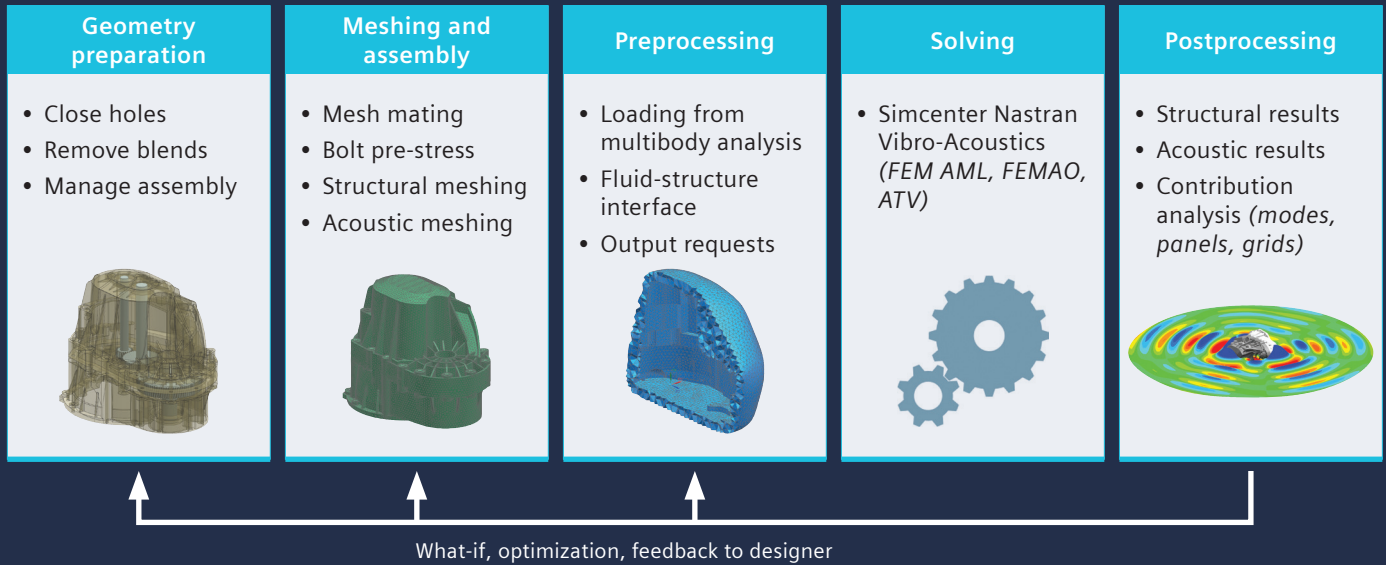

Simcenter Nastran software is used to rapidly solve complex interior and exterior acoustics problems thanks to key features like automatically matched layer (AML) and finite element adaptive order (FEMA0) technology, which allow you to use small fluid meshes with an optimal number of degrees-of-freedom (DOF) per frequency.

Faster design-analysis iterations with CAD-CAE-test associativity

Simcenter 3D seamlessly links to computer-aided design (CAD), computer-aided engineering (CAE) and even test data. Any design modification can be easily introduced to the structural and/or acoustic model, eliminating multiple conversions between [file formats](#) and recreating models.

Gain instantaneous insight with acoustic-specific post-processing

Simcenter 3D provides easy-to-interpret and intuitive postprocessing tools to investigate noise as a sound pressure level (SPL), acoustic power or directivity. Path, modal and panel contribution analysis helps to rapidly identify the important noise sources and their propagation.

In addition to visual postprocessing capabilities, Simcenter 3D offers auralization capabilities that let you actually listen to acoustic simulation results to evaluate noise contributions and sound quality for different versions of your product design.

Providing a platform for multidiscipline simulation

The Simcenter 3D acoustics solution is part of a larger, integrated multidiscipline simulation environment with the Simcenter 3D Engineering Desktop at the core for centralized pre- and postprocessing for all Simcenter 3D solutions. This integrated environment helps you to achieve faster CAE processes and streamline multidiscipline simulations that integrate acoustics and other disciplines, like e-drive noise predictions based on electromagnetic (stator) and structural (gearbox bearing) loads computed in Simcenter 3D Electromagnetics and Motion.

Industry applications

Since noise can impact health, and a quiet product is often perceived as higher in quality, companies are adopting efficient processes and tools to optimize the noise performance of their products.

Aerospace and defense

With Simcenter 3D, aviation engineers can predict cabin noise generated by turbulent boundary layers (TBL) on the fuselage or by aero-acoustic noise coming from the environmental control system (ECS). Exterior noise can be tackled using the high-end boundary element method (BEM), finite element method (FEM) and ray acoustics solvers. To assess the environmental noise footprint of drones and other urban air mobility craft, engineers can predict **propeller noise** on both a component level (aero-acoustic solutions based on CFD input) and at the level of far propagation, such as in a city scape (ray acoustics solution). Spacecraft engineers can reduce the risk of their acoustic verification tests by evaluating them virtually in Simcenter 3D.

Automotive and transportation

During vehicle development and improvement programs, the capabilities of Simcenter 3D can deliver noise, vibration and harshness (NVH) engineers with valuable insight into acoustic, vibro-acoustics and aero-acoustic noise contributions in the vehicle cabin and exterior environment for pass-by noise predictions or to design acoustic vehicle alerting systems (AVAS).

Consumer goods

Building powerful, high-quality speakers, silent vacuum cleaners and washing machines and other noise-free consumer goods requires advanced noise engineering and sound characterization features provided by Simcenter 3D.

Industrial machinery

Simcenter 3D acoustic modules provide the necessary features to evaluate machine-radiated noise, including capturing the effect of encapsulations with sound treatments.

Marine

Acoustic features of Simcenter 3D can be used to study complex underwater radiation from ship hulls, propellers and submarine hull reflections of sonar waves.

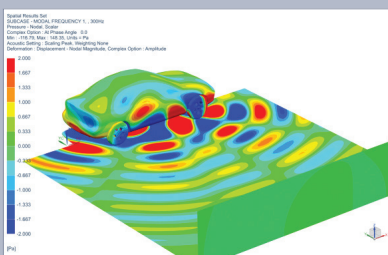
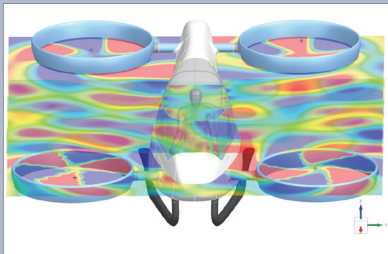
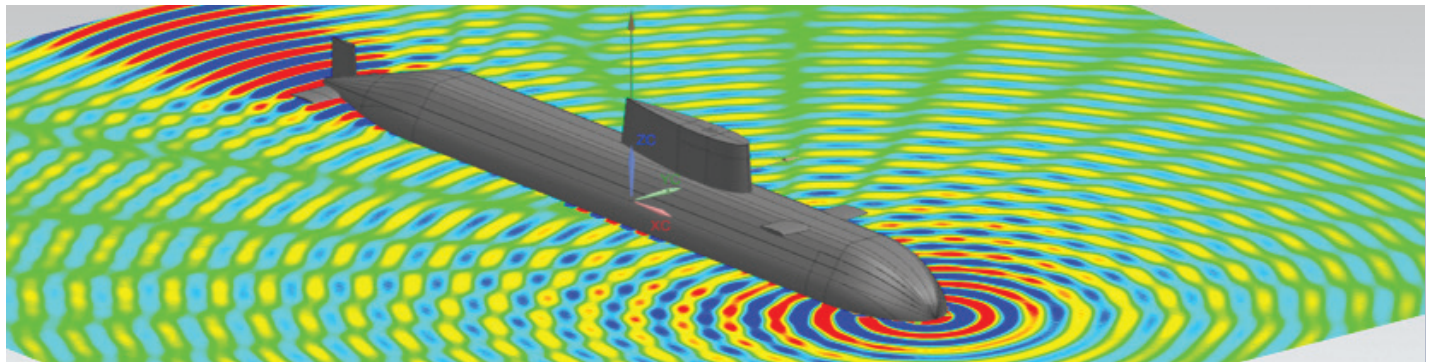

- Structural acoustics
- Aero-vibro-acoustics
- Component noise radiation
- Full vehicle scattering
- Cabin vibro-acoustics
- Transmission loss
- Room acoustics
- FEM/BEM/Ray acoustics

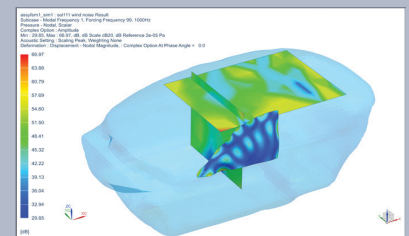
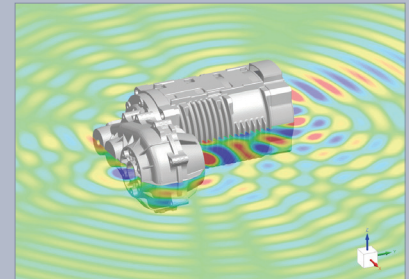

Simcenter 3D

Meshing for Acoustics

Using Simcenter 3D Meshing for Acoustics software helps you create meshes for FEM and BEM acoustic analysis. The module provides user-friendly, leading-edge functionalities to create an acoustic fluid mesh, both for interior as well as exterior acoustic applications, starting from an existing structural mesh or CAD geometry.

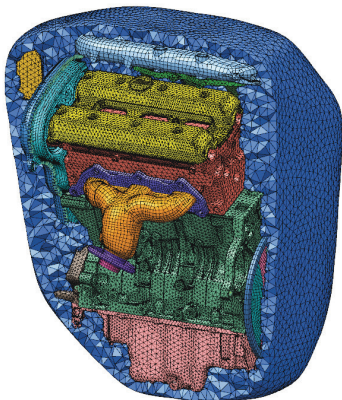
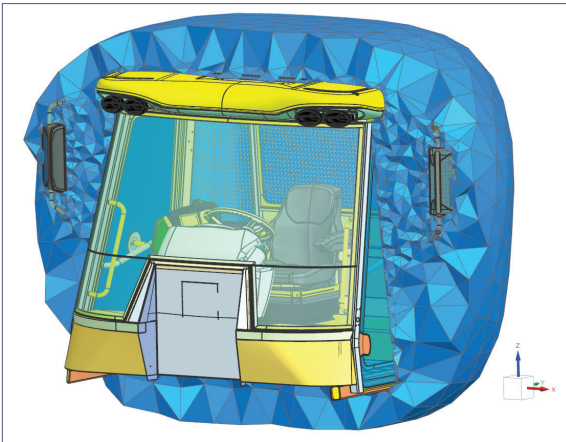

Module benefits

- Start from a structural FEM model or CAD geometry
- Accelerate the acoustic meshing process for complex geometries

Key features

- Hybrid mesh and polygon-based coarsening, hole-filling and rib-removal tools
- Interior and exterior surface-wrapping technology based on input of CAD or CAE model
- Easy creation of convex outer boundary surface to construct FEM meshes for exterior acoustics
- Hybrid hexa-dominant hexa and tetra mesher for fluid volumes facilitating efficient solving
- Structural shell mesh thickening (reverse of mid-surfacing) to derive boundary surfaces of FEM fluid cavities
- Automatic single step meshing for acoustic applications: component exterior noise radiation and panel transmission loss

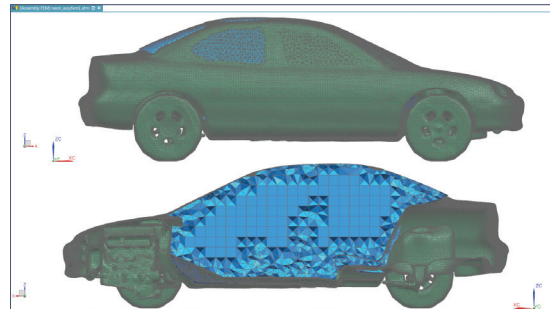

Simcenter Nastran Advanced Acoustics

Simcenter Nastran Advanced Acoustics software provides support for standard loads and boundary conditions, and key technologies like AML and FEMAO, to rapidly resolve acoustic simulations. It is well suited to study the acoustic radiation of components and pass-by noise of full vehicles, transmission loss of duct systems like intakes and exhausts or mufflers and transmission loss of panels.

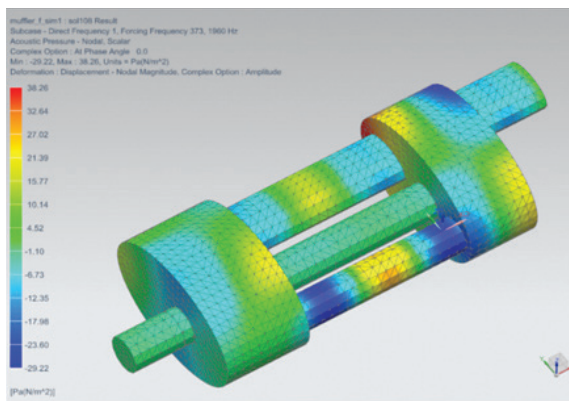

Module benefits

- Performs vibro-acoustic (SOL108/SOL111) simulations for interior or exterior noise
- Study exterior acoustics with lean FEM models thanks to embedded AML technology
- Efficiently simulate broadband acoustic problems using the adaptive FEMAO solver

Key features

- Support standard loads and boundary conditions, as well as specific acoustic boundary conditions like duct modes and acoustic diffuse field (random) loads
- Pressure loads on structural surfaces from other acoustic or CFD analysis
- Porous and temperature-dependent fluid materials, mean convective flow effects, frequency-dependent surface impedance and transfer admittance between pairs of surfaces
- Compute sound pressure, intensity and power for virtual microphones located inside or outside the meshed fluid volume

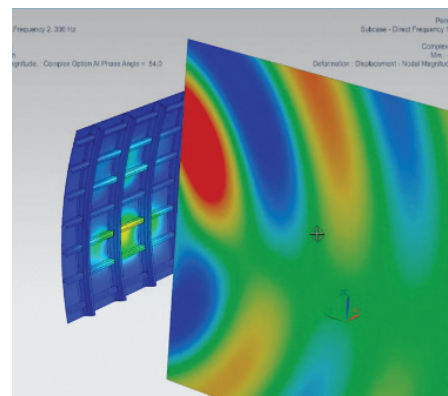
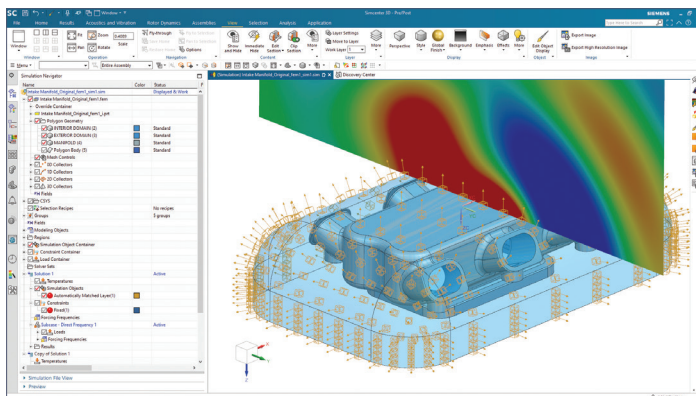

Simcenter Nastran Acoustics Trim

With the ongoing trend of electrification and light-weighting in the transportation industry, trim materials with sound absorbing capabilities are becoming more important. This means the need to simulate trim materials for acoustic performance is also increasingly important to ensure the trim can efficiently tackle noise problems at the higher frequencies that electric drives typically impose. Trim materials (visco-elastic and poro-elastic materials) are also found in other industries, like electronics. Using Simcenter Nastran Acoustics Trim helps you model acoustic trim treatments used to passively dampen sound using key technologies for accurate and efficient solving. Simcenter Nastran Acoustics Trim is well suited to study acoustic treatments of car panels (floor, door, dash), thermo-acoustic shields that are placed on top of powertrain components or even to assess the acoustic effects of foam filling in your over-ear headphones.

Module benefits

- Quickly analyze the impact of flat trim layers
- Reduce the computational costs for accurate solving with poro-elastic materials by benefiting from the fast and efficient FEMAO

Key features

- Equivalent transfer matrix calculation with vibro-acoustic transfer admittance and postprocessing of the alpha coefficients
- Full Biot formulation for accurate simulation of poro-elastic materials
- Adaptive order (AO) technology applied to poro-elastic materials
- Embedded vibro-acoustic coupling with poro-elastic meshes for both conformal and non-conformal meshes
- Computation of the dissipated powers through poro-elastic materials (structural, viscous, thermal losses)

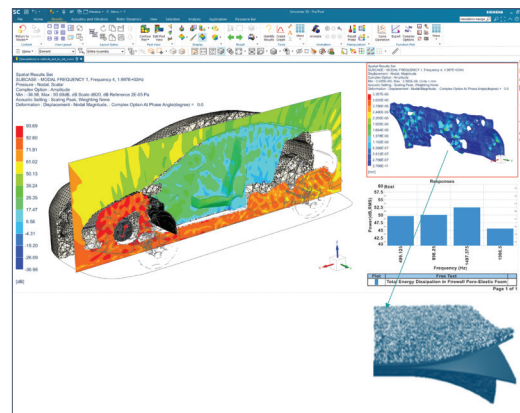
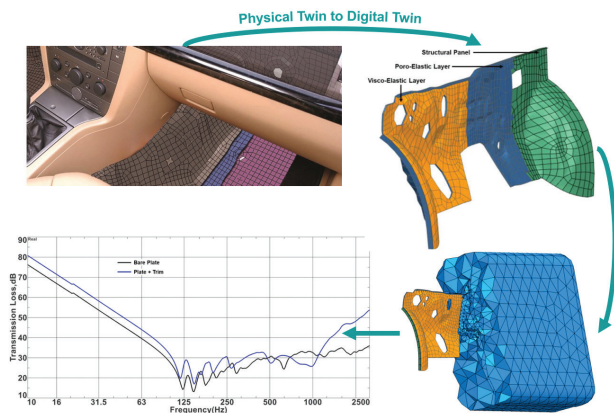

Simcenter 3D

Acoustic Transfer Vector

Simcenter 3D Acoustic Transfer Vector software supports computing the acoustic transfer vector (ATV), expressing the sensitivity of the pressure response at a virtual microphone per unit normal velocity at field points on a radiating surface. It can be re-used to quickly predict the acoustic response for any surface vibrations. Similarly, vibro-acoustic transfer vectors (VATV) express the sensitivity of microphone pressures for unit force applied at points on a structure. Also, VATV can be quickly reused for predicting the acoustic response to any force loading. Modal participation factors (MPFs) can also be used with ATVs in a modal acoustic transfer vector (MATV) context.

Module benefits

- Use ATV to compute noise from rotating machines with multiple revolutions per minute (RPM) loads up to 100 times faster
- Use VATV to quickly evaluate cabin noise due to multiple load cases of flow-induced pressure loads, like wind loads and turbulent boundary layers

Key features

- ATV results can be obtained from Simcenter Nastran, BEM and Ray Acoustic solutions
- ATV can be interpolated when used in a forced response context
- Evaluate acoustic pressure, power, panel, grid and modal contributions for ATV response

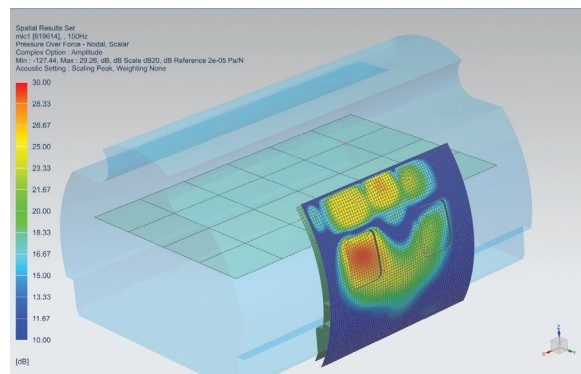
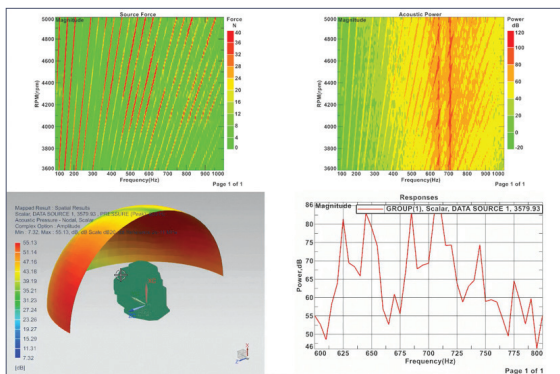

Simcenter 3D

Aero-Vibro-Acoustics

Simcenter 3D Aero-Vibro-Acoustics software supports creating aero-acoustic sources close to noise-emitting turbulent flows and allows you to compute their acoustic response in the exterior or interior environment; for example, for noise coming from heating, ventilation and air-conditioning (HVAC) units, environmental control system (ECS) ducts, train bogies and pantographs, cooling fans, ship and aircraft propellers and more. The product also allows you to define wind loads acting on structural panels, leading to a vibro-acoustic response; for instance, in a car or aircraft cabin.

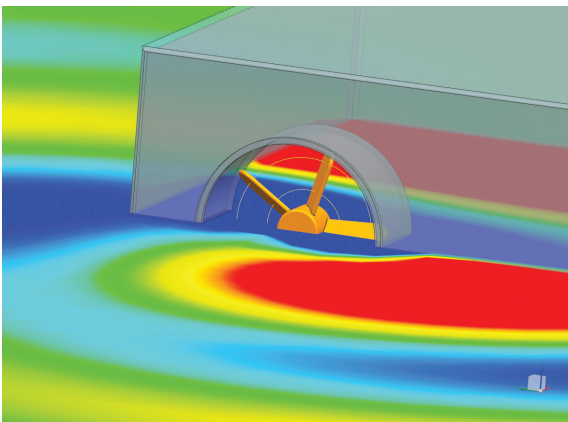
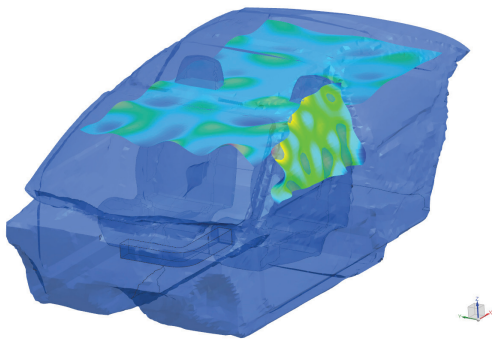

Module benefits

- Derive lean, surface pressure-based aero-acoustic sources for stationary and rotating surfaces
- Provide scalable and user-friendly load preparation for aero-vibro-acoustic wind noise simulations
- Import binary files with load data directly in Simcenter Nastran for response computation

Key features

- Conservative mapping of pressure results from CFD to the acoustic or structural mesh
- Equivalent aero-acoustic surface dipole and volume quadrupole sources
- Equivalent aero-acoustic fan sources for both tonal and broadband noise
- Wind loads, using either semi-empirical turbulent boundary layer models or mapped pressure loads from CFD results
- Aero-acoustics radiating sources on permeable surfaces

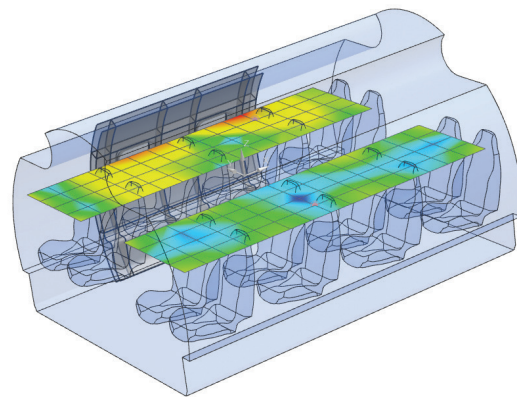

Simcenter 3D Load Identification

Leveraging Simcenter 3D Load Identification enables you to get accurate dynamics loadings of a structure. Operational loads are very important for accurate response prediction but are often impossible or difficult to measure directly.

This product offers several ways of identifying the operational forces from measured data, either by the mount stiffness method or an inverse matrix method. For instance, in an inverse matrix method, the operational vibration data can be measured in operational conditions and the transfer functions (FRFs) can be measured in controlled lab conditions or obtained from simulations. These data are then combined in an inverse load identification case.

In addition, Simcenter 3D Load Identification supports a modal expansion solution to create enriched vibration results on a full FE model based on measured vibrations at just a few locations.

Finally, a second method to derive structural surface vibrations is provided through inverse numerical acoustics, in which measured pressure responses at only a few points near the structure are used together with acoustic transfer vectors to identify the full surface vibrations. The obtained vibration field can then be used further for acoustic radiation analysis.

Module benefits

- Determine operational forces or vibrations that are difficult or impossible to measure directly
- Get a more realistic simulation by applying more accurate loading
- Combine measured loading data with FE simulations

Key features

- Mount method to estimate mount forces by combining operational vibration data at each side of the mount and mount stiffness data
- Inverse matrix method by a combination of operational measurements and transfer functions, based on all measured data or a combination of operation measurements and simulation data
- Straightforward application and reuse of the identified forces or vibrations to the simulation model

Test



Mount stiffness method

- Operational vibrations on both ends of the mounts are measured
- Mount stiffness FRFs measured in lab



$$F(\omega) = K(\omega)[X_s(\omega) - X_t(\omega)]$$

Inverse matrix method

- Operational vibrations are measured
- FRFs measured in lab

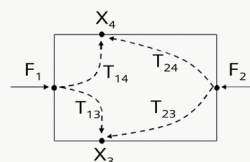

$$\begin{bmatrix} F_1 \\ F_2 \end{bmatrix} = \begin{bmatrix} T_{13} & T_{23} \\ T_{14} & T_{24} \end{bmatrix}^{-1} \begin{bmatrix} X_3 \\ X_4 \end{bmatrix}$$

Simcenter 3D Environment for BEM Acoustics

Simcenter 3D Environment for BEM Acoustics software supports generating a ready-to-run acoustic or vibro-acoustic simulation model for direct BEM and indirect BEM solvers, and provides comprehensive postprocessing tools to analyze the acoustic or vibro-acoustic results.

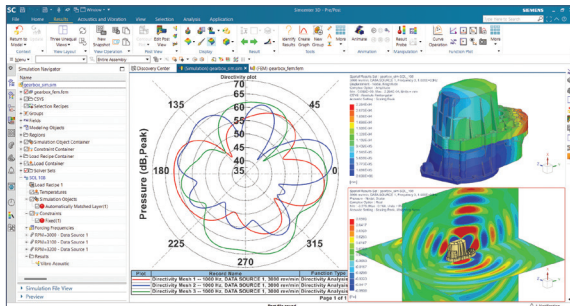
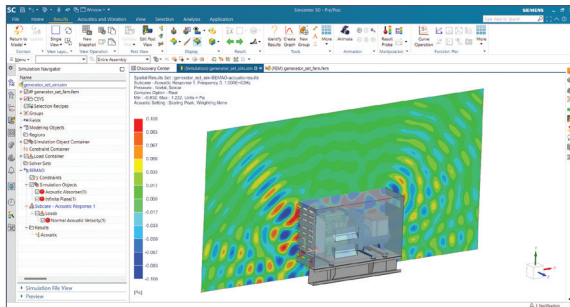

Module benefits

- Streamline acoustic BEM model creation for both standard and BEMAO solvers in a user-friendly interface
- Support pure acoustic problems as well as weakly or fully coupled vibro-acoustics response via modal-based definition of the structure
- Leverage dedicated postprocessing capabilities to improve users' engineering insight and productivity

Key features

- Provide all standard structural and acoustic loads and boundary conditions to describe your vibro-acoustic problems accurately
- Prepare deterministic as well as random acoustics and vibro-acoustics analysis
- Standard postprocessing of acoustic results like pressure and acoustic power and structural vibrations
- Dedicated diagnostic plots showing panel contributions and structural modal contributions to the acoustic pressure or power

Simcenter 3D

Acoustics BEM solver

The Simcenter 3D Acoustics BEM solver is used to predict the acoustic response in both enclosed and unbounded domains using a mesh for only the boundary of the fluid domain. Vibro-acoustic analysis is supported by coupling the acoustic fluid with a structural modal model. Structural vibrations can also be imposed on the BEM fluid using weak vibro-acoustic coupling.

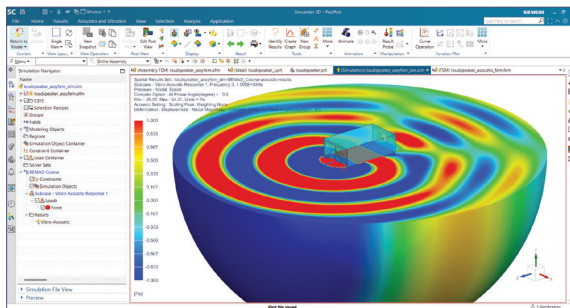
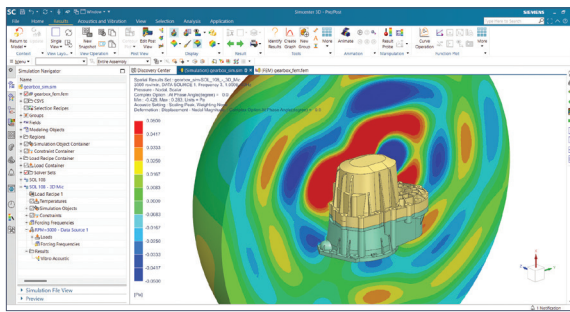

Module benefits

- Fast and efficient BEM solvers for solving both purely acoustic as well as vibro-acoustic problems
- A multitude of acoustic and structural loads and boundary conditions are supported for an accurate description of your vibro-acoustic simulation model
- Automatic BEM model corrections for free and junction edges

Key features

- Direct and indirect acoustic uncoupled solutions
- Indirect vibro-acoustic, weakly coupled and strongly coupled solutions
- Deterministic as well as random acoustics and vibroacoustics analysis
- Returns standard acoustic and structural response results
- Provides structural panel contributions and modal contributions to the acoustic pressure or power
- Direct and iterative solving

Simcenter 3D

Acoustics BEMAO solver

The Simcenter 3D Acoustics BEMAO Solver is used to predict the acoustic response in both enclosed and unbounded domains using a mesh for only the boundary of the fluid domain, but with a significant solution speed-up when compared to the Simcenter 3D Acoustics BEM Solver. The faster solution time comes from the AO technology in the BEMAO solver that relies on high-order shape functions and an a-priori error estimator to efficiently reduce the number of degrees-of-freedom. Vibro-acoustic analysis is supported by coupling the acoustic fluid with a structural modal model. Structural vibrations can also be imposed on the BEM fluid using weak vibro-acoustic coupling.

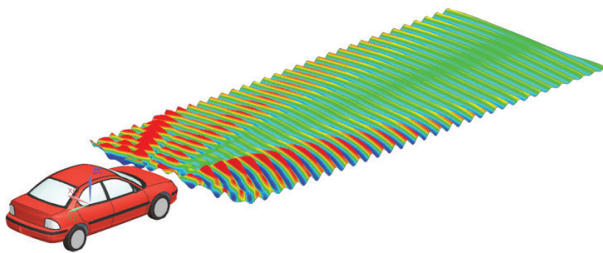

Module benefits

- Quickly and efficiently simulate broadband acoustic and vibro-acoustic problems without having to use a very fine mesh
- Accurately represent vibro-acoustics models using a multitude of acoustic and structural loads and boundary conditions
- Accurately account for BEM-specific model hurdles (for example, free/junction edges, quadrature rules, near-field singularities)

Key features

- Automatic BEMAO model corrections for free and junction edges; improved automatic quadrature rules; better handling of near-field singularities; accelerated fast-multipole matrix assembly
- Indirect acoustic uncoupled solutions
- Indirect vibro-acoustic, weakly coupled and strongly coupled solutions
- Deterministic as well as random acoustics and vibro-acoustics analysis
- Provides structural panel contributions and modal contributions to the acoustic pressure or power

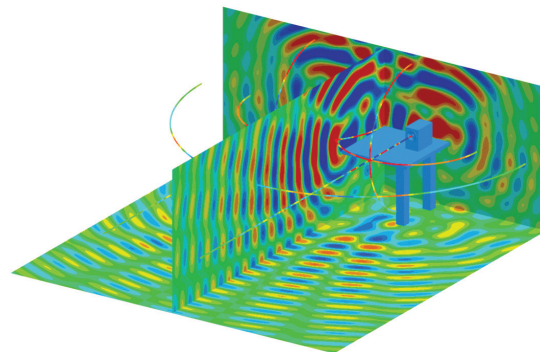

Simcenter 3D

Acoustics Time Domain BEM solver

Using Simcenter 3D Acoustics Time Domain BEM software enables BEM solutions to solve transient acoustic and vibro-acoustic phenomena. As opposed to the frequency-domain based BEM solvers, leveraging Simcenter 3D Acoustics Time Domain BEM Solver gives the possibility to solve problems involving impulsive short time excitation signals in the time domain. This BEM solver is well suited for applications such as parking sensor design and door slam analysis.

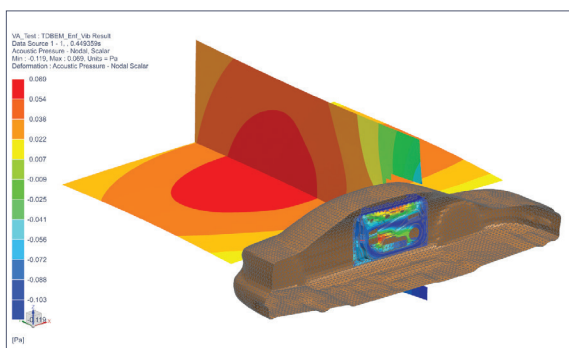
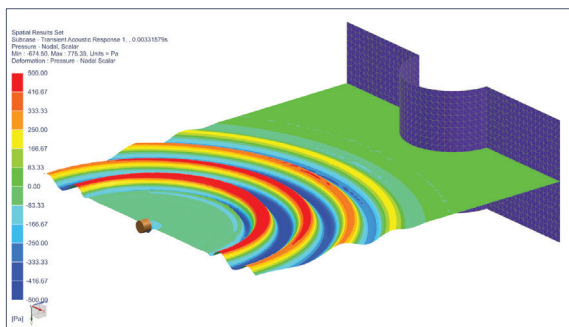

Module benefits

- Allows for accurate modeling of transient infinite domain problems
- Provides solutions for purely acoustics and vibro-acoustic problems
- Provides a fast and efficient solver in the time domain, even when using large models

Key features

- Dedicated solver environment Simcenter 3D Acoustics Transient BEM for time domain BEM computations, including two analysis types: transient acoustic and transient vibro-acoustic
- Supports multiple loads and boundary conditions
 - Transient acoustic: acoustic monopole, plane wave, infinite plane, acoustic absorber, transfer admittance
 - Transient vibro-acoustic: force applied on structure (with mode set representation), pre-computed vibrations, infinite plane, acoustic absorber, transfer admittance, panel

Simcenter 3D Acoustics HPC

A high-performance computing (HPC) package is available. Using Simcenter 3D Acoustics HPC software enables you to execute acoustic FEM or BEM computations in multiprocessing mode on the parallel hardware of your choice. Parallel calculation sequences are implemented using the message passing interface (MPI) communication standard. In the case of FEM vibro-acoustics, this product embeds the distributed memory parallelization (DMP) capability of Simcenter Nastran.

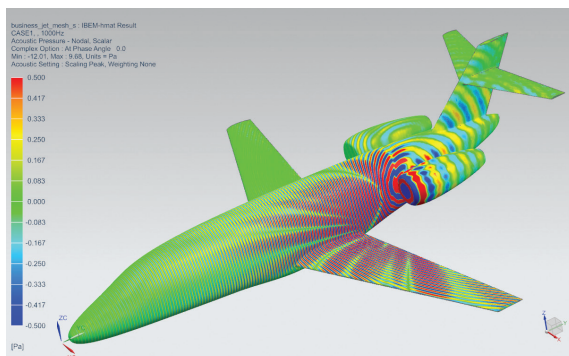
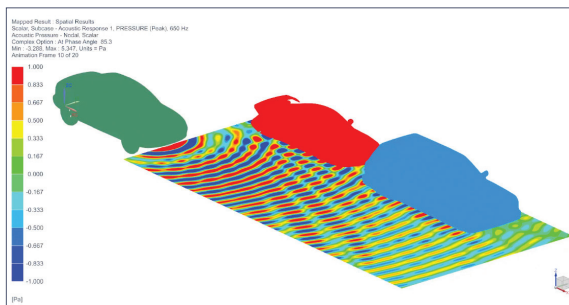

Module benefits

- Accelerates acoustic computations using multithreading, shared memory parallelization (SMP), multiprocessing and DMP
- This product supports high-performance computing for Simcenter 3D Acoustics FEM and BEM solvers

Key features

- Solvers can run in high-performance computing mode on multi-node clusters as well as on multi-core workstations
- Allows you to tackle problems with many frequencies with DMP for which a near-linear parallel speed up can be expected

Simcenter 3D

Ray Acoustics

Simcenter 3D Ray Acoustics is used to predict acoustic responses with very high frequencies and for very large geometries, in both enclosed and unbounded domains. Unlike FEM or BEM acoustic solvers, ray acoustics solutions are not based on a fine discretization of the domain. Therefore, the solution is not bounded by an upper frequency limit or the model size and solving is done orders of magnitude faster than FEM or BEM.

Simcenter 3D Ray Acoustics integrates an engineering environment in Simcenter 3D to generate and postprocess a ray acoustic model, as well as a ray acoustic solver, which is the ICARE solver from the Scientific and Technical Center for Building (CSTB).

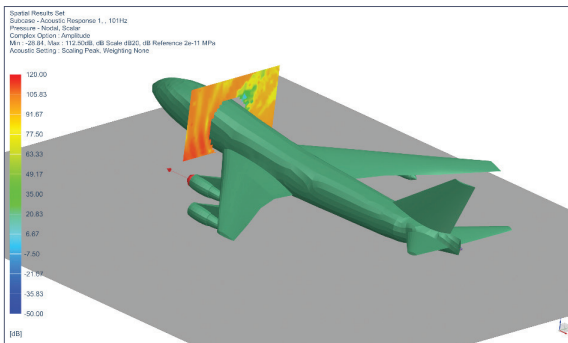
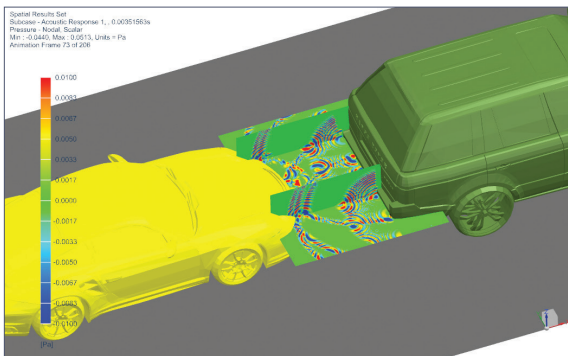

Module benefits

- Solve high-frequency acoustic simulations for large models in a fraction of the time required with FEM or BEM solvers
- A coarse mesh can be used provided it captures the model's geometry, simplifying model creation
- Standard acoustic loads and boundary conditions are supported for an accurate description of the simulation model
- Advanced results and postprocessing to explore ray path arrivals, source contributions, binaural acoustic responses or sound quality criteria

Key features

- Returns acoustics results in both the frequency and time domain
- Simulates the propagation of acoustic energy with adaptive beam tracing technology
- Accurately simulates reflections on curved surfaces despite the coarse mesh discretization
- Captures multi-order diffraction effects and creeping waves
- Captures late reflections and diffusion effects with particle tracing technology
- Supports standard acoustic loads including point source directionality
- Dedicated solution types to calculate acoustic FRFs and ATVs to support advanced NVH workflows (see Simcenter 3D Acoustic Transfer Vector page)

Simcenter 3D Acoustics Auralization

Leveraging Simcenter 3D Acoustics Auralization immerses you into a virtual acoustic environment where you can evaluate the acoustic performance of your designs by listening to simulation results rather than only looking at plots and curves. This tool creates listening scenarios based on simulated or externally recorded sources and simulated transfer functions obtained from either the Simcenter 3D Ray Acoustics or Simcenter 3D Acoustics BEM or FEM solutions. With Simcenter 3D Acoustics Auralization, you can visualize the resulting time data, listen to the scenario and make changes to the individual tracks to improve the sound quality of your product. Moreover, using the embedded sound quality metrics tool, you can quantitatively evaluate the sound quality based on dedicated loudness and sharpness metrics.

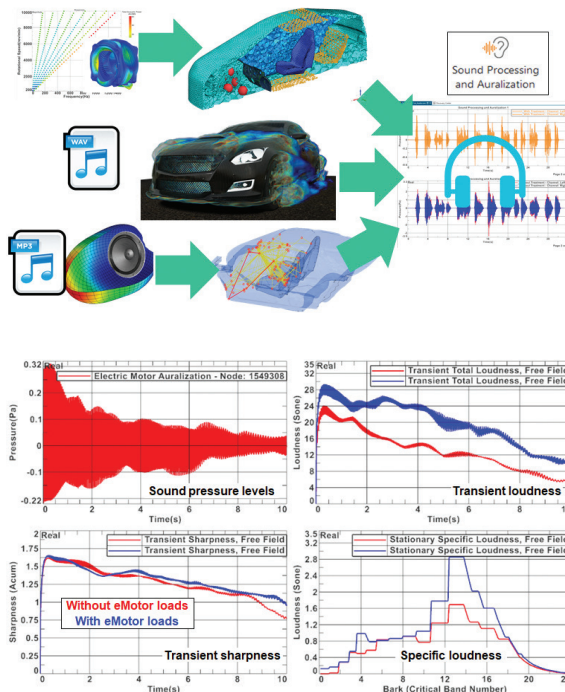

Module benefits

- Listen to your acoustic simulation models and experience the effect of design changes on the subjective perception of your product
- Assess your design in its intended user environment by creating complex listening scenarios
- Objectively evaluate acoustic performance with industry-standard sound quality metrics such as loudness and sharpness for sound quality evaluation

Key features

- Define acoustic sources based on
 - Time domain data (from wav/mp3 recordings or processed acoustic pressure simulation results)
 - Acoustic pressure order-cut simulation results and desired RPM profiles for rotating machinery
- Combine each source with the corresponding transfer function based on
 - Simulated ray acoustics impulse responses
 - Simulated transfer functions from Simcenter 3D Acoustics FEM or BEM models by processing the results inside Simcenter 3D
- Plot time data for complex scenarios and listen to the resulting soundscape
- Turn on/off or modify individual tracks to assess the impact on total sound perception
- Evaluate sound quality metrics (loudness and sharpness)

Capabilities chart

General capabilities	Specific capabilities	FEM acoustics										BEM acoustics				Simcenter 3D Ray Acoustics	Simcenter 3D Load Identification *	Simcenter 3D Acoustics Auralization	
		Simcenter 3D Meshing for Acoustics	Simcenter 3D Noise and Vibration Modeling *	Simcenter Nastran Basic **	Simcenter Nastran Dynamic Response *	Simcenter Nastran Advanced Dynamics bundle *	Simcenter Nastran Advanced Acoustics	Simcenter Nastran Acoustics Trim	Simcenter 3D Aero-Vibro-Acoustics	Simcenter 3D Environment for BEM Acoustics	Simcenter 3D Acoustics BEM solver	Simcenter 3D Acoustics BEMAO solver	Simcenter 3D Acoustics Time Domain BEM solver	Simcenter 3D ATV	Simcenter 3D Acoustics HPC				
Meshing	Surface wrapper mesh for FEM and BEM acoustics	•																	
	Convex surface mesher	•																	
	2D mesh with thickness (volumize)	•																	
	Hybrid meshing for acoustics (tetrahedron and hexahedron)	•																	
	Automatic open duct mesh creation	•																	
	Generate acoustic envelope from structural mesh	•																	
	Cavity meshing	•																	
	Coarsener/remesher	•																	
	Hole filling	•																	
	Rib removal	•																	
Boundary condition	Acoustics loads: monopoles								•										
	Acoustics loads: point source with directionality																	•	
	Acoustics loads: plane waves								•										
	Acoustics loads: panel normal velocity								•										
	Acoustics loads: panel source																	•	
	Acoustics loads: dipoles, distributed plane waves, enforced acoustic pressure, radiating sources								•										
	Acoustics loads: noise source																	•	
	Aero-acoustic loads: fan source, surface dipoles, quadrupoles										•								
	Turbulent boundary layer loads										•								
	Mapped force loads from flow induced loads		•								•								
	Duct modes								•										
	Transfer admittance to model perforated wall/sheet								•				•						
	Vibro-acoustic transfer admittance to model trim between structural plate and acoustic cavity									•									
	Acoustic absorber (impedance) boundary condition								•				•						•
	Acoustic continuity to connect different domains								•										
Acoustic absorption, diffusion and transmission coefficients																		•	

General capabilities	Specific capabilities	FEM acoustics													BEM acoustics				
		Simcenter 3D Meshing for Acoustics	Simcenter 3D Noise and Vibration Modeling *	Simcenter Nastran Basic **	Simcenter Nastran Dynamic Response *	Simcenter Nastran Advanced Dynamics bundle *	Simcenter Nastran Advanced Acoustics	Simcenter Nastran Acoustics Trim	Simcenter 3D Aero-Vibro-Acoustics	Simcenter 3D Environment for BEM Acoustics	Simcenter 3D Acoustics BEM solver	Simcenter 3D Acoustics BEMAO solver	Simcenter 3D Acoustics Time Domain BEM solver	Simcenter 3D ATV	Simcenter 3D Acoustics HPC	Simcenter 3D Ray Acoustics	Simcenter 3D Load Identification *	Simcenter 3D Acoustics Auralization	
Boundary condition (continued)	Infinite plane to represent reflective surfaces																		
	Anechoic nonreflective boundary (AML)																		
	Anechoic end duct																		
	Convective flow effects																		
Materials	Acoustic fluid																		
	Poro-elastic materials																		
	Porous materials - Craggs, Delany-Bazely-Miki and Jonhson-Champoux-Allard																		
	Temperature dependent fluid for modeling																		
	Temperature dependent fluid for solving																		
	Humidity dependent fluid																		
Representations	Mode set representation																		
	Mode set response																		
	FRF set representation																		
	FRF set response																		
	ATV set representation																		
	ATV set response in Simcenter Nastran																		
	VATV set representation																		
	VATV set response in Simcenter Nastran																		
Solution	ATV, VATV and MATV response in noise and vibration solver																		
	RDMODES (Recursive domain method for computing structural modes faster)																		
	Fully/weakly coupled vibro-acoustics with finite element																		
	Fully/weakly coupled vibro-acoustics with boundary element																		
	Finite element method acoustics (FEM Acoustics)																		
	Finite element method adaptive order acoustics (FEMAO Acoustics)																		
	Vibro-acoustic transfer admittance																		
	Boundary element method adaptive order acoustics (BEMAO Acoustics)																		
	Acoustics transfer vector analysis (FEM Acoustics, BEM Acoustics and Ray Acoustics)																		
	Vibro-acoustic transfer vector analysis (FEM Acoustics)																		
	Modal expansion																		
	Inverse numerical acoustics																		
	Indirect/direct boundary element method acoustics (BEM Acoustics)																		

General capabilities	Specific capabilities								FEM acoustics			BEM acoustics							
		Simcenter 3D Meshing for Acoustics	Simcenter 3D Noise and Vibration Modeling *	Simcenter Nastran Basic **	Simcenter Nastran Dynamic Response *	Simcenter Nastran Advanced Dynamics bundle *	Simcenter Nastran Advanced Acoustics	Simcenter Nastran Acoustics Trim	Simcenter 3D Aero-Vibro-Acoustics	Simcenter 3D Environment for BEM Acoustics	Simcenter 3D Acoustics BEM solver	Simcenter 3D Acoustics BEMAO solver	Simcenter 3D Acoustics Time Domain BEM solver	Simcenter 3D ATV	Simcenter 3D Acoustics HPC	Simcenter 3D Ray Acoustics	Simcenter 3D Load Identification *	Simcenter 3D Acoustics Auralization	
Solution (continued)	Transient boundary element method (Transient BEM) acoustics																		
	Solving up to four parallel processes								•										
	Solving with more than four parallel processes										•	•							
Postprocessing	Pressure, acoustic velocity and intensity at microphone location and acoustic power		•							•									
	Contributions of structural modes, panel and grids on the total acoustic response		•							•									
	Directivity plots		•							•							•		
	Ray path analysis																•		
	Sound quality criteria																•		
	Contributions of individual sources to the total acoustic response																•		
	Listen to the resulting soundscape for time data																	•	
	Sound quality metrics (loudness and sharpness)																	•	

Legend:

If several • are present in a single row, interpret as "OR"
 If several cells are merged with one •, interpret as "AND"
 * = refer Simcenter 3D for structural dynamics
 ** = refer Simcenter 3D for structures

Note: Simcenter 3D Engineering Desktop is a minimum prerequisite for all Simcenter 3D products.
 Other dependency or prerequisites may apply for individual products.



DIGITAL INDUSTRIES SOFTWARE

Simcenter 3D for motion simulation

Create, validate and share mechanism designs with a fully integrated platform

Solution benefits

Accurately predict complex mechanism behavior

Quickly build and maintain motion models using an integrated CAE environment

Integrate systems and controls to simulate mechatronic systems

Use add-on modules to simulate specific applications like tires or drivetrains

Seamlessly share and use motion simulation results across Simcenter 3D as input for other types of CAE applications

Simcenter™ 3D software offers modeling and simulation that helps engineers understand and predict the functional behavior of mechanisms. It delivers a complete and robust set of capabilities to support all aspects of advanced dynamic, static and kinematic motion simulation. The early use of motion simulation is key to evaluating mechanism performance to increase design confidence and reduce risks.

Providing a platform for multidiscipline simulation

The Simcenter 3D motion solution is part of a larger, integrated multidiscipline simulation environment with the Simcenter 3D Engineering Desktop at the core for centralized pre-/postprocessing

for all Simcenter 3D solutions. Simcenter is part of the Siemens Xcelerator business platform of software, hardware and services. This integrated environment helps you to achieve faster computer-aided engineering (CAE) processes and streamline multidisciplinary simulations. It integrates motion and other disciplines like finite element models for flexible body analysis as well as connections with acoustics for gear whine analysis.



Motion

SIEMENS

[siemens.com/simcenter3d](https://www.siemens.com/simcenter3d)

Simcenter 3D for motion simulation

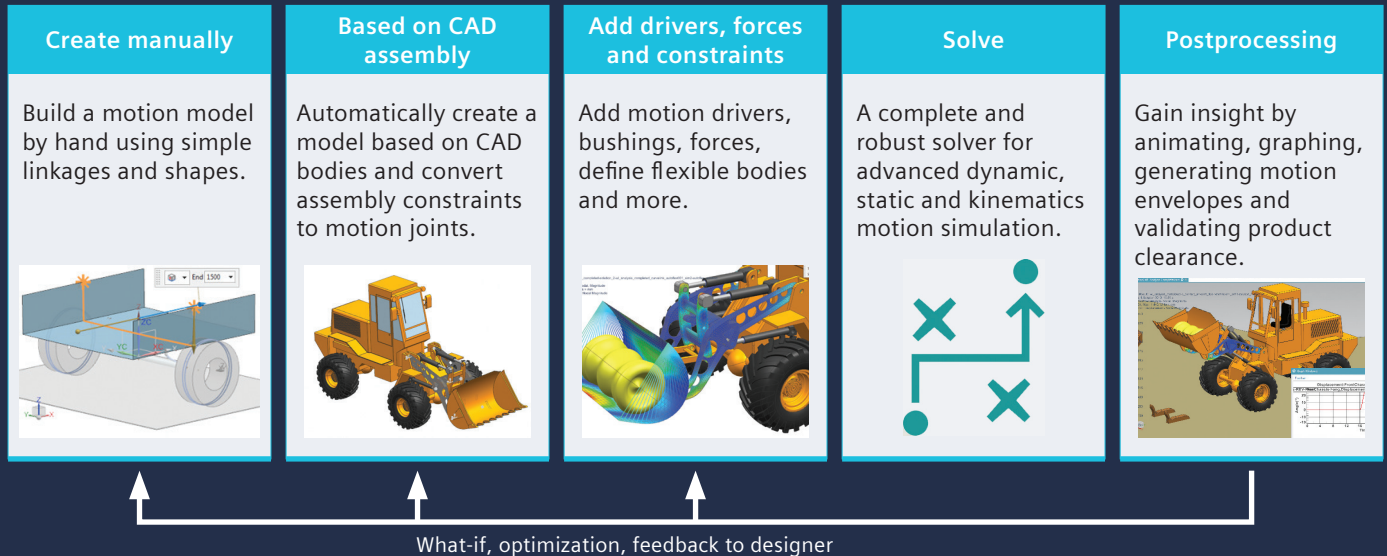

A motion simulation solution for both analysts and designers

Designers and analysts typically approach motion simulation from two different perspectives, where CAD designers start with CAD data, and analysts often start with only the engineering data. Simcenter 3D Motion solutions provide solutions that work for both designers and analysts. Analysts can use Simcenter 3D Motion to create new mechanism models by hand using simple primitive geometry for motion bodies. This helps you understand how a new assembly mechanism might work before applying any detailed geometry. Designers working with computer-aided design (CAD) assembly models during the detailed design stage can quickly convert these assemblies into a working motion model in seconds by converting the geometry bodies into mechanism motion bodies and assembly constraints into corresponding motion joints. This can save designers critical modeling time, so they can begin realizing how geometry will impact the performance of their mechanism.

Accurately predict complex mechanism behavior

The Simcenter 3D Motion solver is built on more than 30 years of proven technology and uses the most advanced numerical multibody solving techniques to deliver fast, stable and robust

simulation. Additionally, it provides accurate results for reaction forces, displacement, velocities and accelerations for rigid and flexible bodies. The loads obtained from the simulation can also be applied to structural analysis and durability, noise and vibration studies.

Integrate systems and controls to simulate mechatronic systems

Simcenter 3D can be integrated with leading control design tools and supports both model exchange and co-simulation methods to solve the mechanical system equations simultaneously with the controller or actuator system equations. This helps you understand how controls will impact the overall mechanism performance.

Seamlessly share results across Simcenter 3D

For certain types of structural, acoustics, vibration and durability analysis, it is critical to understand the loading conditions for the part or assembly being analyzed. You can seamlessly transfer loading conditions calculated with Simcenter 3D Motion solutions to the Simcenter 3D Engineering Desktop for use in other simulation applications. This will greatly improve productivity for you or your extended simulation team.

Industry applications

Understanding the operating environments for intricate mechanical systems – such as photocopiers, sliding sunroofs and wing flaps – can be challenging. Motion simulation calculates the reaction force, torque, velocity, acceleration and more for mechanical systems to allow you to study a broad range of product behaviors.

Automotive and transportation

Cars include a wide variety of mechanisms that impact vehicle performance and driver comfort. You can use Simcenter 3D to evaluate transmission, suspension and tire performance as well as mechanisms such as closures (sunroof), seats and doors.

Aerospace and defense

Aerospace customers use Simcenter 3D Motion to evaluate landing-gear performance as well as wing-flap mechanisms.

Marine

Using Simcenter 3D can help engineers simulate how rudder systems perform in addition to other on-board mechanisms, like cranes on a cargo ship.

Industrial machinery

Industrial machines move constantly, from complex production machines to robots and conveyors. Machine developers can use Simcenter 3D to enable their machines perform as expected.

Electronics

Electronics often have complex, well controlled moving mechanisms. Simcenter 3D can help you simulate the motion of photocopiers, scanners, disk drives and more.

Consumer products

Washing machines, dishwashers and toys all have mechanisms that end users rely on to meet their needs. Simcenter 3D can help you efficiently engineer these mechanisms.

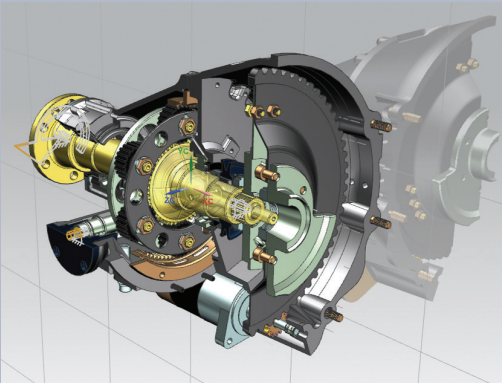
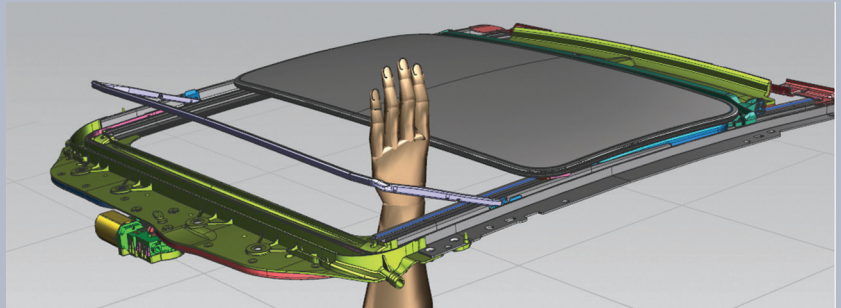
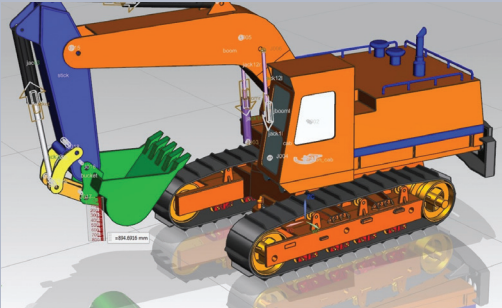

Rigid body
Flexible body
Co-simulation with controls
Interference checking
Drivetrain

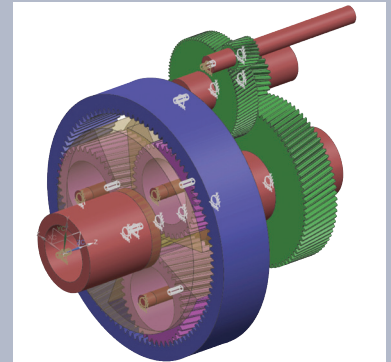

Simcenter 3D

Motion Modeling

Simcenter 3D Motion Modeling software provides multibody pre- and postprocessing capabilities to model, evaluate and optimize mechanisms. The module delivers a complete, yet simple-to-use set of capabilities to study the complex aspects of kinematics and dynamics during product development in industries such as aerospace, automotive, industrial machinery and electronics.

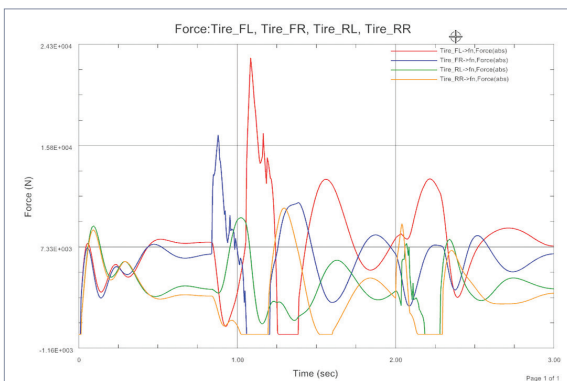
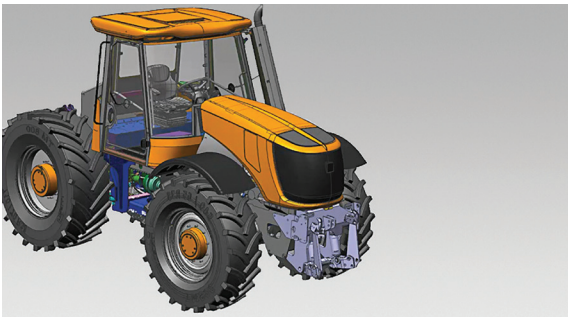

Module benefits

- Reduce expensive physical prototypes by using motion simulation to understand mechanism performance
- Gain insight into the kinematic and dynamic performance of a mechanism by animating, graphing and generating motion envelopes and validating product clearance

Key features

- Quickly convert CAD geometry and assemblies into fully functional motion models
- Seamlessly transfer motion results to other Simcenter 3D applications for structural analysis, durability, acoustics and more
- Includes a natural and direct interface to Simcenter Amesim™ software for accurate behavior of electronics, hydraulics and control components throughout the system

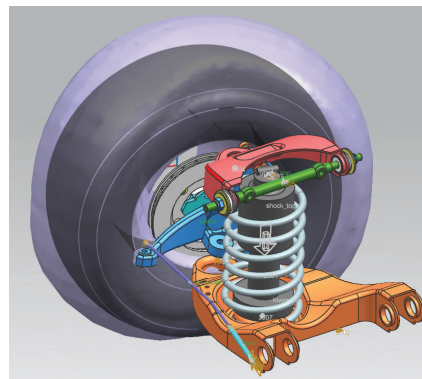

Simcenter 3D

Motion solver

Simcenter 3D Motion solver helps engineers predict and understand the functional behavior of parts and assemblies. This multibody dynamic solver delivers a complete and robust set of capabilities to solve all aspects of advanced dynamic, static and kinematic motion simulation.

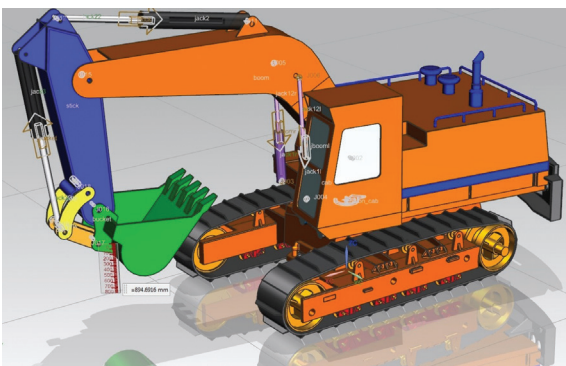
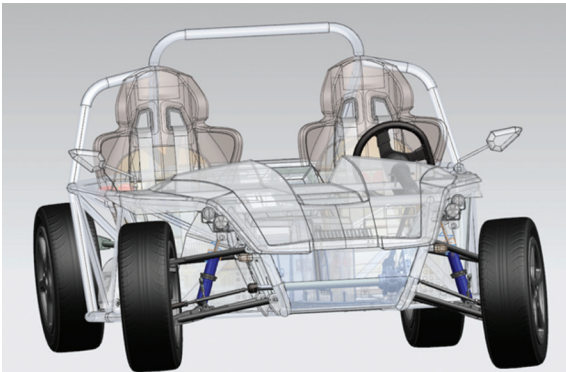

Module benefits

- Achieve highly accurate simulations (displacements, velocities, accelerations, reaction forces, flexible body results) using advanced multibody dynamics solving techniques
- Reduce costly physical prototypes by using motion simulation to understand mechanism performance

Key features

- Analysis types include kinematic, dynamic, static, quasi-static, time and step, articulation (interactively driven), spreadsheet (driven via a live Excel spreadsheet software table)
- An efficient set of sparse matrix algorithms to solve the linear equations formed in each type of analysis
- Explicit and implicit numerical integrators
- Support for model exchange and co-simulation
- User-defined subroutines
- The Simcenter 3D Motion solver four node allows customers to share solver licenses over multiple cores and machines. It provides the advantage of sharing licenses of some add-on modules across cores and machines

Simcenter 3D

Motion Model Export

Simcenter 3D Motion Model Export is the gateway to exporting models for both effortless model sharing as well as real-time simulation purposes. After the model is exported in the user selected format, the resulting model files can be used without a runtime license on real-time (RT) applications and/or integrated with other multi-physics models. This freedom allows easy sharing and operation of exported Motion models across departments. The ability to reuse existing validated model supports the industry goals to have a single source of modeling.

The exported models are solved using the Simcenter 3D Motion fixed-step Real-Time solver. This allows the reuse of existing and complex models for RT simulators and hardware-in-loop tests that require hard RT solving.

Module benefits

- Re-use Simcenter 3D Motion models in real time instead of recreating multiple models
- Avoid reducing models and maintain the original DOF
- License-free runtime after export to promote model sharing and easy usage

Key features

- Real-time performance is possible
- Fixed step solution
- Flexible body support
- Support for Real-time platforms; Concurrent, dSPACE, Procyon, Windows 64, Linux 64 variants
- Support for FMI
- Support for Matlab Simulink

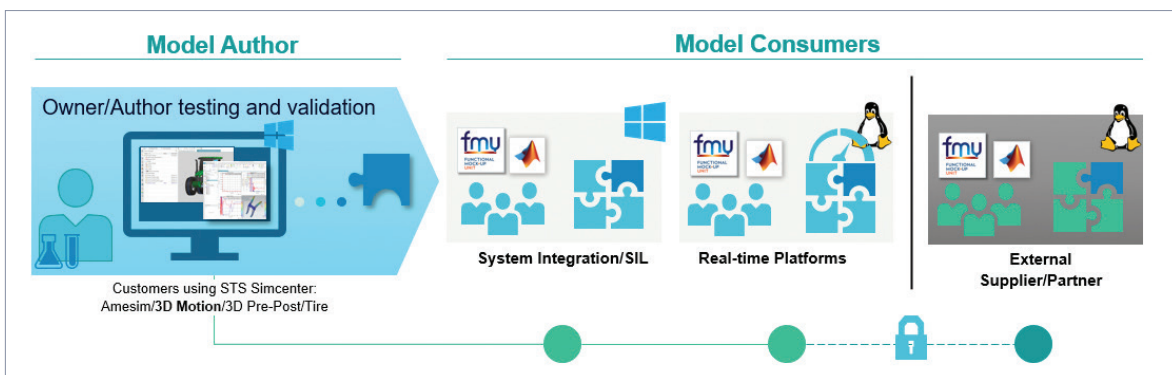

Simcenter 3D Motion Systems and Controls

Mechanical engineers can easily predict how control systems affect their mechanisms, and control engineers can optimize their system designs with Simcenter 3D Motion Systems and Controls. This module provides a library of control modeling elements for the dynamic simulation of mechatronic systems. Through an interface to the MATLAB® environment and the Simulink® environment, you can easily connect motion models directly with control system designs to co-simulate both the motion and control models simultaneously. Simcenter 3D Motion Systems and Controls also includes a generic cosimulation interface for interfacing with other third- party or inhouse codes as well as a Functional Mockup interface (FMI) that enables you to create FMI units that contain the model structure, variables, parameters, inputs, outputs and functionality of your original model. Then enables you to export/import simulation models between software packages.

Module benefits

- Reduce risks from early design phases and gain engineering insight by correctly simulating the combined mechatronic system
- Design accurate and robust actuators and controllers

Key features

- Embedded library of control modeling elements including 2D graphical view of control block diagram
- Variable step solution
- Support for FMI
- Interface to Simcenter Amesim, MATLAB or Simulink for simulation of full nonlinear mechanical systems, including complex control and actuators

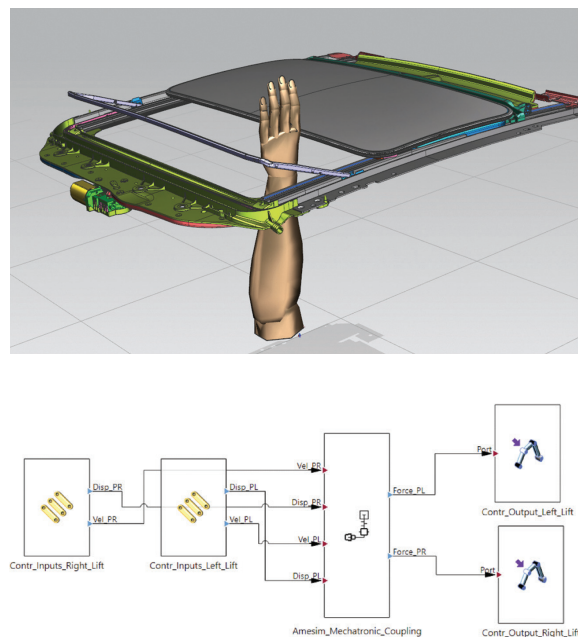
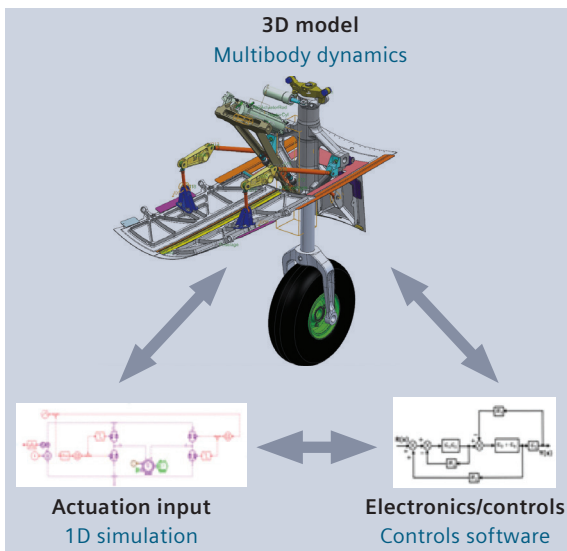

Simcenter 3D

Motion Flexible Body

Using Simcenter 3D Motion Flexible Body helps increase the accuracy of multibody models by considering component deformations when simulating the motion of mechanisms. This approach allows you to combine the standard multibody simulation technology with a representation of body flexibility using a set of deformation modes.

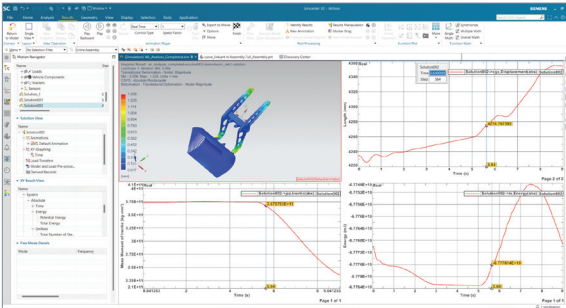
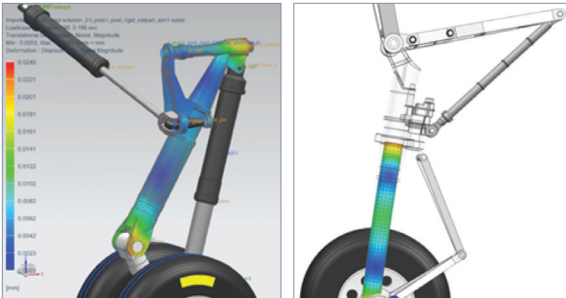

Module benefits

- Increase the accuracy of the predicted motion of mechanisms with flexible components
- Accurately predict the structural behavior of a body based on exact loads from connections in a mechanism

Key features

- Component mode synthesis methods available with multiple FE solvers such as Simcenter Nastran® software, MSC Nastran, ANSYS and Abaqus
- Editing of flexible body properties: mass and moments of inertia, modal damping

Simcenter 3D

Motion Flexible Body Advanced

Using Simcenter 3D Motion Flexible Body Advanced extends modeling by using an automated process to turn existing geometry into a flexible body for motion analysis. It also allows you to model constraints and contact forces applied to flexible bodies.

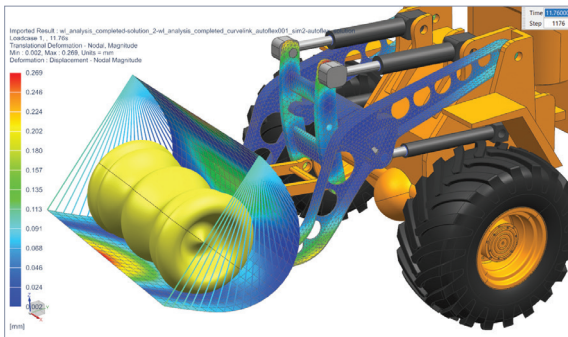

Module benefits

- Simplify the flexible body modeling process with time-saving guided procedures
- Facilitate simulation of distributed loads on flexible bodies due to contacts

Key features

- Automatic flex tool: It takes only a few mouse clicks to go from existing CAD geometry to a complete flexible body with associative finite element (FE) mesh representation and proper boundary conditions based on the connections to the mechanism
- Contact forces on flexible bodies: rigid-to-flex, flex-to-flex
- Point-on-curve constraints extended to flexible curves defined on FE nodes

Simcenter 3D

Motion Standard Tire

Using Simcenter 3D Motion Standard Tire enables you to model any force component generated by a pneumatic tire in contact with a road surface, including normal and vertical, longitudinal and lateral, as well as all resulting moments.

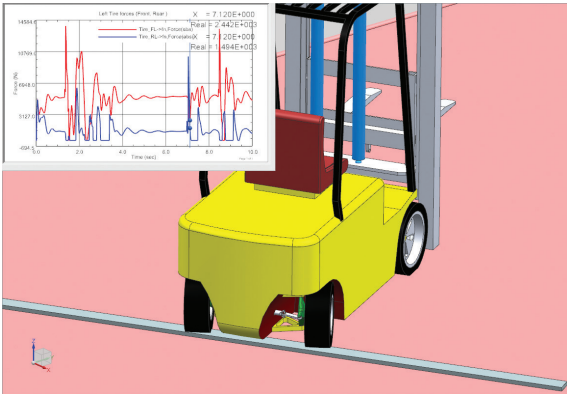

Module benefits

- Accurate prediction of tire-road interactions for CAE based driving dynamics assessment
- Predict ride comfort and handling performance of a vehicle with a limited number of tire and road parameters

Key features

- Access multiple tire force models with a scalable level of detail; suitable models for passenger cars, trucks and buses, agriculture and construction equipment vehicles and landing gear
- Perform high-frequency analyses, such as full-vehicle ride comfort behavior and durability analysis
- Includes three tire formulation models: noninertial, basic and motorcycle

Simcenter Tire

Accurately represent tire performance to predict important vehicle aspects such as directional stability, braking distance, and ride comfort. Using Simcenter Tire enables engineers to effectively and precisely model the highly non-linear tire component. This will allow them to analyze the vehicle behavior better and earlier, reducing development time.

Using Simcenter Tire includes the MF-Tyre/MF-Swift tire model, the MF-Tool tire model parameter tool and tire testing and engineering services. By combining those elements, Simcenter can deliver customized tire modeling methodologies, providing the optimal balance between simulation accuracy and cost-efficiency. The solution has proven success with numerous vehicle OEMs around the globe.

Read the [Simcenter Tire fact sheet](#) for more information.

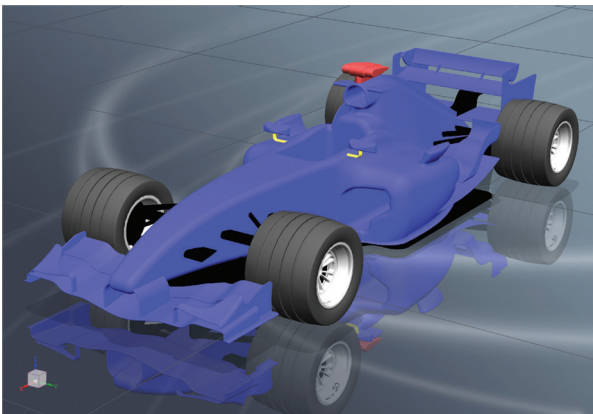

Module benefits

- Simulate tire forces for assessing vehicle handling and controlling prototyping analyses
- Accurately predict vehicle handling behavior, including steady-state cornering, power-off in a turn, lane change, J-turn and more

Key features

- Model the steady-state and dynamic behavior of the tire within a frequency band that covers vehicle handling analyses, as well as control prototyping and rollover simulations
- Simulate vehicle control systems such as antilock braking system (ABS), electronic stability control (ESP), vehicle dynamic control (VDC) and traction control system (TCS)



Simcenter 3D Motion Drivetrain

Simcenter 3D Motion Drivetrain bundles functionality to create transmissions, chains, belts and tracks. This is done through a dedicated interface for transmission creation (Transmission Builder) and the mechanism replication tool (Discrete Drivetrain).

Transmission Builder is an easy to use, in-depth, gearbox specific, multi-body simulation process. That allows engineers to move rapidly from the initial design specifications to an accurate simulation.

The Discrete Drivetrain can replicate a user created mechanical segment along a path. This convenient interface simplifies the modelling of chains, belts and track systems.

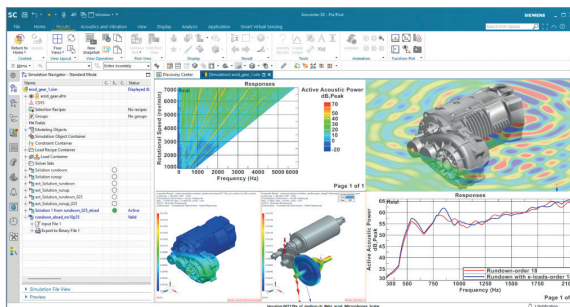

Module benefits

- Automatically create multibody transmission models based on industry standards, reducing model creation time by up to 80 percent
- Perform end-to-end transmission simulation processes in a single environment
- Achieve reliable and fast multibody gear simulations with validated advanced solver methodologies
- Facilitate a robust layout algorithm with a discrete drivetrain to simplify the modeling of chains, belts and tracked systems with customized geometries
- Gain insight into the complex dynamics of chains, belts and tracked systems to improve performance

Key features

- Automated multibody model creation for transmissions based on industry standards
- Manages both cylindrical and spatial gear systems. For cylindrical gears, single, multi-stage spur and helical assemblies both external and internal (such as in planetary systems) gears are supported. For bevel gears, straight bevel and spiral bevel gears are supported (such as in differentials and rear axle drivelines)
- Direct link to Simcenter 3D Acoustics to perform noise, vibration and harshness (NVH) assessment
- Define any pattern body with custom geometry such as chain links and track segments together with their connecting joints and forces
- Define layout components based on user-defined topology
- Predict the transient dynamic response – displacement, velocity, acceleration and loads on all pattern bodies and the related layout components

Capabilities chart

NX and Simcenter 3D Motion capabilities

General capabilities	Specific capabilities												
		NX Motion	Simcenter 3D Motion Modeling	Simcenter 3D Motion solver	Simcenter 3D Motion Systems and Controls	Simcenter 3D Motion Flexible Body	Simcenter 3D Motion Flexible Body Advanced	Simcenter 3D Motion Tire	Simcenter Tire	Simcenter Motion Drivetrain	Simcenter 3D Motion Model export	RT solver Node locked	Simcenter 3D Motion Solver 4-node
Modeling	Import of animation designer, assembly constraint and Tecnomatix® portfolio process simulate kinematics models	•	•										
	Association to part and assembly geometry	•	•										
	Quick creation of primitive graphics	•	•										
	Joints, couplers, constraints	•	•										
	Motion drivers	•	•										
	Spring/damper and bushings	•	•										
	Applied forces	•	•										
	Joint friction	•	•										
	Initial conditions	•	•										
	3D body contact and analytical contact	•	•										
	Submechanisms	•	•										
	Text based elements		•										
	Integration with Simcenter Amesim™ software		•										
Postprocessing	Animation	•	•										
	XY graphing	•	•										
	Motion envelope, interference check, point trace, animation camera, load vectors	•	•										
	Capture assembly arrangements during animation	•	•										
	Multiple load case support	•	•										
	Load transfer to Simcenter 3D Engineering Desktop	•	•										
	Multiple output formats (the JT™ data format, VRML, animation movies, etc.)	•	•										
Analysis types and solver capabilities	Static equilibrium	•	+	•									
	Kinematic simulation	•	+	•									
	Dynamic simulation	•	+	•									
	Driver control through articulation and spreadsheet	•	+	•									
	User defined forces and subroutines		+	•									
	Multi-processor batch solver		+	+									•
	Real time solver		+	+						+	•		
Controls	Integration with Matlab		+	+	•								
	Integration with FMI/FMU 1.0 and 2.0		+	+	•								
	Integration with generic co-simulation		+	+	•								
	Control operations		+	+	•								

General capabilities	Specific capabilities	Specific capabilities											
		NX Motion	Simcenter 3D Motion Modeling	Simcenter 3D Motion solver	Simcenter 3D Motion Systems and Controls	Simcenter 3D Motion Flexible Body	Simcenter 3D Motion Flexible Body Advanced	Simcenter 3D Motion Tire	Simcenter Tire	Simcenter Motion Drivetrain	Simcenter 3D Motion Model export	RT solver Node locked	Simcenter 3D Motion Solver 4-node
Flexible bodies	Linear flexible bodies		+	+		•							
	Automatic flexible body creation		+	+		+	•						
	Flexible body contact		+	+		+	•						
	Flexible body point-line constraint		+	+		+	•						
Drivetrain	Powertrain (combustion, tachometer, HD bearings)		+	+					•				
	Chains and Belts – timing or accessory		+	+					•				
	Transmission builder vertical and gear contact		+	+					•				
Vehicles	Tire Modeling of handling and primary ride (<5Hz)		+	+				•	•				
	Tire modeling of secondary Ride (< 25Hz)		+	+					•				
	Tire modeling of Harshness & durability (<100 Hz)		+	+					•				
	Track vehicles		+	+					•				

Legend:

- = included in module
- + = prerequisite

Note: Simcenter 3D Engineering Desktop is a minimum prerequisite for all Simcenter 3D products. Other dependency or prerequisites may apply for individual products.



DIGITAL INDUSTRIES SOFTWARE

Simcenter 3D for thermal multiphysics simulation

Facilitating the modeling of nonlinear and transient heat transfer phenomena

Solution benefits

Leverage the Simcenter 3D integrated environment to make quick design changes and provide rapid feedback on thermal performance

Accurately solve the Navier-Stokes equations that describe fluid motion

Perform conjugate heat transfer analysis on complex models using the imbedded CFD solver

Use Simcenter Nastran to understand thermoelastic effects with coupled physics analysis

Minimize tedious rework and modeling errors with direct interfaces for ECAD systems

Predict thermal performance for orbiting vehicles accurately and quickly

Increase collaboration and team productivity with a thermal multiphysics analysis solution that is easily integrated with your design and engineering process

Simcenter™ 3D software offers a complete solution for modeling nonlinear and transient heat transfer phenomena, accounting for conduction, convection, radiation and phase change. Dedicated thermal modeling capabilities are available, such as rapid thermal connection methods, an extensive physical model library and a wide array of thermal loads and boundary conditions. The integrated CFD solution enables fast and accurate fluid flow simulation

with tight coupling to the thermal model for conjugate heat transfer analysis of products at all design development phases, limiting costly, time-consuming physical testing cycles. These tools provide flexibility and ease-of-use while addressing complex thermal challenges.



Thermal

SIEMENS

[siemens.com/simcenter3d](https://www.siemens.com/simcenter3d)

Simcenter 3D for thermal multiphysics simulation

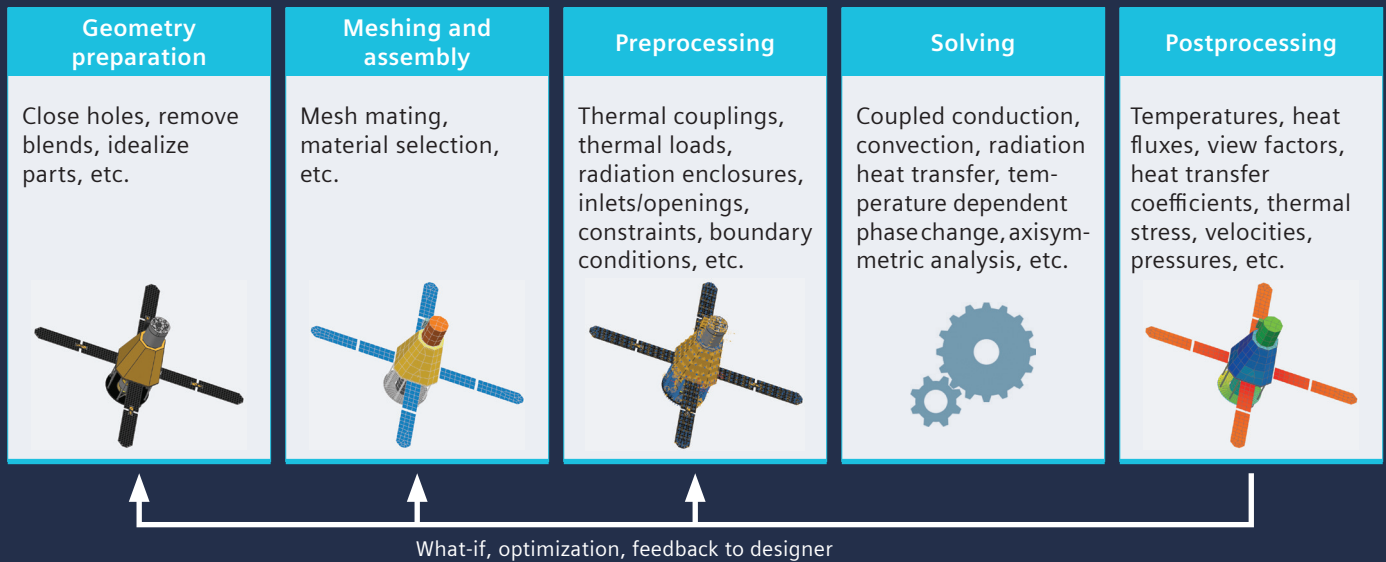

Gain reliable thermal and flow insights

A pioneering tool in computational heat transfer modeling, Siemens Digital Industries Software's Simcenter 3D Thermal Multiphysics has been continuously developed for over three decades. It boasts a complete element, material and physical model library that is linked to enriched, high-fidelity solvers with a broad set of functionalities. This is further enhanced by intuitive pre-/postprocessing functionalities for thermal, flow and multi-physics analysts.

Easily handle thermal exchange between dissimilar interfaces

Using Simcenter 3D, thermal connections can be automatically defined between disjoint components, dissimilar meshes and nonconforming geometry. Moreover, mesh congruence and proximity requirements are eliminated, which enables the user to build and solve large assemblies quickly.

Rapid creation and easy management of fluid domains

Automatic and rapid extraction of the fluid domain using traditional Boolean operations, surface wrapping, or defining immersed bodies helps improve CFD analysis productivity. Simcenter 3D can automatically join dissimilar fluid meshes at interfaces between different parts, which allows the user to quickly investigate many "what-if" simulation scenarios involving complex assemblies. All parts within any design

assembly context can be meshed independently. The resulting disjoint fluid faces can be connected to form a single fluid domain at solve time. Individual part changes can be re-integrated quickly within the assembly mesh, thereby avoiding the time-consuming task of remeshing the entire assembly.

Master complexity and productivity in industry verticals

The capabilities of Simcenter 3D for thermal simulation have been leveraged in vertical applications to satisfy specific industry needs. Simcenter 3D Space Systems Thermal enables the user to model the thermal performance and characteristics of orbiting and interplanetary vehicles. Simcenter 3D Electronics Systems Cooling leverages the flow and thermal solvers as well as the NX™ PCB Exchange capabilities in an integrated multiphysics environment to simulate 3D air flow and thermo-fluid behavior in densely packed, heat-sensitive electronic systems.

Automation and customization to manage a wide range of models

Simcenter 3D for thermal multiphysics provides an extensible solver architecture supporting user subroutines, user plugins, expressions and an open application programming interface (API) to automate and customize the product development workflow according to industry needs.

Providing a platform for multidiscipline simulation

The Simcenter 3D Thermal Multiphysics solution is part of a larger, integrated multidiscipline simulation environment with Simcenter 3D Engineering Desktop at the core for centralized pre-/postprocessing for all Simcenter 3D solutions. This integrated environment helps you to achieve faster CAE processes and streamline multidisciplinary simulation such as thermomechanical analyses based on structural solutions, conjugate heat transfer problems that are coupled with flow solutions, and coupled thermal-flow-structural problems where all three physics are intricately tied together.

Industry applications

Thermal multiphysics applications in Simcenter 3D include simulation and analysis for a range of heat transfer and fluid flow problems in aerospace, automotive, electronics, power generation, process and other industries.

Automotive and transportation

Simcenter 3D helps tackle a variety of analysis scenarios, such as under-hood thermal analysis (including porous blockage models), powertrain thermal management and thermal response and temperatures in automotive lighting systems. Further automotive applications include thermal management in automotive lighting systems, cabin comfort and humidity analysis, gas mixture modeling of exhaust and pollutant species transport. Simcenter 3D offers a complete solution for the thermal design of electric vehicles, including batteries and enclosures.

Aerospace and defense

Simcenter 3D includes the ability to model the thermal response from a single component to a global aircraft system. Transporting humidity along with film condensation modeling, can be used to obtain estimates of passenger comfort. The aero-engine turbine, compressor and entire engine may be modeled for a thermal analysis or a coupled thermomechanical analysis with Simcenter Nastran® software. Thermal dissipation from electrical components can be modeled using the nonlinear Joule heating capability. Aerothermal or ablation analysis is an area of strength.

Electronics and consumer goods

Simcenter 3D can be leveraged to meet the design requirements of compact and complex electronics systems. Examples include identifying recirculation zones and hot spots, predicting thermal response based on spatially varying and orthotropic conductivity and capacitance, and determining cooling strategies and heat sink modeling. Humidity and film condensation on electronics components can be readily simulated.

Industrial machinery

Simcenter 3D can be used to simulate a broad category of applications such as laser ablation and cutting, welding thermal response, mold-cooling analyses and phase change thermal analysis. Flow in rotating machinery can be modeled using the rotating frame of reference method with convection to both 2D axisymmetric and 3D meshes supported. In the cold-chain industry, Simcenter 3D can be used for performing predictive modeling of the quality of frozen and temperature-sensitive materials during shipping and handling. Two-phase flow conditions, with constituents having significantly different densities and viscosities, are also supported.

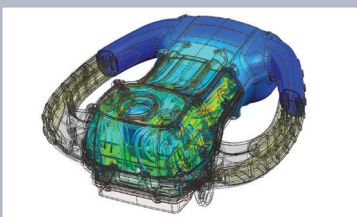
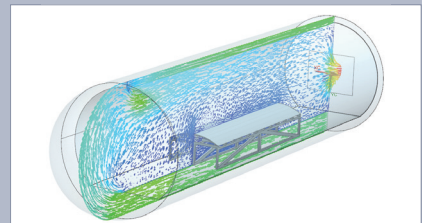
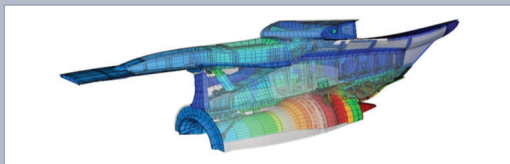

Whole engine thermomechanical
 Spacecraft thermal performance
 Electronics cooling
 Orbital heating
 Powertrain thermal management
 Cabin comfort
 Cold chain

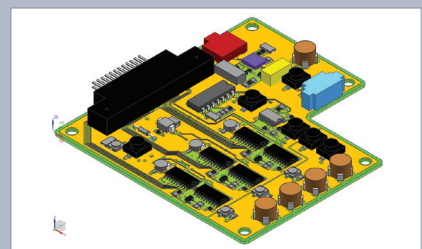

Simcenter 3D Thermal Multiphysics

Thermal

Simcenter 3D Thermal provides heat transfer solutions and can simulate conduction, convection and radiation phenomena for complex products and large assemblies. A wide range of methods are available for sophisticated radiation analysis, advanced optical properties, radiative and electrical heating models, one-dimensional hydraulic network modeling and advanced material models such as phase change, charring and ablation. Thermal control devices and articulation may also be modeled. The Simcenter 3D Thermal solver is based on a finite-element, finite-volume formulation to simulate heat transfer phenomena accurately and efficiently.

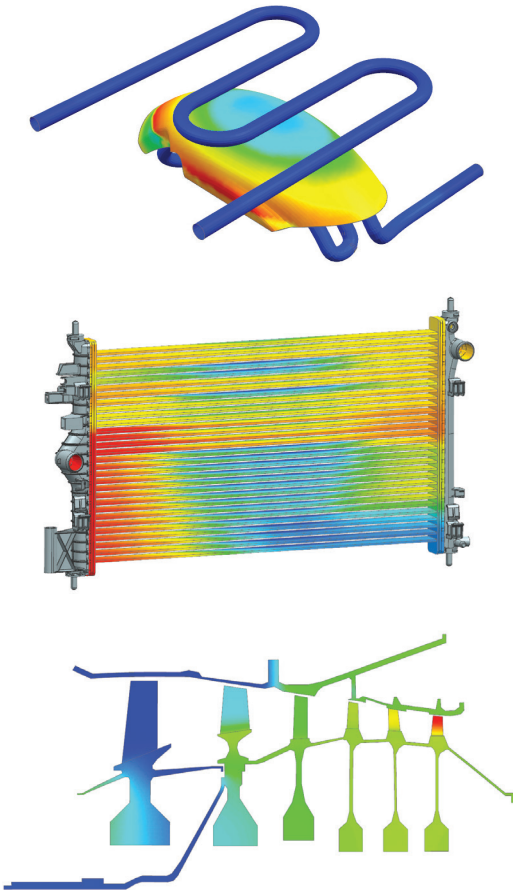

Module benefits

- Solve complex heat transfer phenomena with a comprehensive set of modeling tools
- Leverage open architecture to integrate user subroutines and grant greater control over the solution
- Use parallelized thermal solver and view factor calculations (with GPU support) to increase solution efficiency and reduce total run time
- Use Simcenter Nastran software to understand thermomechanical effects of coupled physics analysis
- Deliver full assembly finite element method (FEM) support to model complex systems

Key features

- Fully coupled conduction, radiation and convection heat transfer simulation to steady-state and transient problems
- Axisymmetric modeling, streamlined 2D-3D modeling and nonlinear thermal properties
- Thermally connect disjoint and dissimilar mesh faces and edges
- Live results post-processing & solver parameters control during solve
- Advanced radiation methods such as deterministic and Monte Carlo ray tracing and nongray multiband radiative heat transfer
- Dedicated turbomachinery-specific boundary conditions combining ducts and streams
- Seamlessly submit simulations to powerful remote machines using the integrated Simcenter 3D Remote Simulation capability

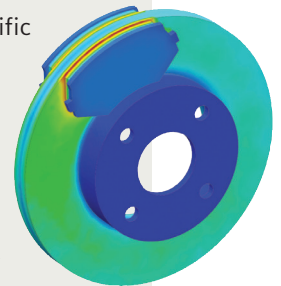

Simcenter 3D

Thermal Multiphysics Flow

Simcenter 3D Thermal Multiphysics has a computational fluid dynamic (CFD) solution that provides sophisticated tools to model and simulate fluid flow for complex parts and assemblies. It combines the power and accuracy of the well-established control-volume formulation with cell-vertex formulation to discretize and efficiently solve the fluid motion described by the Navier-Stokes equations. The capabilities encompass internal or external fluid flow, including compressible flows, non-Newtonian fluids, tracking of heavy particles and multiple rotating frames of reference.

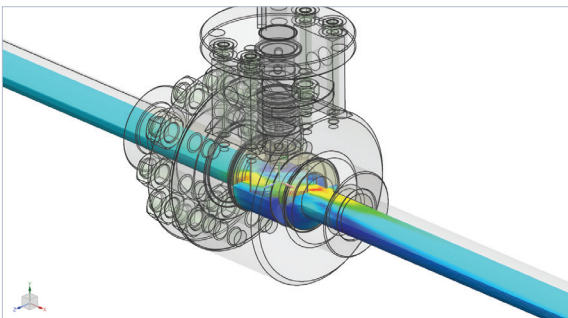
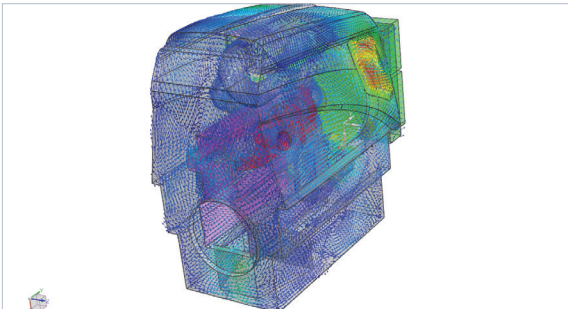
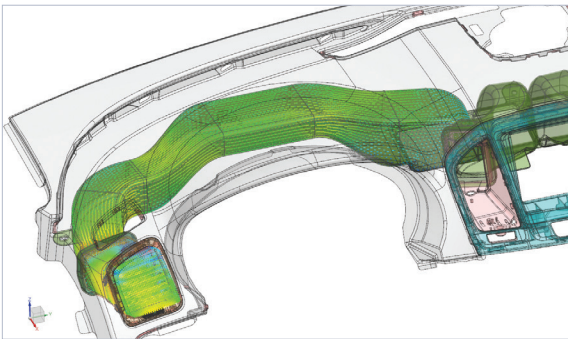

Module benefits

- Reduce costly physical prototypes by simulating fluid flow in a virtual environment
- Streamline processes that require a multi-disciplinary simulation approach
- Save time and avoid errors due to transfer of data and results for multiphysics simulation
- Efficient and accurate rotating machinery simulation
- Couple 1D hydraulic networks with 3D flow models to simulate complex systems

Key features

- Simulate internal- or external-flow problems in turbulent, laminar and mixed flows
- Account for forced, natural and mixed convection
- Connect dissimilar fluid meshes at interfaces between complex assemblies
- Live results post-processing & solver parameters control during solve
- Industry-standard turbulence models such as RNG k-epsilon, Realizable k-epsilon, SST, k-omega and LES are supported
- Seamlessly submit simulations to powerful remote machines using the integrated Simcenter 3D Remote Simulation capability

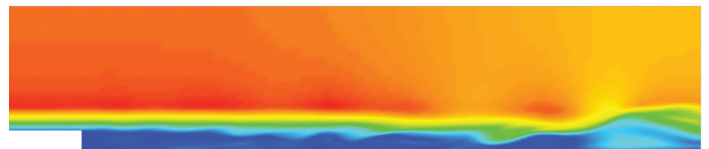

Simcenter 3D

Space Systems Thermal

Simcenter 3D Space Systems Thermal is the vertical application that provides a comprehensive set of tools to perform orbital thermal analyses in the Simcenter 3D environment. Simcenter 3D Space Systems Thermal helps resolve engineering challenges early in the design process and is a valuable tool for predicting and understanding thermal physics for space-bound, orbiting and interplanetary vehicles.

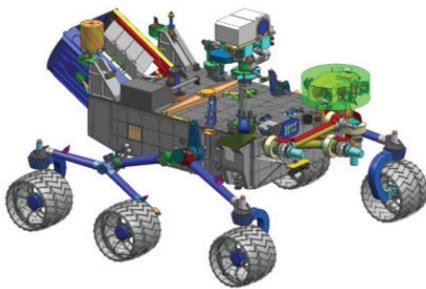

Module benefits

- Predict thermal performance for orbiting vehicles accurately and quickly
- Increase collaboration and team productivity with a thermal analysis solution that is easily integrated with your design and engineering process
- Maximize process efficiency with a highly automated solution that requires no additional input files and carries out the analysis in a single pass

Key features

- Model orbital heating for all planets of the solar system
- Transient view factor recalculations with articulating geometries such as sun-tracking solar panels and directional antennas
- Support for advanced thermo-optical properties, including angle and spectral dependencies
- Accurate modeling of solar radiation that accounts for atmospheric effects such as turbidity, and ground reflection and shadowing
- Multilayer shell formulation for modeling multilayer insulation, composite panels and thermal protection systems
- View simulation results in the Orbit Visualizer for a clear view of the evolution of thermal characteristics over the course of the orbits
- Seamlessly submit simulations to powerful remote machines using the integrated Simcenter 3D Remote Simulation capability
- Accurate Printed Circuit Board models can be created using NX PCB exchange and used directly inside the spacecraft thermal model in Space Systems Thermal

Simcenter 3D

Electronic Systems Cooling

Simcenter 3D Electronic Systems Cooling software is an industry-specific vertical application that leverages Simcenter 3D Thermal Multiphysics solvers as well as NX™ software and the NX PCB Exchange module capabilities in an integrated multiphysics environment. This enables you to simulate 3D airflow and thermofluid behavior in densely packed, heat-sensitive electronic systems.

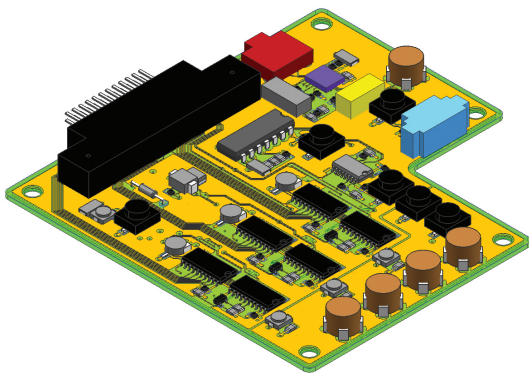
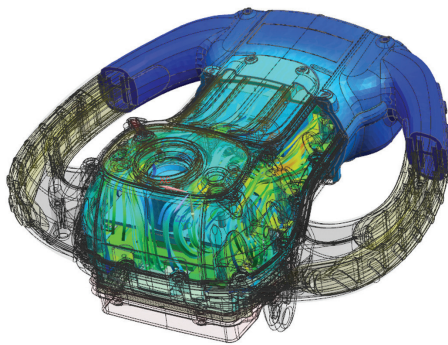

Module benefits

- Simulate 3D airflow and thermal behavior in electronic systems
- Minimize tedious rework and modeling errors with direct interfaces to electrical computer-aided design (ECAD) systems
- Transport condensation, humidity and dust particles in electronics systems

Key features

- With NX PCB Exchange, fully three-dimensional board designs can be obtained from the leading printed circuit board (PCB) and flexible printed circuit (FPC) layout software packages from companies such as Expedition, Zuken, Cadence and Altium
- Model the electrical network along with Joule heating with temperature-dependent resistivity
- A catalog of fan curves is available out-of-the-box (OOTB), which can be extended with additional manufacturer data

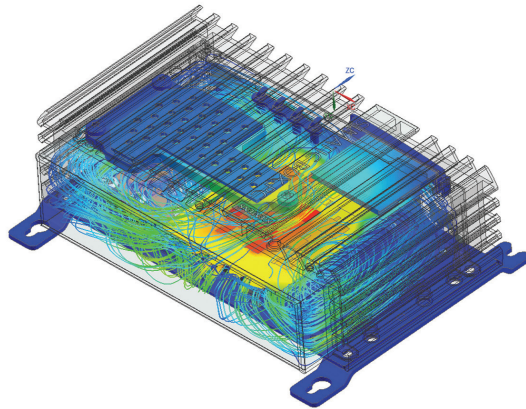

Simcenter 3D

Thermal Multiphysics HPC

Simcenter 3D Thermal Multiphysics high-performance computing (HPC) leverages hardware systems configured as a multiprocessor desktop or a multi-node cluster. One license of Simcenter 3D Thermal/Flow DMP together with the prerequisite licenses can be used to produce a solve over as many processors as available, or to compute very quickly radiation view-factor using Nvidia GPUs.

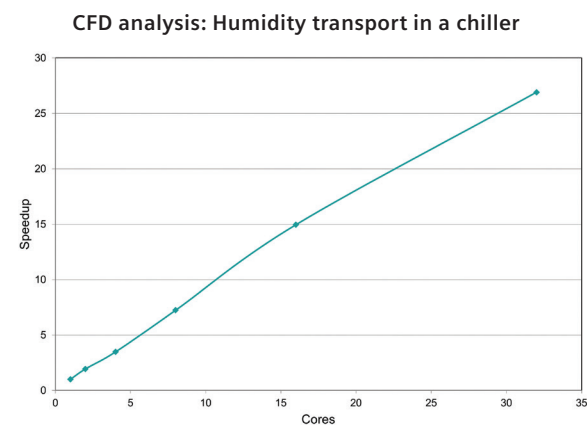
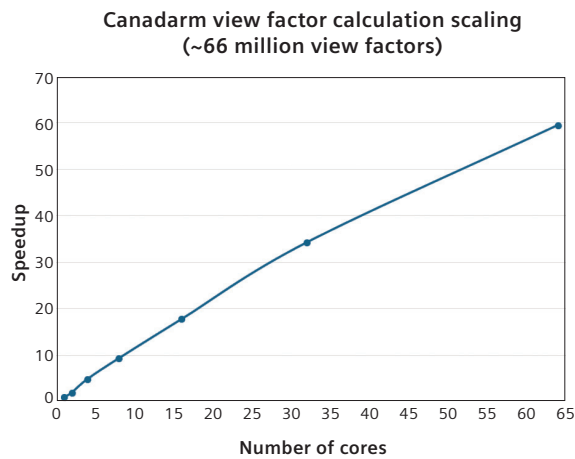

Module benefits

- Leverage the flexibility of solving on a single machine or across a distributed network or cluster
- Maximize the value of your hardware investments and greatly improve your solution

Key features

- Cores may be co-located on a single workstation, distributed over a local area network (LAN), or exist within a standalone computational cluster
- Limitations on the maximum number of cores are eliminated, allowing solve speeds to scale up or down based on the number of available cores, not the number of available licenses
- Domain decomposition techniques are included for solving large-scale thermal models and flow models
- The Simcenter 3D Thermal Multiphysics solver features parallel computation of radiation view factors, radiative heating and a solution for the thermal model
- Enables GPU-based view factor computation and ray tracing for rapid radiative heat transfer computations

Capabilities chart

General capabilities	Specific capabilities	Simcenter 3D Thermal Multiphysics			
		Simcenter 3D Thermal Multiphysics	Simcenter 3D Space Systems Thermal	Simcenter 3D Electronics Systems Cooling	Simcenter 3D Thermal Multiphysics HPC
Solver(s)	DMP thermal parallel processing	+	+	+	•
	DMP flow parallel processing	+		+	•
	Thermal parallel processing	+	+	+	•
	Flow parallel processing	+		+	•
	Multiphysics solve	+	+		
	Multithreading	•	•	•	
	User subroutine	•	•	•	
	User plugin	•	•	•	
File export	cgns	•		•	
	esatan		•		
	INPF	•	•	•	
	Mapping constraint primitive	•	•	•	
	Sinda-85		•		
File import	cgns	•		•	
	I-DEAS scratch file	•	•	•	
	INPF	•	•	•	
	NX xml	•	•	•	
	plot3d	•		•	
	primitive		•		
	Universal	•	•	•	
Modeling objects	Ablation charring	•	•		
	Active heater controller	•	•	•	
	Advanced parameters flow	•		•	
	Advanced parameters thermal	•	•	•	
	Axisymmetry source zone (multiphysics only)	•			
	Convection properties	•		•	
	Duct convection correction	•	•		
	Duct head loss	•	•		
	External conditions	•		•	
	External solver	•			
	Fan speed controller	•		•	
	Generic entity	•	•	•	
	Homogeneous gas mixture	•		•	
	Immiscible fluid mixture	•		•	
	Joint	•	•		
	Joint orbital tracker		•		
	Layer	•	•	•	
	Monte Carlo settings	•	•	•	
	Multiphysics thermal output request	•			
	Nongeometric element	•	•	•	

General capabilities	Specific capabilities	Simcenter 3D Thermal Multiphysics				
		Simcenter 3D Thermal Multiphysics	Simcenter 3D Space Systems Thermal	Simcenter 3D Electronics Systems Cooling	Simcenter 3D Thermal Multiphysics HPC	
Modeling objects (continued)	Non-Newtonian fluid	•		•		
	Orbit		•			
	PCB layer		•	•		
	PCB via		•	•		
	Planar head loss	•		•		
	Reference temperature	•	•	•		
	Rotational periodicity source zone (multiphysics only)	•	•			
	Target temperature	•	•	•		
	Target temperature change	•	•	•		
	Thermal solution parameters (multiphysics only)	•	•			
	Thermal source zone (multiphysics only)	•				
	Thermo optical properties	•	•	•		
	Thermo optical properties advanced	•	•	•		
	Thermo optical properties state	•	•	•		
	Thermostat	•	•	•		
	Tracer fluid	•	•	•		
	Advanced Fluid Modeling required during solve as well	3D Hybrid mesh	•		•	
		Constraint - auto refinement	•		•	
		Constraint - contact prevention	•		•	
		Constraint - local resolution	•		•	
Boundary layer mesh control		•		•		
CGNS import / export		•		•		
PLOT3D import		•		•		
Sim fluid domain SSSO		•		•		
Sim fluid domain mesh		•		•		
Recipe create (output body)		•		•		
Recipe create (output body + 2D mesh)		•		•		
Recipe create (output 2D mesh)		•		•		
Recipe create from 2D element faces		•		•		
Tet Mesh (with BL mesh control)		•		•		
WRAP (output body)		•		•		
WRAP (output body + 2D mesh)		•		•		
WRAP (output 2D mesh)		•		•		
WRAP recipe with constraints		•		•		
WRAP recipe from 2D element faces	•		•			

General capabilities	Specific capabilities	Simcenter 3D Thermal Multiphysics	Simcenter 3D Space Systems Thermal	Simcenter 3D Electronics Systems Cooling	Simcenter 3D Thermal Multiphysics HPC
Solution attributes and parameters	Fixed turbulent viscosity	•		•	
	Standard K-epsilon	•		•	
	RNG K-epsilon	•		•	
	Realizable K-epsilon	•		•	
	K-Omega turbulence model	•		•	
	LES-Large eddy simulation	•		•	
	Mixing length	•		•	
	Laminar flow	•		•	
	Spalart-Allmaras	•		•	
	Shear stress transport (SST)	•		•	
Loads	Thermal loads (heat load, heat flux, heat generation)	•	•	•	
	Gravity (component, magnitude and direction)	•	•	•	
	Rotation (model subset and whole model)	•	•	•	
	Thermal convecting zone	•	•	•	
	Thermal loads (heat load, heat flux, heat generation)	•	•	•	
	Thermal stream	•	•	•	
	Thermal void	•	•	•	
Constraint	Axisymmetry target zone	•	•	•	
	Convection to environment	•	•	•	
	Initial conditions	•	•	•	
	Film cooling	•		•	
	Flow target zone	•		•	
	Mapping	•	•	•	
	Mapping target zone	•	•	•	
	Rotational periodicity target zone	•	•	•	
	Simple environment radiation	•	•	•	
	Symmetry target zone	•	•	•	
	Temperature	•	•	•	
	Thermal target zone	•	•	•	
	Transverse gradient target zone	•	•	•	
Simulation objects	Advanced controls	•	•	•	
	Deactivation set	•	•	•	
	Deactivation set advanced	•	•	•	
	Disjoint fluid mesh pairing	•		•	
	Duct flow boundary condition	•	•	•	
	Flow blockage (porous, isotropic, orthotropic, solid)	•		•	
	Flow boundary condition				
	Bursting membrane	•		•	
	Convective outflow	•		•	
	Surface	•		•	
	Inlet	•		•	
	Internal fan	•		•	
	Opening	•		•	
	Outlet	•		•	
	Recirculation loop	•		•	
Static pressure	•		•		

General capabilities	Specific capabilities	Simcenter 3D Thermal Multiphysics	Simcenter 3D Space Systems Thermal	Simcenter 3D Electronics Systems Cooling	Simcenter 3D Thermal Multiphysics HPC
Simulation objects (continued)	Flow surface (boundary and embedded, with obstructions)	•		•	
	Fluid domain (fluid mesh and surface mesh)	•		•	
	Free molecular heating		•		
	Immersed boundary	•		•	
	Immersed ducts	•	•	•	
	Interface resistance	•	•	•	
	Joule heating (current, electrical coupling, voltage)	•	•	•	
	Merge set		•		
	Mixing plane (disjoint and joint)	•		•	
	Moving frame of reference (rotating and translating)	•		•	
	Orbital heating		•		
	Override set - thermal properties	•	•	•	
	Particle injection	•		•	
	PCB component		•	•	
	Periodic boundary condition (rotational and translational)	•		•	
	Printed circuit board		•	•	
	Protective layers	•	•		
	Radiation (all radiation and enclosure radiation)	•	•	•	
	Radiation thermal coupling (gap and object-to-object)	•	•	•	
	Radiative element subdivision	•	•	•	
	Radiative heating	•	•	•	
	Report	•	•	•	
	Screen	•		•	
	Selective results	•		•	
	Solar heating	•	•		
	Solar heating space	•	•		
	Solid motion effects (articulation, spinning)	•	•		
	Supersonic inlet	•		•	
	Symmetry plane	•		•	
	Thermal coupling	•	•	•	
	Thermal coupling – advanced	•	•	•	
	Thermal coupling – convection	•	•	•	
	Thermal coupling – radiation	•	•	•	
	Thermal devices (Peltier cooler, heat pipe)	•	•	•	
	Thermal rotational periodicity	•	•	•	
	Thermal streams junction	•		•	

General capabilities		Specific capabilities			
		Simcenter 3D Thermal Multiphysics	Simcenter 3D Space Systems Thermal	Simcenter 3D Electronics Systems Cooling	Simcenter 3D Thermal Multiphysics HPC
Catalogs	Advanced parameters	•	•	•	
	Component		•	•	
	Duct convection correction factors	•	•	•	
	Fan catalogs			•	
	Fan curves	•		•	

Legend:

- = included in module
- + = additional product required

Note: Simcenter 3D Engineering Desktop is a minimum prerequisite for all Simcenter 3D products. Other dependency or prerequisites may apply for individual products.

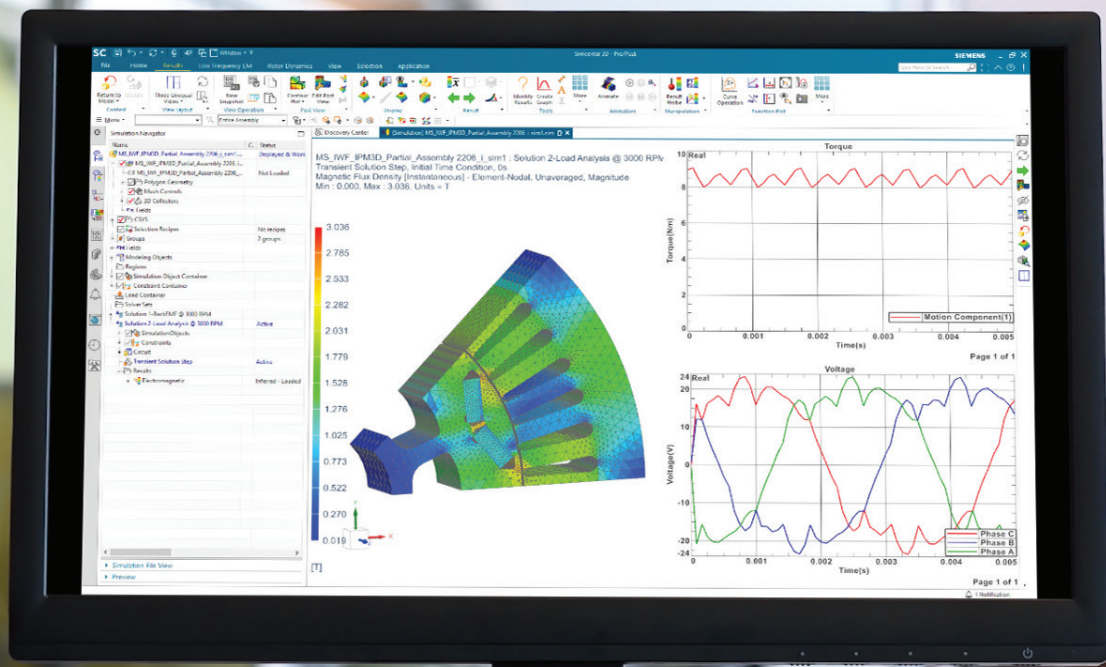

DIGITAL INDUSTRIES SOFTWARE

Simcenter 3D for electromagnetics simulation

Achieve optimized performance with electromagnetic and thermal simulations in your workflow using the Simcenter MAGNET solver integrated in Simcenter 3D

Solution benefits

Enable low-frequency electromagnetics simulation in a multidiscipline integrated environment

Accelerate design exploration through direct CAD integration, allowing extensive geometry parametrization

Leverage the Simcenter MAGNET solver to solve complex low-frequency electromagnetics models, including 3D models with complex motion

Simulate advanced material behavior such as permanent magnet demagnetization or hysteresis effects

Reduce development time with standardized workflows that enable efficient collaboration between electrical, mechanical and thermal teams

Simcenter™ 3D software for electromagnetics (EM) offers an integrated, low-frequency solver with Simcenter™ MAGNET™ software. Its comprehensive set of capabilities provides insight into diverse design challenges: performance of electromechanical components and energy conversion.

Analyze large-scale, system-level problems efficiently

Simcenter 3D for electromagnetics integrates capabilities that can generate, manage and simulate highly complex models in a reasonable amount of time and with minimal computational resources. There are efficient and effective methods tuned for low-frequency

applications such as e-machines, actuators, power transformers or electronics. Simcenter is a part of Siemens Xcelerator, a comprehensive and integrated portfolio of software and services from Siemens Digital Industries Software.

Dedicated and robust electromagnetic solvers

Simcenter 3D for electromagnetics is designed for robustness and computational efficiency. A range of dedicated solvers (finite elements magnetic and electric solvers with static, transient and time-harmonic variants for both 2D and 3D problems) with novel boundary conditions and smart mesh refinements offers a transformative computer-aided

SIEMENS

[siemens.com/simcenter3d](https://www.siemens.com/simcenter3d)

Simcenter 3D for electromagnetics simulation

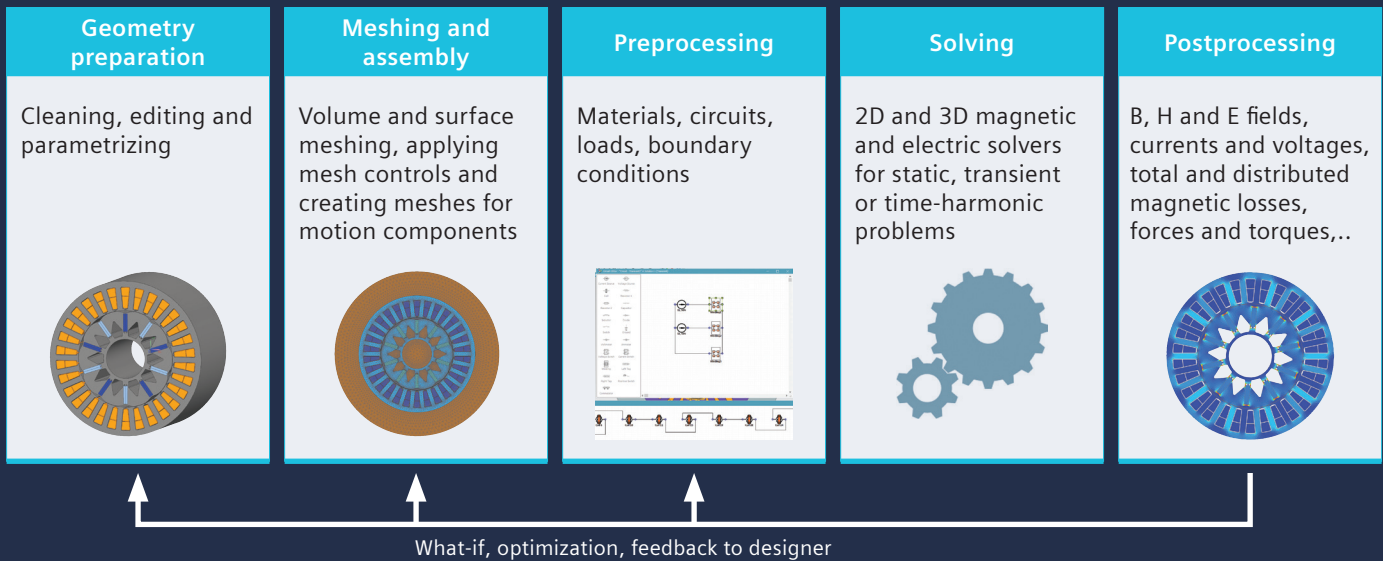

engineering (CAE) process, with simulations ranging from a fast, initial analysis to inherent realism for final verification.

Further refinement with integrated thermal simulations

Reliable and accurate results can only be obtained when models incorporate the right level of sophistication. Coupling high fidelity electromagnetic and thermal solvers facilitates realistic predictions of the temperature distribution and the corresponding effect on materials and low-frequency electromagnetic fields. This integrated thermal simulation provides further insights, ultimately resulting in reduced risk for demagnetization and performance drop.

Deliver high-fidelity simulations with advanced material models

The Simcenter 3D electromagnetics solution uses advanced algorithms to enhance readily available material data so simulation results strongly correlate with test data and expected performance. These capabilities include modeling manufacturing processes, temperature dependencies and magnetization imprints. Smart or engineered materials, which have uncommon electromagnetic properties, are modeled with high fidelity.

Providing a platform for multidiscipline simulation

The Simcenter 3D EM solution is part of a larger, integrated multidiscipline simulation environment with centralized pre- and postprocessing for all Simcenter 3D solutions. This integrated environment helps you achieve faster CAE processes and streamline multidiscipline simulations that integrate electromagnetics and other disciplines like noise, vibration, and harshness (NVH) and computational fluid dynamics (CFD). Thanks to the geometry associativity, design changes are quickly propagated to your CAE models, which update automatically and help engineering teams to be kept in synch with design changes, fostering collaboration. This allows you to generate a high-fidelity comprehensive digital twin and examine all core physics for product compliance, safety, and performance verification.



Electromagnetics

Industry applications

Electromagnetics heavily impacts product safety, performance and reliability, so having a comprehensive digital twin that can faithfully predict the multiple characteristics of this phenomenon is critical for design success.

Automotive and transportation

Simcenter 3D EM provides the tools for designing electric vehicles (EVs) and hybrid electric vehicle (HEV) powertrains and electromechanical components (pumps, actuators) or magnetic levitation motion for railway transportation.

Aerospace and defence

Simcenter 3D can tackle the complexity of designing and optimizing electrical components both for new electric propulsion systems as well as ancillary components such as heat pumps, transformers or electrical generators. The connection of Simcenter 3D with PLM solutions such as Teamcenter helps engineering teams to keep track of the design changes and accelerate the certification process.

Marine

Simcenter 3D can predict the performance of propulsion motors, energy storage systems and rails.

Industrial machinery

Simcenter 3D analyzes electromagnetic performance across multiple scales - from compact servo motors to MW-class generators, actuator or power and distribution transformers. The solution handles both component-level analysis and industrial process simulation such as induction heating, magnetic conveying or magnetic material sorting for recycling.

Consumer goods

Simcenter 3D analyzes electromagnetic performance across consumer electronics and appliances - from compact motors in household devices to personal e-mobility drives (e-bikes, scooters). The solution supports design optimization of domestic appliance components (pumps, fans, compressors), power electronics (converters, transformers), and wireless charging systems, helping to improve efficiency and thermal management.

Static, harmonic and transient low frequency field simulations

Coupled EM-thermal and EM-motion solvers

Complex 3D models with load driven motion

Advanced material modeling

CAD associated workflows

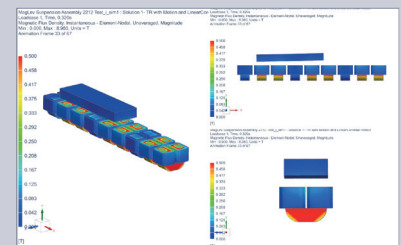
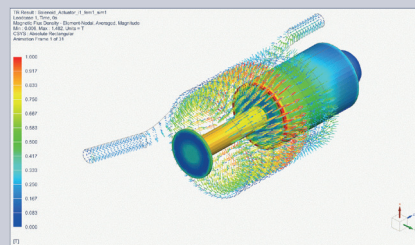
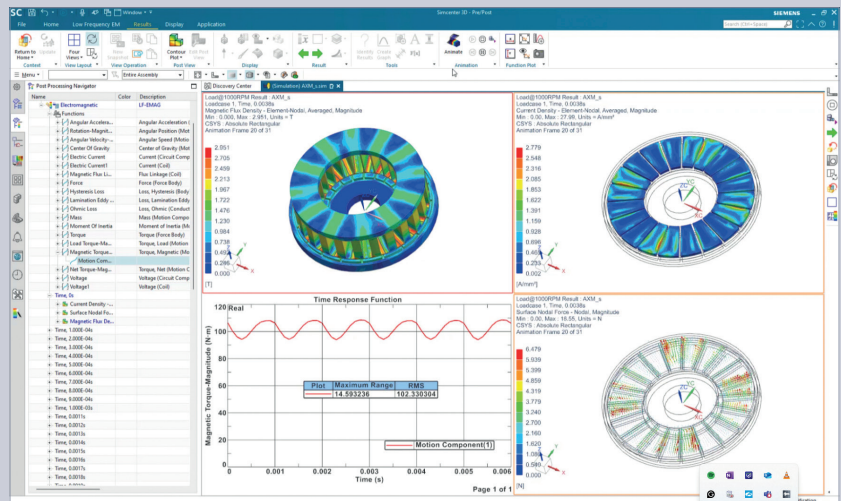

Simcenter 3D

Low Frequency Electromagnetics

Simcenter 3D Low Frequency EM software allows you to create and edit Simcenter MAGNET models. Using the Simcenter 3D graphical interface, you can import or build 3D electromechanical models in native Siemens NX™ CAD software, use and define sophisticated magnetic materials and define properties, boundary conditions and loads, including loads using an integrated 1D circuit modeling tool.

Once solved, the product allows you to dig deeper into the results and derive engineering insight to improve your design.

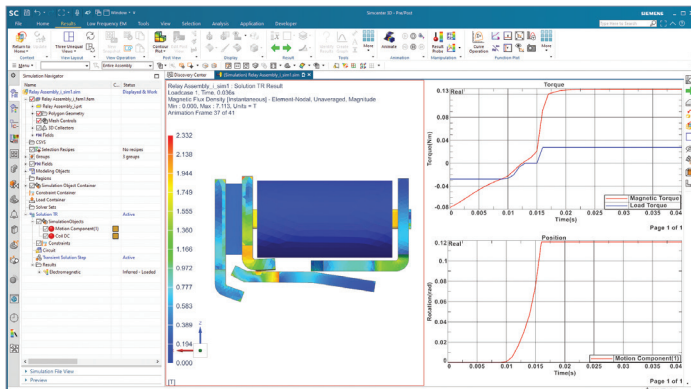
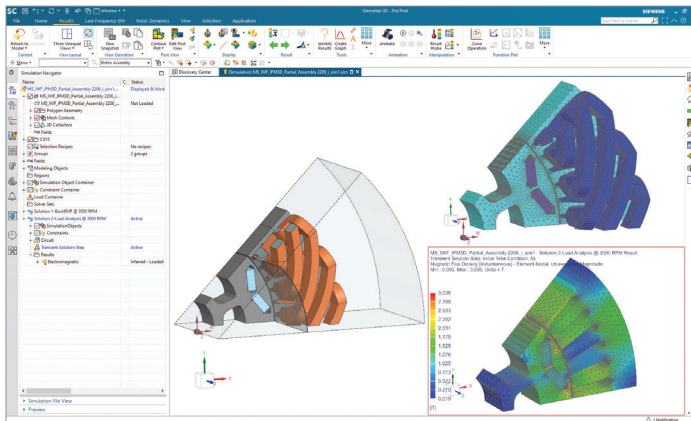

Module benefits

- Associativity between electromagnetic performance and the fully parametrized CAD model
- Highly efficient way of defining complex electromechanical devices
- Integrated world-class material database
- Supports multidiscipline scenarios from the integrated environment

Key features

- Full detailed analysis in both 2D and 3D
- Includes static, time-harmonic and transient solvers, including motion for any number of components
- Advanced material models for low frequency electromagnetics (such as hysteresis or demagnetization)
- Integrated thermal analysis
- Circuit editor for fully coupled electromagnetic-circuit simulations

Simcenter MAGNET

Electromagnetic solver

The **Simcenter MAGNET solver** is based on low frequency electromagnetic solving technology, which is built on several decades of expertise and incorporates a wide range of capabilities and technologies for maximum performance for each application. The solver includes static, time-harmonic, and transient solver capabilities with motion. It is designed for motor engineers and electromagnetic engineers who want to improve design and achieve maximal performance and efficiency in their electromechanical systems.

Module benefits

- Achieve great accuracy due to outstanding capabilities
- Fast solvers, adapted and optimized for applications
- Benefit from an extensive electromagnetic materials library

Key features

- From 2D axisymmetric and 2D translational to full 3D models
- From static to time-harmonic, and full transient
- From single component to any number of components with motion
- Sophisticated loss models including hysteresis

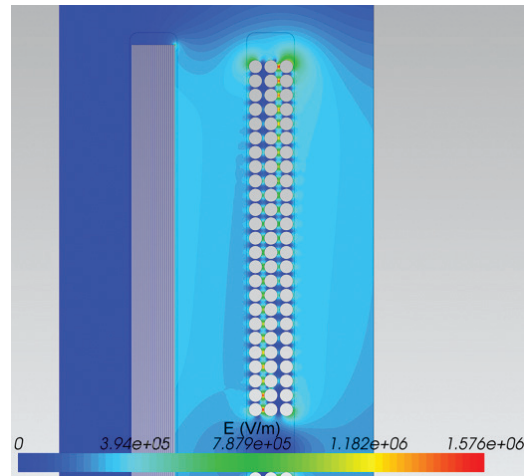
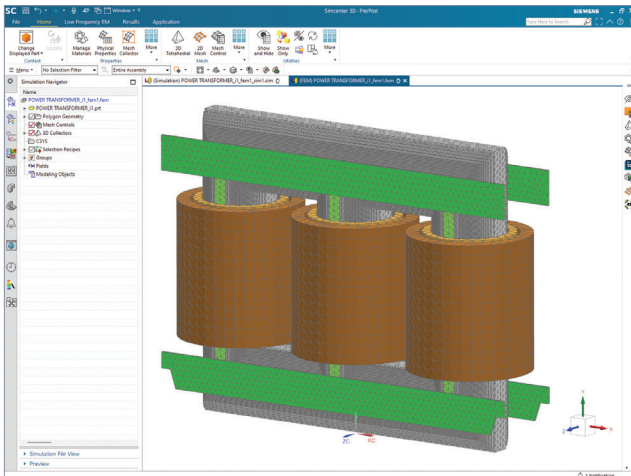

Simcenter MAGNET

Thermal solver

The thermal and electromagnetic modules of Simcenter MAGNET can be used to simulate steady-state and transient temperature distribution, considering losses in the windings as well as the core, including the eddy current and hysteresis losses.

The Simcenter MAGNET thermal solver uses Finite Elements to quickly evaluate the thermal performance of your electric device.

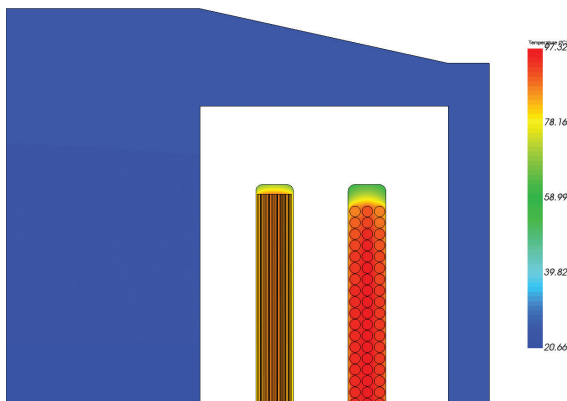

Module benefits

- Increase efficiency of electromechanical devices by considering the thermal effects
- Assess risk of demagnetization of permanent magnets and increase robustness
- Run your models in different operating conditions and easily assess effect of thermal behavior on device performance (torque, efficiency, demagnetization)

Key features

- Coupled thermal-electromagnetics co-simulation
- Steady state
- Transient

Capabilities chart

General capabilities	Specific capabilities	Simcenter 3D Low Frequency EM	Simcenter MAGNET solver	Simcenter MAGNET Thermal solver
		Low-frequency electromagnetics		
Meshing	Automatic airgap remeshing with motion		•	
	Adaption		•	•
Boundary condition	Periodic	•		
	Flux tangential	•		
	Field normal	•		
	Thin plate	•		
	Perfect electric insulator	•		
	Surface impedance (linear and nonlinear model)	•		
	Perfect Thermal Insulator	•		
	Ground	•		
	Thin resistive sheets	•		
	Specified temperature	•		
Materials	Material library for low-frequency EM (extensive set of materials)	•		
	Models for low-frequency EM materials (advanced models: hysteresis, demagnetization)	•		
	Magnet orientation	•		
Loads and excitations	Coils definition (body, face)	•		
	Coil excitation (current and voltage driven)	•		
	Circuit (strongly coupled)	•		
	Motion components (velocity and load driven, multiple degrees-of-freedom)	•		
	Electrodes	•		
Electromagnetic solver	2D axisymmetric		•	
	2D translational		•	
	3D		•	
	Static		•	
	Transient		•	
	Time Harmonic		•	
	Transient with motion		•	
	Coupled thermal - electromagnetic (steady state or transient thermal)			•

General capabilities	Specific capabilities	Simcenter 3D Low Frequency EM	Simcenter MAGNET solver	Simcenter MAGNET Thermal solver
		Low-frequency electromagnetics		
Electric Field solver	2D axisymmetric		•	
	2D translational		•	
	3D		•	
	Static		•	
	Transient		•	
	Time Harmonic		•	
	Current Flow		•	
Post-processing	Coupled thermal - electric field (steady state or transient thermal)			•
	Field results (B-field, E-field, temperature, etc.)	•		
	Quantities (voltage, current, energy, loss, force, torque, flux-linkage, temperature, heat flow, etc.)	•		
	Motion (magnetic force/torque, load force/torque, position, speed, acceleration, etc.)	•		
	Field results (E-field, Voltage, Charge density, Conductivity, Displacement currents, Permittivity, Surface charge density, temperature, etc.)	•		
Quantities (Charge, Forces and torques, Voltage, Stored electric energy)	•			

Note: Simcenter 3D Engineering Desktop is a minimum prerequisite for all Simcenter 3D products. Other dependency or prerequisites may apply for individual products.



DIGITAL INDUSTRIES SOFTWARE

Simcenter 3D for multiphysics simulation

Leveraging the use of industry-standard solvers for a full range of applications

Solution benefits

Enables users to take advantage of industry-standard solvers for a full range of applications

Makes multiphysics analysis safer, more effective and reliable

Enables product developers to comprehend the complicated behavior that affects their designs

Promotes efficiency and innovation in the product development process

Provides better products that fulfill functional requirements and provide customers with a safe and durable solution

Complex industrial problems require solutions that span a multitude of physical phenomena, which often can only be solved using simulation techniques that cross several engineering disciplines. This has significant consequences for the computer-aided engineering (CAE) engineer. In the simplest case, the physics may be weakly coupled and it is accurate and easy to chain the different physics solutions. The response results from the first solution provides data to be used as load input by a second physics solution. Because of weak coupling, the second physics does not affect the first physics.

But when there is stronger coupling between physics they cannot be treated separately and a more tightly coupled solution is required. In that case, a complex algorithmic basis with advanced coupling schemes are required to run the different physics solutions simultaneously which is often referred to as cosimulation.



Multiphysics

SIEMENS

[siemens.com/simcenter3d](https://www.siemens.com/simcenter3d)

Simcenter 3D for multiphysics simulation

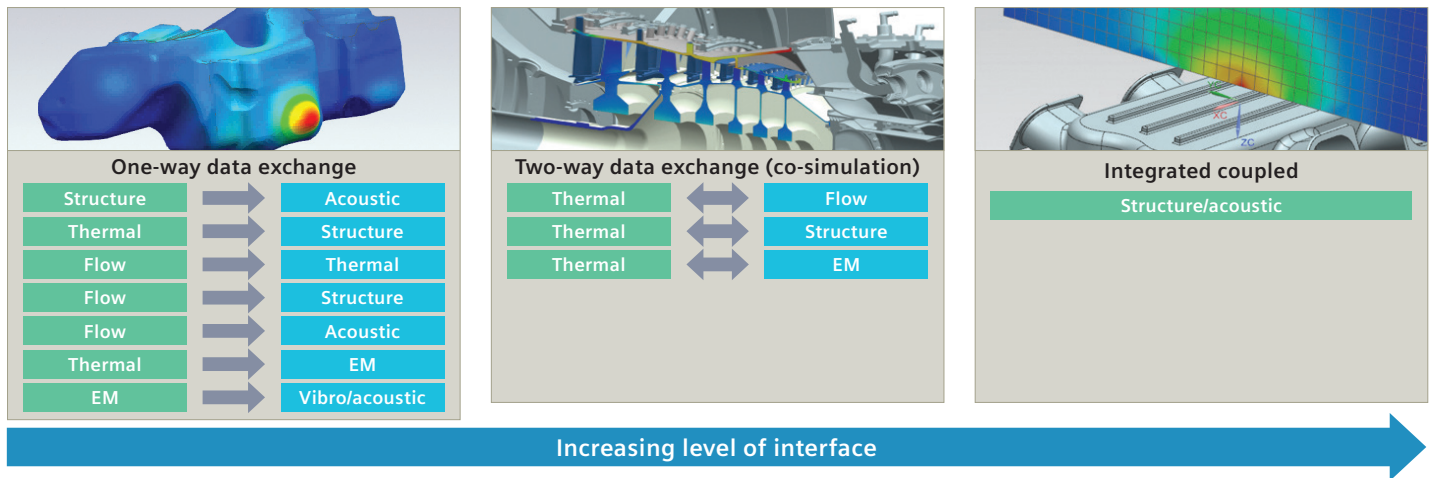

Simcenter™ 3D software streamlines multiphysics simulation through a common engineering desktop that is used for pre- and postprocessing of multiple disciplines. Through this integrated platform, you can more easily perform multiphysics simulations such as thermal-fluid, thermo-mechanical, fluid-structure interaction, vibroacoustics, aero-vibro-acoustics, electromagnetic-thermal, and electromagnetic-vibro-acoustic. Simcenter 3D also supports both weak and strong coupling depending on the physics types involved.

One integrated platform for multiphysics

Simcenter 3D combines all CAE solutions in one integrated platform and enables you to take advantage of industry-standard solvers for a full range of applications. This integration enables you to implement a streamlined multi-physical development process making multiphysics analysis safer, more effective and reliable.

This enables product developers to comprehend the complicated behavior that affects their designs. Understanding how a design will perform once in a tangible form, as well as knowledge of the strengths and weaknesses of different design variants, promotes innovation in the product development process. This results in better products that fulfill functional requirements and provide target customers with a safe and durable solution.

Enabling multiphysics analysis

Realistic simulation must consider the real-world interactions between physics domains. Simcenter 3D brings together world-class solvers in one platform, making multiphysics analysis safer, more effective and reliable. Results from one analysis can be readily cascaded to the next.

Various physics domains can be securely coupled without complex external data links. You can easily include motion-based loads in structures and conduct multibody dynamic simulation with flexible bodies and controls, vibro-acoustic analysis, thermomechanical analysis, thermal and flow analysis and others that are strongly or weakly coupled. You can let simulation drive the design by constantly optimizing multiple performance attributes simultaneously.

Quickening the pace of multiphysics analysis

With the help of Simcenter 3D Engineering Desktop, multiphysics models are developed based on common tools with full associativity between CAE and computer-aided design (CAD) data. Any existing analysis data can be easily extended to address additional physics aspects by just adapting physical properties and boundary conditions, but keeping full associativity and reusing a maximum of data.

Industry applications

Simcenter 3D multiphysics solutions can help designers from many industries achieve a better understanding of the complex behavior of their products in real-life conditions, thereby enabling them to produce better designs.

Aerospace and defense

- Airframe
 - Thermal/mechanical temperature and thermal stress for skin and frame
 - Vibro-acoustics for cabin sound pressure stemming from turbulent boundary layer loading of the fuselage
 - Flow/aero-acoustics for cabin noise occurring in climate control systems
 - Thermal/flow for temperature prediction in ventilation
 - Curing simulation for composite components to predict spring-back distortion
- Aero-engine
 - Thermal/mechanical temperature and thermal stress/distortion for compressors and turbines
 - Thermal/flow for temperature and flow pressures for engine system
 - Flow/aero-acoustic for propeller noise
 - Electromagnetic/vibro-acoustics for electric motor (EM) noise in hybrid aircraft
 - Electromagnetic/thermal for the electric motor
- Aerospace and defense
 - Satellite: Thermal/mechanical orbital temperatures and thermal distortion
 - Satellite: Vibro-acoustic virtual testing of spacecraft integrity due to high acoustic loads during launch
 - Launch vehicles: Thermal/mechanical temperature and thermal stress for rocket engines

Automotive – ground vehicles

- Body
 - Vibro-acoustics for cabin noise due to engine and road/tire excitation
 - Flow/vibro-acoustics for cabin noise due to wind loading
 - Thermal/flow for temperature prediction and heat loss in ventilation

- Powertrain/driveline
 - Vibro-acoustics for radiated noise from engines, transmissions and exhaust systems
 - Thermal/flow for temperature prediction in cooling and exhaust systems
 - Electromagnetic/vibro-acoustic for EM noise
 - Electromagnetic/thermal for the electric motor performance analysis

Marine

- Propulsion systems
 - Vibro-acoustics for radiated noise from engines, transmissions and transmission loss of exhaust systems
 - Flow/acoustics to predict acoustic radiation due to flow induced pressure loads on the propeller blades
 - Thermal/flow for temperature prediction in piping systems
 - Hull stress from wave loads
 - Electromagnetic/thermal analysis for electric propulsion systems

Consumer goods

- Packaging
 - Thermal/flow for simulating the manufacture of plastic components
 - Mold cooling analyses

Electronics

- Electronic boxes
 - Thermal/flow for component temperature prediction and system air flow in electronics assemblies and packages
 - Flow/aero-acoustics noise emitted from cooling fans due to flow-induced pressure loads on fan blades
- Printed circuit boards
 - Thermal/mechanical for stress and distortion

Making multiphysics simulation more effective and reliable

Using Simcenter 3D enables you to map results from one solution to a boundary condition in a second solution. Meshes can be dissimilar and the mapping operation can be performed using different options.

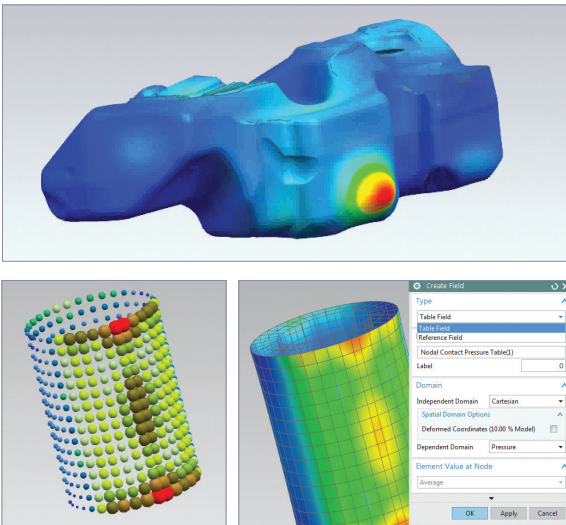

Benefits

- Make multiphysics analysis more effective and reliable by using a streamlined development process within an integrated environment

Key features

- Create fields from simulation results and use them as a boundary conditions: a table or reference field, 3D spatial at single time step or multiple time steps, scalar (for example, temperature) and vector (for example, displacement)
- Use pressure and temperature results from Simcenter 3D Thermal Multiphysics in Simcenter Nastran analysis
- Leverage displacement results from Simcenter Nastran for acoustics finite element method (FEM) and boundary element (BEM) computations
- Employ pressure and temperature results from Simcenter STAR-CCM+™ software for aero-vibroacoustics analysis
- Exploit stator forces results from electro-magnetics simulation for vibro-acoustics analysis
- Results from third-party solvers can also be used for mapping: ANSYS, ABAQUS, MSC Nastran, LS-DYNA

Coupling multiphysics simulation with flow and thermal problems

Simcenter 3D Thermal Multiphysics is a powerful and comprehensive solution for computational fluid dynamics (CFD) problems. Seamlessly combining the capabilities thermal and flow solvers, you can investigate a wide range of multiphysics scenarios involving strong coupling of fluid flow and heat transfer. This environment delivers a consistent look and feel for performing multiphysics simulations, so the user can easily build coupled solutions on the same mesh using common element types, properties and boundary conditions, as well as solver controls and options.

Benefits

- Gain insight through coupled thermo-fluid multiphysics analysis
- Achieve faster results by using a consistent environment that allows you to quickly move from design to results

Key features

- Consider complex phenomena related to conjugate heat transfer
- Thermally connect disjoint and dissimilar mesh faces and edges
- Connect dissimilar fluid meshes at interfaces between complex assemblies
- Speed up solution time with parallel calculations
- Couple 1D to 3D flow submodels to simulate complex systems
- Easily include mechanical effects with SimcenterNastrantoperformcoupledthermal-fluid-structural simulations using the same model
- Live results post-processing and solver parameters control during solve

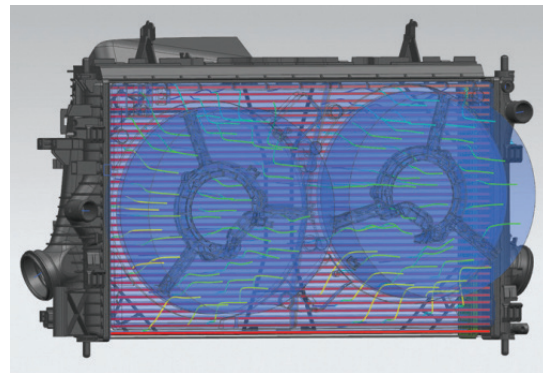
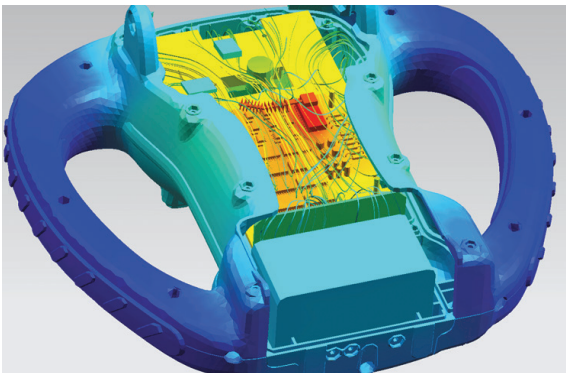

Coupling multiphysics simulation of mechanical, thermal, and flow problems

Simcenter 3D Multiphysics leverages the structural physics of Simcenter Nastran with the thermal and flow physics of Simcenter 3D Thermal Multiphysics.

Simcenter Nastran is an industry standard solver for linear, nonlinear, and dynamic structural solutions. Simcenter 3D Thermal Multiphysics is a powerful and comprehensive solution for thermal and computational fluid dynamics (CFD) problems.

With Simcenter 3D Multiphysics users have a single easy-to-use environment for setting up solutions that couple any of combination these three physics – structures, thermal, and flow. The environment delivers a consistent look and feel for performing multiphysics simulations, so the user can easily build coupled solutions on a single mesh using common element topologies, properties and boundary conditions, as well as solver controls and options.

You can build the solution by systematically considering single physics first to validate their performance, and then adding other physics to build to the desired tightly coupled cosimulation solution.

The solution has a wide range of control capabilities to consider steady-state and transient effects. With the structural solution, you can span the range of basic linear elastic solutions to fully nonlinear with contact, plasticity, and large displacement effects – all of which can be coupled with the thermal and flow effects inherent in the system.

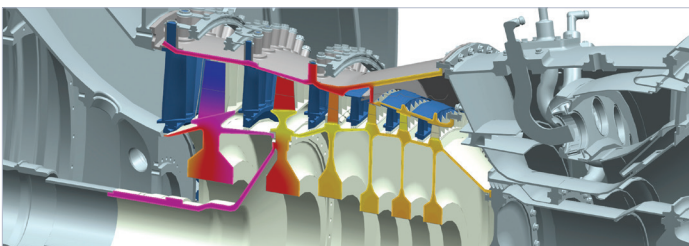
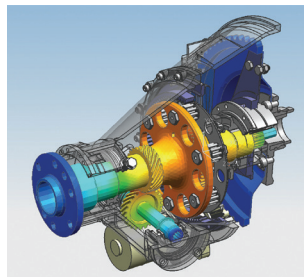

Benefits

- Extend the mechanical, thermal and flow solution capabilities in Simcenter 3D to simulate complex phenomena with a comprehensive set of modeling tools
- Reduce costly physical prototypes and product design risk with high-fidelity thermal-mechanical simulation
- Gain further insight about the physics of your products
- Leverage all the capabilities of the Simcenter 3D integrated environment to make quick design changes and provide rapid feedback on thermal performance

Key features

- Advanced simulation options for coupled thermomechanical analysis of turbomachinery and rotating systems
- Tightly-coupled thermomechanical analysis with Simcenter Nastran for axisymmetric, 2D, 3D, and mixed 2D-2D axisymmetric-3D representations
- Combines Simcenter Nastran multi-step nonlinear solution with industry-standard Simcenter 3D thermal and flow solvers
- Easily include flow effects with the integrated CFD solver inside Simcenter 3D Thermal Multiphysics to perform coupled thermal-fluid structural simulations using the same model
- Live results post-processing & solver parameters control during solve

Coupled multiphysics simulation involving dynamics and acoustics

The Simcenter Nastran software Advanced Acoustics module extends the capabilities of Simcenter Nastran for simulating exterior noise propagation from a vibrating surface using embedded automatically matched layer (AML) technology. Simcenter Nastran is part of the Simcenter portfolio of simulation tools, and is used to solve structural, dynamics and acoustics simulation problems. The Simcenter Nastran Advanced Acoustics module enables fully coupled vibro-acoustic analysis of both interior and exterior acoustic problems.

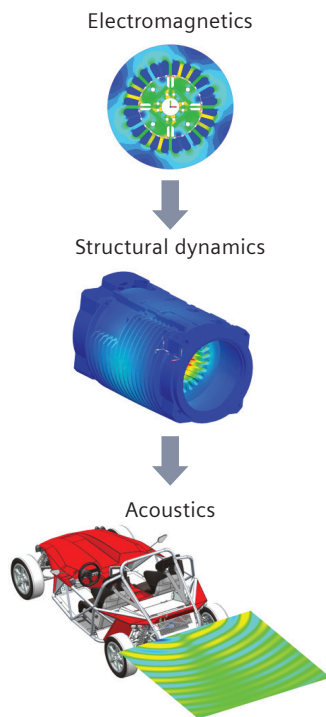

Benefits

- Easily perform both weakly and fully coupled vibroacoustic simulations
- Simulate acoustic problems faster and more efficiently with the next-generation finite element method adaptive order (FEMAO) solver

Key features

- Simulate acoustic performance for interior, exterior or mixed interior-exterior problems
- Correctly apply anechoic (perfectly absorbing, without reflection) boundary conditions
- Correctly represent loads from predecessor simulations: mechanical multibody simulation, flow-induced pressure loads on a structure and electromagnetic forces in electric machines
- Include porous (rigid and limp frames) trim materials in both acoustic and vibro-acoustic analysis
- Request results of isolated grid or microphone points at any location
- Define infinite planes to simulate acoustic radiation from vibrating structures close to reflecting ground and wall surfaces

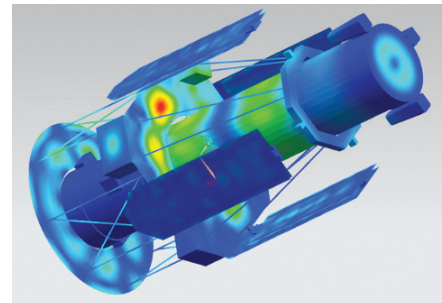
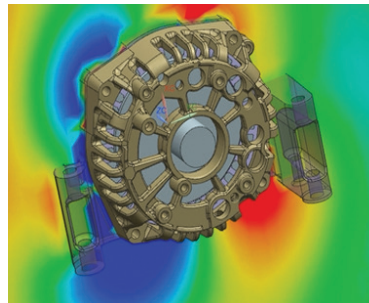
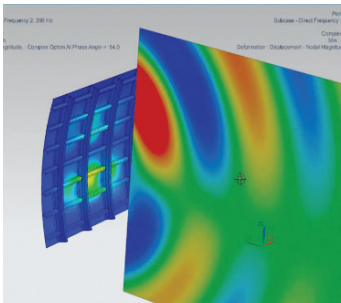

Simcenter 3D

Aero-Vibro-Acoustics

This product supports creating aero-acoustic sources close to noise-emitting turbulent flows and allows you to compute their acoustic response in the environment (exterior or interior); for example, for noise from heating ventilation and air conditioning (HVAC) or environmental control system (ECS) ducts, train boogies and pantographs, cooling fans and ship and aircraft propellers. The product also allows you to define wind loads acting on structural panels, leading to vibro-acoustic response; for instance, in a car or aircraft cabin.

Module benefits

- Derive lean, surface pressure-based aero-acoustic sources for steady or rotating surfaces
- Scalable and user-friendly load preparation for aero-vibro-acoustic wind-noise simulations
- Import binary files with load data directly into Simcenter Nastran for response computations

Key features

- Conservative mapping of pressure results from CFD to the acoustic or structural mesh
- Equivalent aero-acoustic surface dipole sources
- Equivalent aero-acoustic fan source for both tonal and broadband noise
- Wind loads, using either semi-empirical turbulent boundary layer (TBL) models or mapped pressure loads from CFD results

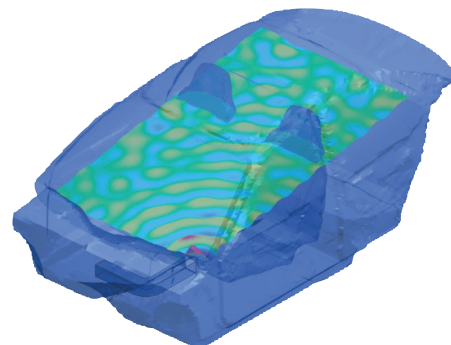
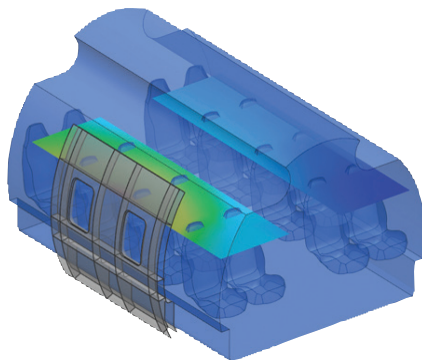
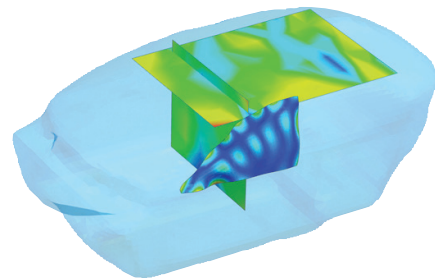
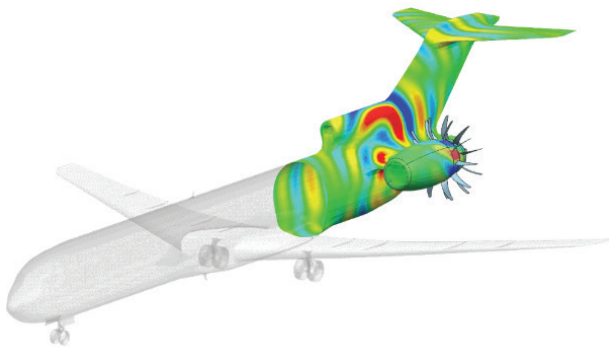

Simcenter 3D

Electromagnetics/Thermal

Simcenter MAGNET™ Thermal software can be used to accurately simulate temperature distribution due to heat rise or cooling in the electromechanical device. Simcenter 3D seamlessly couples with the Simcenter MAGNET solver to provide further analysis: You can use power loss data from Simcenter MAGNET as a heat source and determine the impact of temperature changes on the overall design and performance.

Each solver module is tailored to different design problems and is available separately for both 2D and 3D designs.

Module benefits

- Achieve higher fidelity predictions by taking temperature effects into account in electromagnetic simulations
- Leverage highly efficient coupling scenarios

Key features

- Simulates the temperature distributions caused by specified heat sources in the presence of thermally conductive materials
- Couples with Simcenter MAGNET solver for heating effects due to eddy current and hysteresis losses in the magnetic system

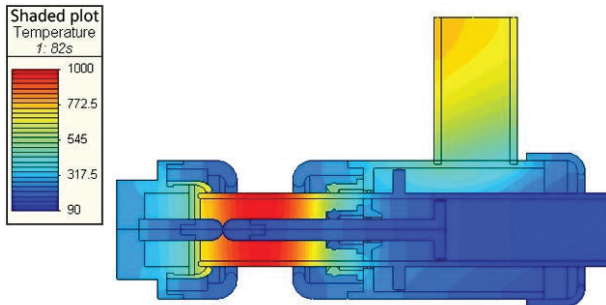

Capabilities chart

General capabilities	Types of coupling		Solvers						
	One-Way	Two-Way	Simcenter Nastran (Structures and FEM Acoustics)	Simcenter 3D Acoustics (BEM, ABEM, Ray Acoustics)	Simcenter 3D Thermal Multiphysics	Simcenter 3D Electromagnetics	Simcenter 3D Motion	Simcenter STAR-CCM+ Simcenter FLOEFD	Third-party solvers
Legend • = type of coupling supported V = vibration A = acoustics F = flow T = thermal S = structural/mechanical E = electromagnetics FX = flexible body MBD = multibody dynamics/motion C = controls									
Supported analysis types									
Vibro-acoustics (V-A)	•	•	V-A	A				V	V
Thermal-mechanical (T-S)	•	•	S		T				
Flow-thermal (F-T)	•	•			T-F			F	F
Fluid-structure interaction (F-S)	•		S		F			F	
Thermal-fluid-structure interaction	•	•	S		T-F			F	
Aero-acoustics (F-A)	•		A					F	F
Aero-vibro-acoustics (F-V-A)	•	•	V-A	A				F	F, V
Thermal-electromagnetics (T-E)	•	•				T-E			
Vibro-acoustics - electromagnetics (V-A-E)	•		V-A	A		E			E, V
Flexible multibody dynamics (FX-MBD)	•		FX				MBD		FX
Motion-control simulation (MBD-C)		•					MBD	C	C

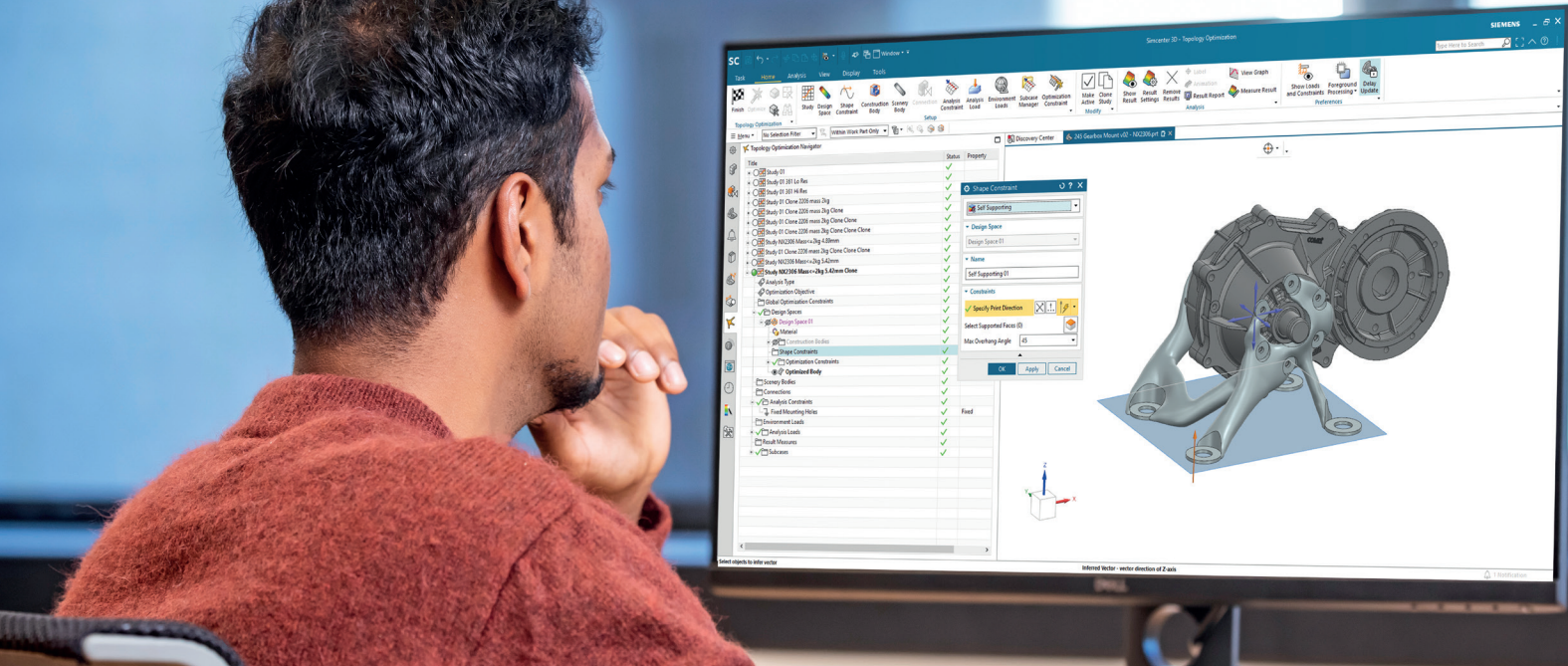

DIGITAL INDUSTRIES SOFTWARE

Simcenter 3D for generative engineering

Improving and optimizing product designs

Solution benefits

Discover a better design faster

Eliminate model simplification, model fitting or surrogates

Eliminate design overhead and achieve significant productivity gains

Reduce research time, product development costs and product design risks

Support design reviews by providing sensitivity to design variable

Simcenter™ 3D software optimization solutions relieve the burden of improving product designs by automating the iterative process. This enables you to compare your design's performance against specifications. It enables you to start at topology optimization and extend to design space exploration with more classical parametric optimization capabilities.

A platform for multidiscipline simulation

The Simcenter 3D design space explorer and optimization simulation solutions are part of a larger, integrated multidiscipline simulation environment with the Simcenter 3D Engineering Desktop at the

core for centralized pre-/postprocessing for all Simcenter 3D solutions. This integrated environment helps you to achieve faster CAE processes and perform multidisciplinary optimization processes across physics domains, such



Generative Engineering

SIEMENS

[siemens.com/simcenter3d](https://www.siemens.com/simcenter3d)

as structural simulation, thermal simulation, fluid dynamics, multibody dynamics, electromagnetics, durability, dynamics, and acoustics simulation.

Automating the product performance process

Simcenter 3D optimization solutions streamline and automate optimization processes by using sophisticated algorithms to search the entire design space and find the right combination of parameters that will yield optimal design and performance. Define your desired optimums by specifying the design and performance objectives for characteristics such as minimum weight, shape constraints and minimum stress or strain. Define parameters as tunable variables for the optimization tool, including geometric, material, loads and boundary conditions.

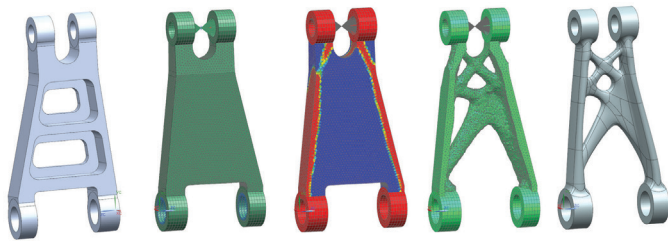

Reduce design risk and accelerate innovation

By better understanding the complex relationships among design parameters and how changes affect them, you can gather insight into product performance risk and accelerate innovation by determining feasible designs that satisfy all requirements.

Shorten time-to-market with confidence

Analyze your product performance deviations from specifications in a variety of operating conditions, and shorten time-to-market by automating thousands of simulations that would otherwise have to be performed manually.

Industry applications

The Simcenter 3D optimization solutions can help designers in virtually any industry to achieve a better understanding of the complex relationships among design parameters and how changes affect these relationships, helping them realize a better design.

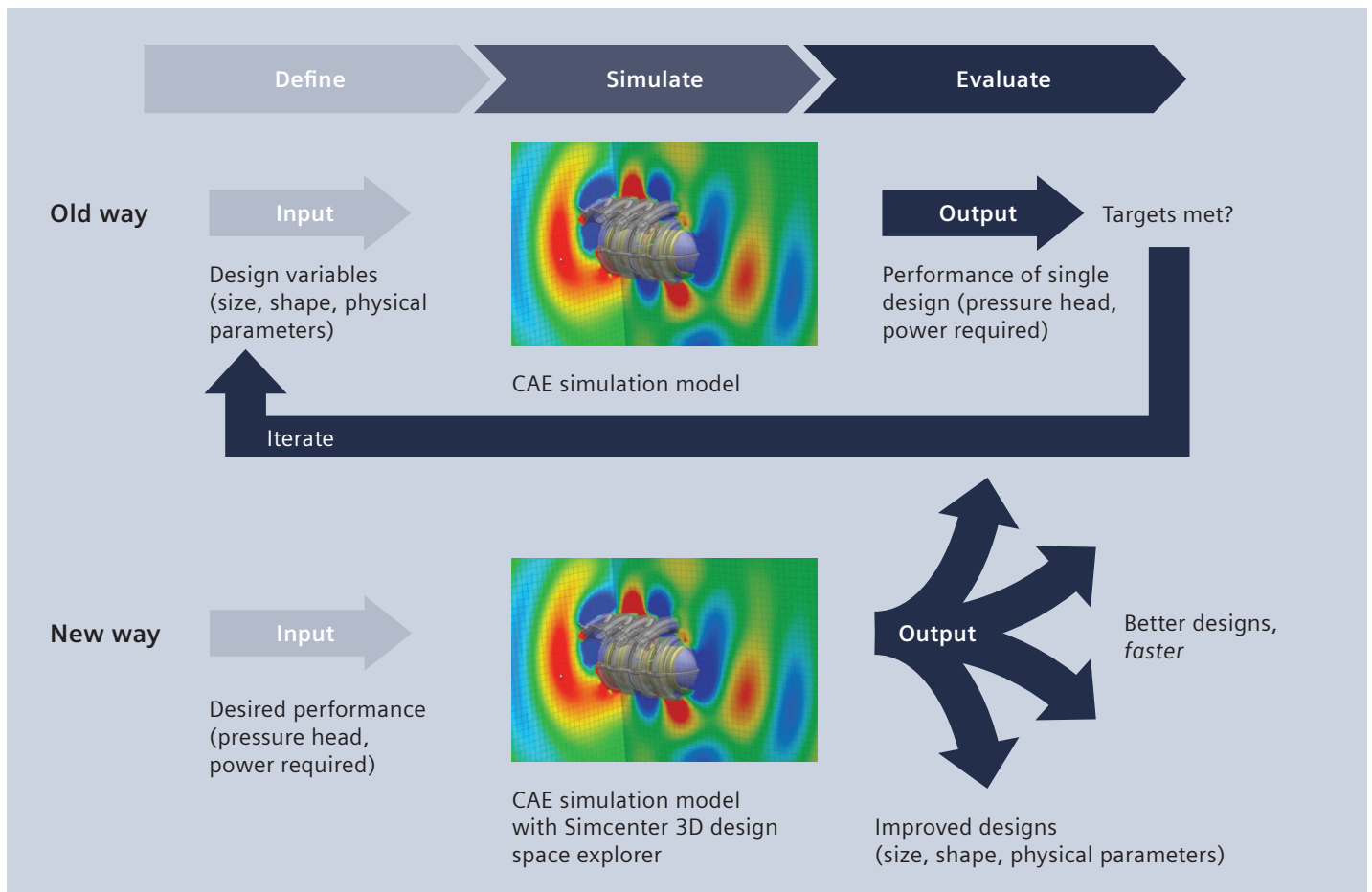

Aerospace and defense

- Airplane frame weight reduction and balancing attributes such as stiffness, modal frequencies, buckling loads
- Airplane wing weight reduction and balancing attributes such as stiffness, modal frequencies, buckling loads
- Airplane weight reduction and balancing attributes for composite airplanes (laminates/ply thicknesses)
- Satellite optimization for thermal stress and distortion, composites, modal frequency
- Launch structure weight reduction
- Aero engine fan shape optimization (compensation for centrifuge and other mechanical effects)
- Aero engine compressor weight reduction and performance balancing
- Aero engine turbine weight reduction and performance balancing
- Aero engine casing weight reduction

Automotive and transportation

- Body roof crush, panel strength, stiffness, frame durability
- Powertrain/driveline performance optimization, torque loads, thermal stress and distortion
- Chassis harshness loads, suspension deflections
- Suspension performance optimization and weight reduction
- Off-highway vehicles balancing weight reduction with strength, durability, rollover protection structure (ROPS), stability
- Manufacturing tool thermal stress and distortion, modal frequency, bolted stresses
- Support structure stability, stress

Marine

- Full ship stiffness, deformation, strength optimization, weight reduction

Consumer goods

- Packaging shape optimization

Simcenter Nastran Optimization

Simcenter Nastran® Optimization software enables customers to establish design sensitivity based on simulated performance conditions and then synthesize and optimize designs. Efficient algorithms permit the use of hundreds of design variables and responses for the largest models. A broad range of robust optimization algorithms and approximation methods provide the backbone of a solution that allows numerous design variables and constraints to be more easily linked and rationalized to identify critical issues.

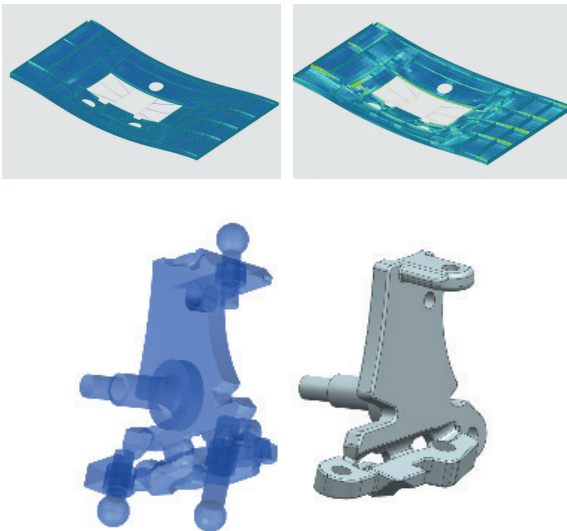

Module benefits

- Reduce design risk by better understanding the complex relationships among design parameters and how changes affect these relationships
- Improve confidence that your product will perform to specifications under a variety of operating conditions and manufacturing tolerances
- Accelerate innovation by determining feasible new designs that satisfy all requirements
- Shorten time-to-market by automating thousands of simulations that would otherwise have to be performed manually

Key features

- Optimization of Simcenter Nastran models
- Constraints related to static, normal modes and buckling analysis
- Optimization capabilities associated with Simcenter Nastran Enterprise Advanced analysis types, such as superelements, dynamic response, modal frequency response, direct frequency response, modal transient response, acoustic analysis, static aeroelasticity and flutter
- Large scale optimization problems thanks to robust optimization algorithms and sparse matrix solutions
- There are hundreds of responses available for the objective and constraints
- Synthetic variables and responses can be created and combined with other responses to meet objectives within defined constraints

Simcenter Nastran Topology Optimization

Simcenter Nastran Topology Optimization software offers the capability to optimize many different criteria in support of generative engineering. The solution enables the user to optimize the topology of regions defined as solids or shells and offers the capability to predict solid and lattice zones.

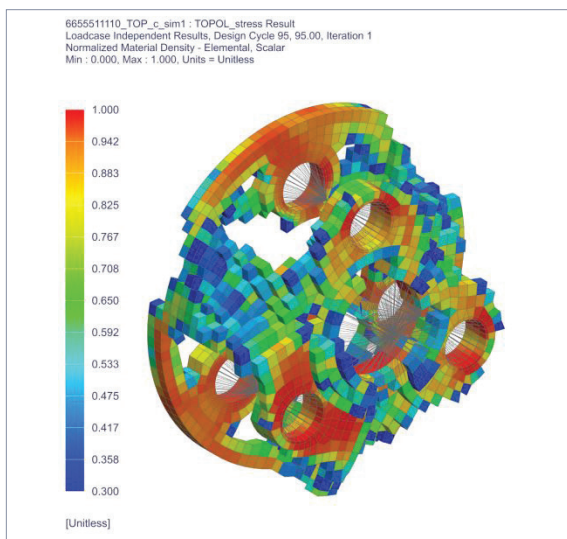
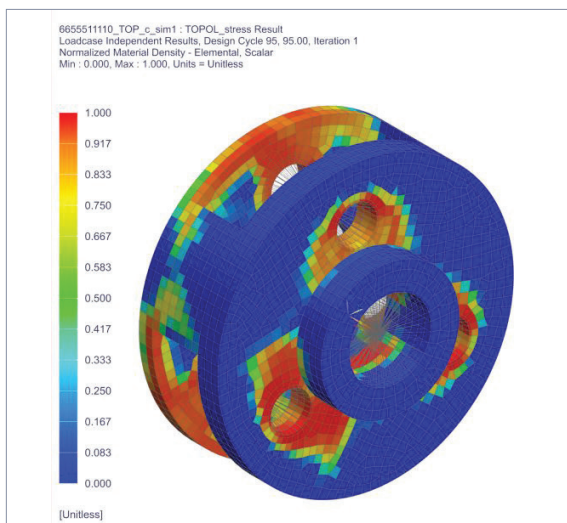

Module benefits

- Shorten time-to-market by directly starting from optimal topology for a large set of

optimization objectives and constraints related to statics, modal, buckling, direct and model frequency analysis. Examples include maximising or minimizing stiffness, mass and mode, or constraining mass, displacement, or stress etc.

- Full integration in Simcenter 3D means there is no need to export files, and only one UI is used for the entire workflow
- Functional requirements are represented by shape control constraints, for example to support manufacturing, symmetry and size requirements
- Solid and lattice zone prediction

Key features

- Many methods are available to build the finite element (FE) model: orphan mesh, computer-aided design (CAD) part and finite element method (FEM), CAD assembly and FEM or AFEM
- The design areas can be constructed using 2D shell or 3D solid elements and there can be multiple design areas with different materials representing different parts in an assembly, or homogenized meta-materials (lattices, varying density printed materials, etc.)
- Within a single topology optimization, the user can have any mix of analysis subcases selected from linear statics, normal modes, buckling analysis, as well as direct and modal frequency
- There are hundreds of responses available for the objective and constraints
- Synthetic variables and responses can be created and combined with other responses to meet objectives within defined constraints

Simcenter 3D

Design Space explorer

Simcenter 3D Design Space explorer is fully integrated into Simcenter 3D Desktop. It provides users with the power of parametric design space exploration at a low adoption cost. It helps companies to move beyond the standard use of simulation for validation, troubleshooting and basic prediction by automatically exploring broader design spaces to discover much better designs rapidly.

The user can leverage smooth process integration, which simplifies the virtual prototype build process and accelerates virtual prototype testing. This enables the user to access efficient design search capabilities without the need to simplify models. Additionally, the user has access to an insight and discovery interface that is a central part of virtual product development rather than an afterthought.

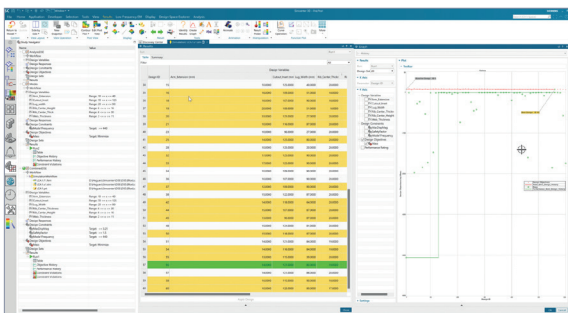
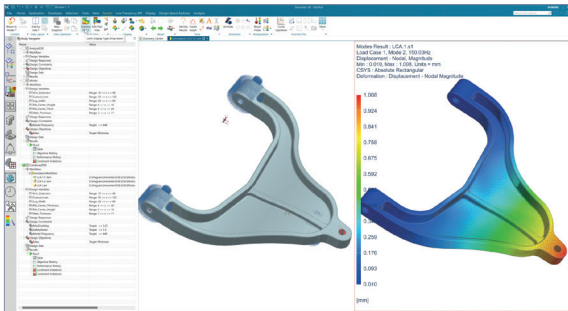

Module benefits

- Efficiently find good designs with many variables
- Selecting algorithms are automated with an A.I. assisted selection strategy continuously updating throughout the design study
- The solution leverages all search strategies simultaneously
- Eliminates iteration and finds the best way to traverse the design space every time
- With an advanced algorithm and easy-to-use interface, the solution precludes the need for optimization expertise

Key features

- Design space exploration and optimization for Simcenter 3D models
- Extensive support for Simcenter 3D model parameterization (including geometry, materials, finite element characteristics, solution parameters, etc.)
- Automates workflows, which streamlines data transfer across tools, eliminates errors in the process and significantly increases the efficiency
- Plethora of design-of-experiment (DoE) algorithms
- Cutting edge SHERPA optimization strategy, the advanced auto-tuning optimization strategy for single and multi-objective optimization
- Support for mixed continuous/discrete variable problems with multiple constraints
- A powerful but easy-to-use data analytics solution for gaining valuable insights into designs and design space
- Support for surrogate model creation and export

Simcenter 3D

Geometry Optimization

Simcenter 3D contains geometric and sizing optimization capabilities, all part of the standard Simcenter 3D Engineering Desktop. It provides classical capabilities for the selection of design variables as well as objective and constraint functions together with several optimization solution controls and postprocessing capabilities.

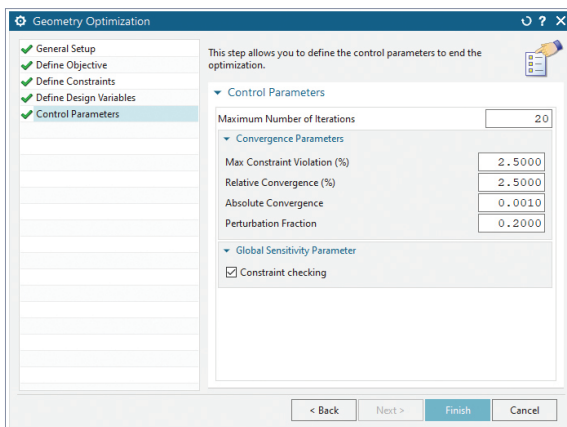
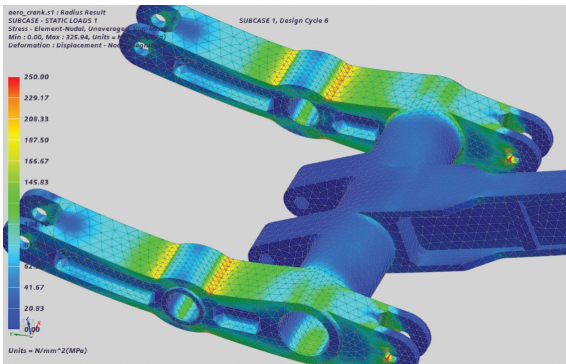

Module benefits

- Easily optimize geometry of element properties of Simcenter 3D models and the associated CAD models
- Reduce design risk by better understanding the complex relationships among design parameters
- Improve confidence that your product will perform to specifications under a variety of operating conditions and manufacturing tolerances

Key features

- Optimization of Simcenter 3D models and the associated CAD models
- Mixed CAD and FE geometry optimization: FE beam section properties, FE shell thickness, CAD model feature dimensions, CAD model sketch dimensions, expressions, including expressions that define an FE load
- Supported solvers: Simcenter Nastran, Simcenter 3D Thermal, Simcenter 3D Flow, Simcenter ESC, Simcenter SST, MSC Nastran, ANSYS, ABAQUS
- Types of responses for objective and constraints will vary depending on the solver. Examples include: weight, volume, temperature, mass flow, Joule data, radiation view factors, etc.
- FE result measures can also be used as responses; for example, max displacement, average Von Mises Stress. These can be measured globally or locally based on geometry distribution; for instance, on a face or along an edge
- Optimization solution data can be displayed in a spreadsheet

Capabilities chart

General capabilities	Specific capabilities	Simcenter Nastran Optimization	Simcenter Nastran Topology Optimization	Simcenter 3D Design Space explorer
Integration with Simcenter 3D		•	•	•
Model parameterization	With associated CAD models	•	•	•
	Without associated CAD models	•	•	•
	Full Simcenter Nastran elements types suitable for analysis types	•	•	•
	Full Simcenter Nastran load and constraint types suitable for a nalysis types	•	•	•
	Other solver environments			•
Design volume	2D, 3D elements		•	
	Multiple design volumes		•	
	Different materials to present different parts and meta-materials (lattices, varying density printed materials, etc.)		•	
Variables	Every FE element in the design volume(s)		•	
	Element physical properties	•		•
	Composite element properties	•		•
	Connecting element properties	•		•
	Material properties	•		•
	CAD model expressions include feature and sketch dimensions, load inputs			•
Derived variables and formulas based on model responses			•	
Materials	Isotropic, anisotropic, orthotropic	•	•	•
Analysis types	Linear statics	•	•	•
	Structural dynamics	•	•	•
	Buckling	•	•	•
	Acoustics			•
	Thermal			•
	Flow			•
	Coupled thermal/flow			•
Nonlinear			•	
Optimization objective	Single objective	•	•	•
	Single global or subcase objective	•	•	•
	Multi-objective			•
Optimization constraints	Multiple	•	•	•
	Multiple global or subcase objectives	•	•	•
	Relationships between variables			•
	Shape control constraints		•	
Optimization algorithms	Gradient	•	•	•
	Penalty laws linear, solid isotropic material with penalization (SIMP), rational approximation of material properties (RAMP)		•	
	Lattice prediction based on lattice type characterization		•	
	Optimization controls and convergence parameters	•	•	•
	Design space exploration (DoEs, design sets)			•
	Auto-tuning optimization strategy - SHERPA			•
	Multi-objective auto tuning optimization strategy - multiobjective SHERPA			•

General capabilities	Specific capabilities	Simcenter Nastran Optimization	Simcenter Nastran Topology Optimization	Simcenter 3D Design Space explorer
Simulation automation	Sequential simulation execution	•	•	•
Postprocessing	Optimization spreadsheet to summarize objective and constraint values per iteration	•	•	•
	Simcenter 3D postprocessing functionality	•	•	•
	Dedicated normalized material density display		•	
	Auto creation of post optimization verification model		•	
	Objective and performance history			•
	Response surface modeling			•
	Correlation plots			•
	Pareto plots			•
	Principal component analysis and influence analysis			•
Analysis monitoring and control			•	
Design geometry recovery	Update of CAD models			•
	Update of FE model	•		•
	Export of smoothed mesh back to CAD for design guidance in remodeling		•	

Legend:

- = included in module
- + = additional product required

Note: Simcenter 3D Engineering Desktop is a minimum prerequisite for all Simcenter 3D products. Other dependency or prerequisites may apply for individual products.

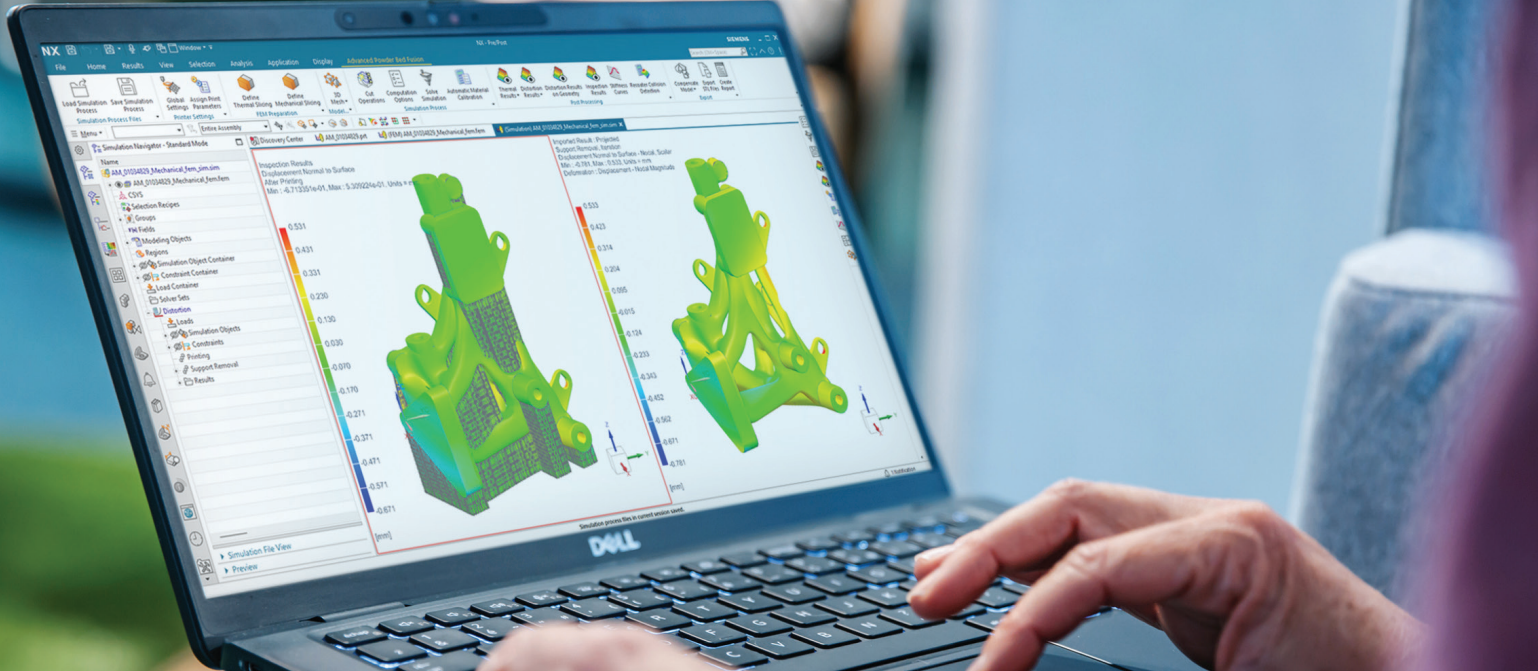

DIGITAL INDUSTRIES SOFTWARE

Simcenter 3D for additive manufacturing simulation

Print it right the first time

Solution benefits

Print right the first time

Simulate the build process for metal powder bed fusion additive manufacturing applications

Predict potential geometry distortions during the build

Efficiently investigate different build positions and support scenarios

Use either voxel- or exact tetrahedron-based meshes for your simulation

Generate compensated geometry (STL or BREP) based on the simulated distortion fields

Additive manufacturing (AM) is changing the way products are made. New machines and processes are rapidly pushing AM from the prototype environment onto the production floor. The additive manufacturing capabilities in Simcenter™ 3D software are used to predict distortions and defects before parts are printed, thereby reducing the number of test prints and improving the quality of the final print. Simcenter is part of the Siemens Xcelerator business platform of software, hardware and services.

High-quality simulation environment

The high-quality simulation capabilities of Simcenter 3D are paramount to industrializing AM. It gives you the option to use either voxel or tetrahedron elements for meshing. The tetrahedral mesh allows you to accurately model thin features, while the voxel mesh is very robust, easy to use and generates rapidly.

Enhanced inherent strain approach

Powder bed fusion printing is a layer-by-layer welding process that leads to layer shrinkage during printing and cool down. This shrinkage is modeled using an inherent strain that is calculated via calibration print. To improve the inherent strain simulation, Simcenter 3D AM allows you to combine it with a thermal simulation.

SIEMENS

[siemens.com/simcenter3d](https://www.siemens.com/simcenter3d)

Simcenter 3D for additive manufacturing simulation

Print it right the first time

Calculated distortions can be used to compensate the part prior to the printing process. The initial geometry can be automatically morphed into the compensated shape and replaced in the built tray for further analysis, or it can be sent directly to the printer to be printed correctly the first time.

Fully integrated with NX end-to-end workflow

Simcenter 3D for AM is seamlessly integrated into the end-to-end Siemens digital enterprise software AM workflow. The process is streamlined to simplify the process for non-expert computer-aided engineering (CAE) users, who's work can be continued in an expert's workflow if required.

Providing a platform for multidiscipline simulation

The Simcenter 3D AM solution is part of a larger, integrated multidiscipline simulation environment with Simcenter 3D

Engineering Desktop at the core for centralized pre-/postprocessing for all Simcenter 3D solutions. This integrated environment helps you to achieve faster CAE processes and streamline multidisciplinary simulations that integrate additive manufacturing with any of the Simcenter 3D solutions, such as thermal mechanical, vibro-acoustic or other more complex analyses.

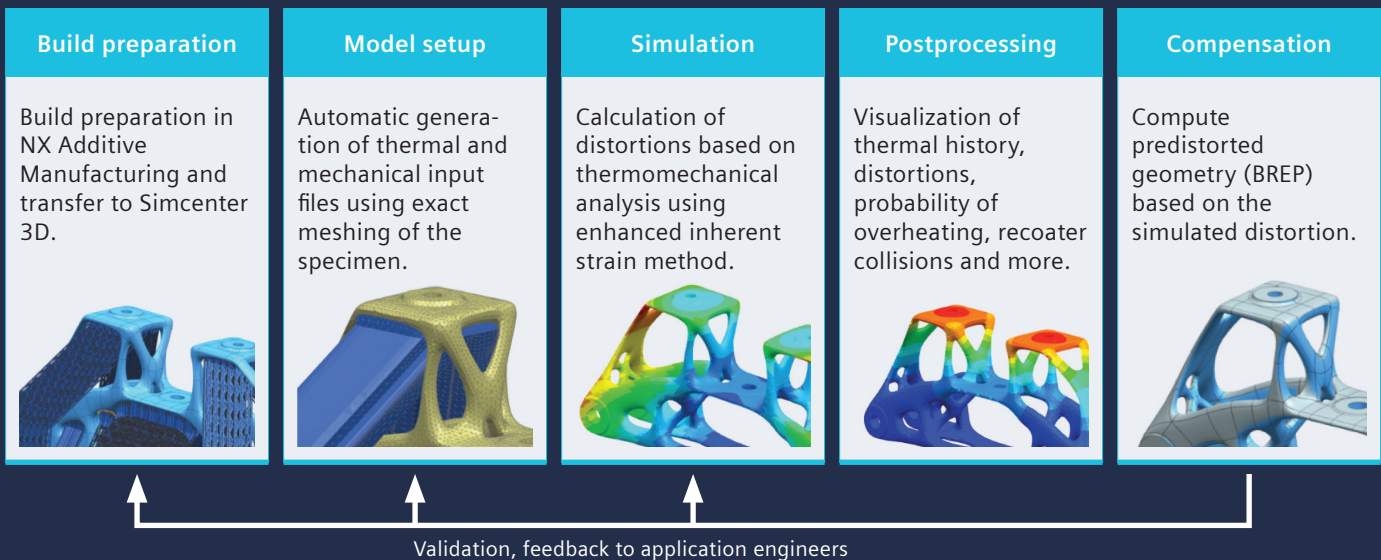
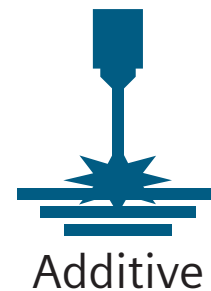

Industry applications

Today, AM is still mainly a research and development (R&D) activity as this process remains expensive and slow, preventing its use for large projects such as in the automotive industry. However, some industrial applications are already linked to the printing of complex parts, which are difficult to produce by traditional methods. The primary goal is to create parts that are lightweight and have good mechanical properties. Repairing parts previously produced by traditional processes can also be a valuable application of AM due to the unique nature of each component.

Aerospace and defense

The space industry already produces structural parts for launchers. The goal is to produce parts that are lightweight and have good mechanical properties.

The airplane industry is also developing this technology, but is in more of an exploratory phase with the goal of producing components with complex geometry.

Industrial machinery

Power generation appears to be an industry that is exploring AM to produce turbine blades and other combustion chamber components. AM can also be applied to repairing existing turbines.

Automotive industry

Lightweight structures for racing cars and completely new bionic designs can be manufactured with additive manufacturing technology. Generative design can be used to find new proposals that can be manufactured with additive manufacturing technology.

NX AM integrated solution

Simcenter 3D

**Simulate printing process
Predict thermal distortion
Allow compensation and
print it right the first time**

Simcenter 3D

Additive Manufacturing

Simcenter 3D Additive Manufacturing simulates the AM process for selective laser melting (SLM). The setup from a part in the built tray, including support structures, is used as a basis. The user selects the parts to simulate and define printing process parameters (material, number of parts, layer slicing, laser parameters, etc.) and run the simulation. The result is the temperature distribution and distortion of the part.

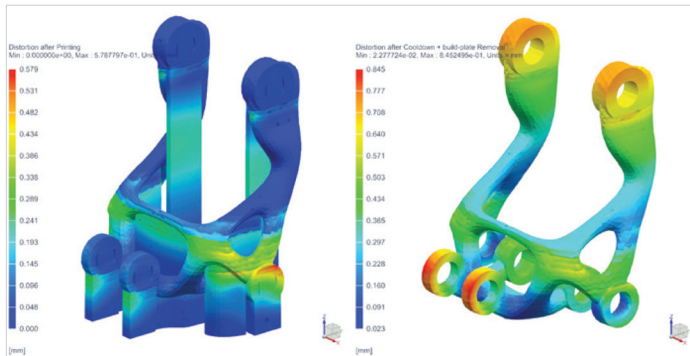

Module benefits

- Simulation of the build process for powder bed fusion metal prints
- Fully integrated into the NX™ software additive manufacturing framework, which is also part of the Siemens Xcelerator
- Unique model setup and solving methodology

Key features

- Couple inherent strain method with thermal simulation for improved accuracy
- Consideration of support structures from fixed plane modules
- Analyze thermal distribution
- Analyze distortion before and after support removal
- Analyze the effect of a flexible build plate, stress relief and the order of support removal on the distortion of the part
- Visualize distortion results on geometry
- Detect recoater collision
- Use distortion results to compute and export compensated geometry
- Export high quality distorted STL files
- Automatic report creation

Pre-deformation in Simcenter 3D

Simcenter 3D Additive Manufacturing is used to compute the distortion of parts during the AM process. The part distortions can be transferred to the initial geometry to compensate for them. The compensated geometry can be exported as facet-based STL model, or as a fully parametric boundary representation (BREP) model via the Omnimesh Add-on. The compensated part file can be used to replace the original part on the build tray and can then directly be sent to the printer or used for validation.

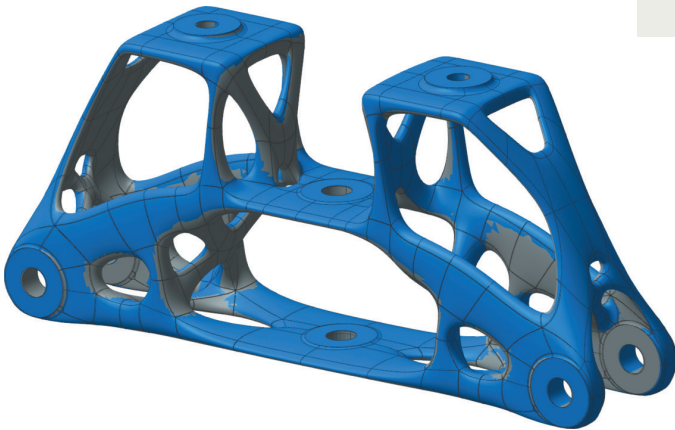

Omnimesh benefits

- Compensation of BREP geometry
- Generation of NX part files of compensated geometry

Key features

- Morph the parametric part for compensation
- Read distortion field from Simcenter 3D Additive Manufacturing
- Fully integrated into the additive manufacturing workflow

Capabilities chart

General capabilities	Specific capabilities	Simcenter 3D Additive Manufacturing	OmniMesh for Simcenter 3D
Simulation capability			
Distortion analysis	Layer-by-layer simulation	•	
Thermal history	Simulate the thermal history of single or multiple parts on the build tray	•	
Support failure	Prediction of support failure	•	
Recoater collision	Identify layers with large deformation in z-direction	•	
Prediction of shrinklines	Stiffness analysis of the part to identify shrinklines	•	
Thermomechanical analysis	Coupled thermomechanical analysis	•	
Heat treatment	Stress relief load case for nickel-based alloys	•	
Cool down	Cool down to ambient temperature	•	
Flexible support removal	User defined order of cuts that can be mixed with the stress relief step	•	
Support removal	One step support removal and cutoff from the build tray	•	
Flexible build plate	Model a flexible build plate with contact between the build plate and the printer	•	
Material			
Metal	Application for metal powder bed fusion	•	

General capabilities	Specific capabilities	Simcenter 3D Additive Manufacturing	OmniMesh for Simcenter 3D
Model setup			
Powder mesh	Meshing the powder for thermal analysis	•	
Detailed meshing (tetrahedrons)	Detailed meshing of the specimen	•	
Rapid meshing (voxel)	Rapid and extremely stable meshing of the specimen	•	
Mesh slicing	Layer setup is realized by mesh slicing	•	
Manual change of meshing setup	Flexibility to manually modify the mesh and simulation setup	•	
Homogenized material for support structures (tetrahedrons)	Use solid meshes for supports and apply homogenized material (properties can be determined in the application)	•	
Volume fraction based materials (voxel)	The voxel mesher will automatically calculate the support properties based on the volume fraction of solid material in the voxel elements	•	
Compensation			
Compensate geometry based on BREP body	Compensation of part in the additive manufacturing build tray		•
Compensate geometry based on STL body	Compensation of part in the additive manufacturing build tray	•	

Note: One fixed plane product is a minimum prerequisite for Simcenter 3D AM. The Simcenter 3D AM product is a prerequisite for Omnimesh for Simcenter 3D. Other dependencies or prerequisites may apply for individual products.

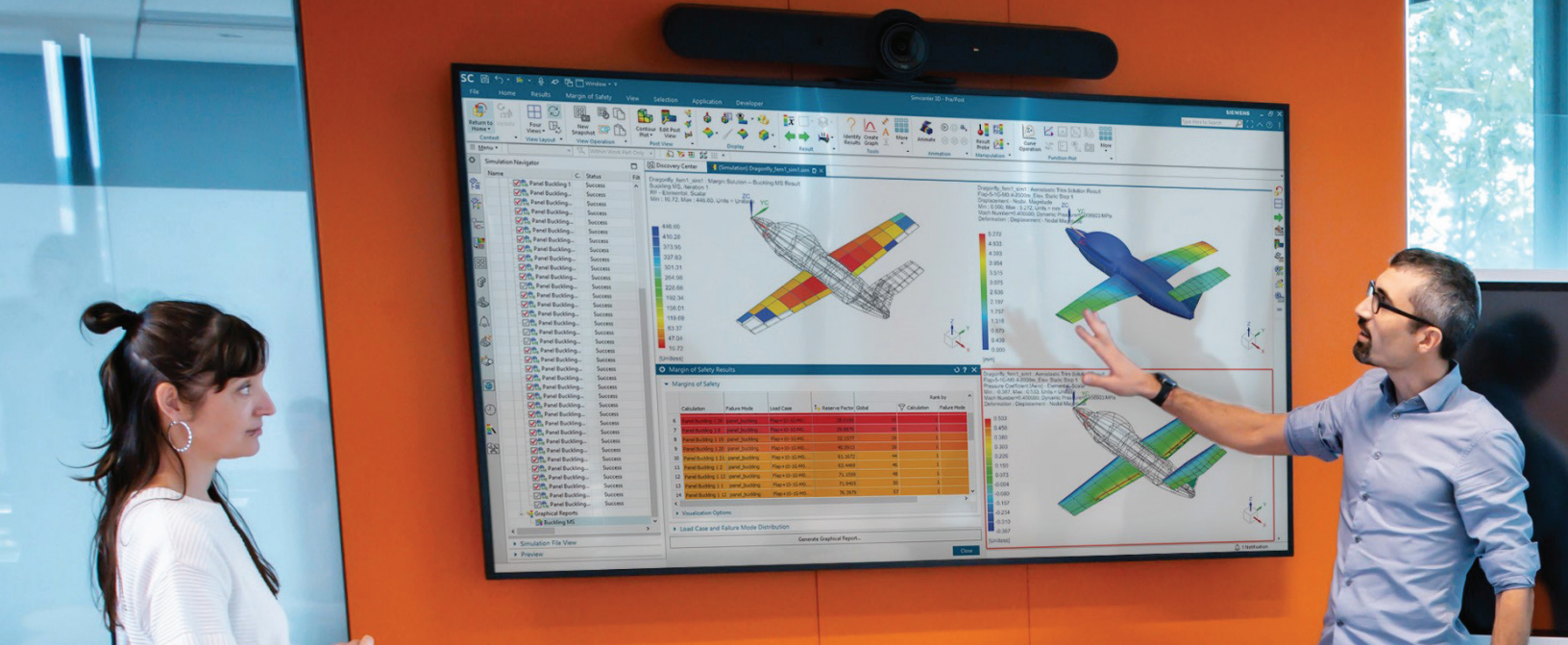

DIGITAL INDUSTRIES SOFTWARE

Simcenter 3D for aerostructures

Streamlining the structural sizing and assessment process from end-to-end

Solution benefits

Perform end-to-end aerostructure assessment in a fully integrated environment

Integrated aeroelasticity environment linked with CAD and Simcenter Nastran to perform flutter, divergence, and trim analyses

Eliminate mistakes and ramp up productivity with ready-to-use failure prediction methods from reference handbooks

Accelerate mission loads generation

Efficiently extract the most critical load cases that impact structural integrity

Customize the solution by integrating your knowhow and tools intuitively and taking advantage of your aerostructure experience

Evaluate results with dedicated criticality-focused postprocessing

Streamline report generation

The Simcenter 3D software for aerostructures solution can help you meet shorter timelines and reduce structural analysis costs with the ability to perform end-to-end aerostructure assessment in a fully integrated environment. Eliminate mistakes and ramp up productivity with ready-to-use failure prediction methods and customize your solution by integrating your internal tools and IP to streamline your aerostructures analysis processes.

Global trend in Airframe

Due to the growing number of new and emerging airframe manufacturers, there is more pressure to deliver with shorter lead times and at competitive costs. However, meeting shorter project timeline is a challenge because aircraft engineering teams today use disconnected systems for load generation and management, design, simulation,

margin of safety, and flutter analysis.

Additionally, 60 percent of the nonrecurring cost of a commercial aircraft is spent on the structure, which means that any improvement in the structural analysis process will have a key impact on reducing the delays and the cost overruns.

The powerful geometry editing and meshing capabilities of Simcenter 3D Engineering Desktop are ideal for pre- and postprocessing structural and aerodynamic models. Using Siemens Digital Industries Software's Simcenter 3D, which is part of the Simcenter portfolio, simplifies the modeling process by integrating highend finite element method (FEM) tools with geometry capabilities that assist the user in developing analysis models faster than with traditional computer-aided engineering

SIEMENS

[siemens.com/simcenter3d](https://www.siemens.com/simcenter3d)

Simcenter 3D for aerostructures

(CAE) preprocessors. This single environment provides all the necessary means to create and manage an aero-dynamic model, link it with the structural model, filter critical load cases among thousands in one go, and define aero-elasticity analysis. Simcenter 3D Margin of Safety enables structural assessment with standard analytical methods and/or your company's methods.

One-stop Structural and Aeroelastic analyses

Flying vessels require more than the typical structural analysis. Aeroelasticity can combine elastic, inertial, and aerodynamic forces at the same time. The seamless integration in Simcenter 3D Engineering Desktop of the dedicated features for pre- and postprocessing provide a unique, parametrical, and consistent environment to perform such analysis, bringing all advantages of this [fully-integrated solution](#), such as:

- CAD-Analysis associativity
- A managed environment through close integration with Teamcenter

Seamless integration for Aeroelastic models and analyses

Based on Simcenter Nastran Aeroelastic analyses, available from the Simcenter Nastran Advanced Structural Dynamics bundle, Simcenter 3D provides all the means to:

- Create aerodynamic models, based on lifting surfaces and slender bodies
- Connect structural and aerodynamic meshes thanks to dedicated "splines" to transfer loads between both models
- Define analyses parameters consistently with the structural analysis definition, with the possibility to rely on the

International Standard Atmosphere (ISA) model to ease conversions between velocities, mach numbers, altitudes, and density ratios.

The following analyses (based on Simcenter Nastran SOL144, SOL145, and SOL146) can all be modeled from within Simcenter 3D:

- Flutter (including K, KE, PK, and PKNL methods)
- Static divergence
- Trim analysis
- Control effectiveness
- Static loads evaluation
- Atmospheric Gust
- Wake
- Dynamic maneuver

Integrated aeroelastic postprocessing

Simcenter 3D not only provides a means to display results on the aerodynamic model (such as modal shapes for flutter or forces for static analysis), but it can also display global results within the same environment. Frequency vs. velocity and damping vs. velocity diagrams are directly displayable to speed up the analysis of flutter-critical speeds throughout the flight envelope. Trim analysis post-processing also comes with fully integrated global results to assess the effectiveness of control surfaces.

Filter critical load cases

Aircraft structural design can involve hundreds of thousands of load cases, but only a subset of these are critical to structural design. How do you determine which ones are important for analysis?

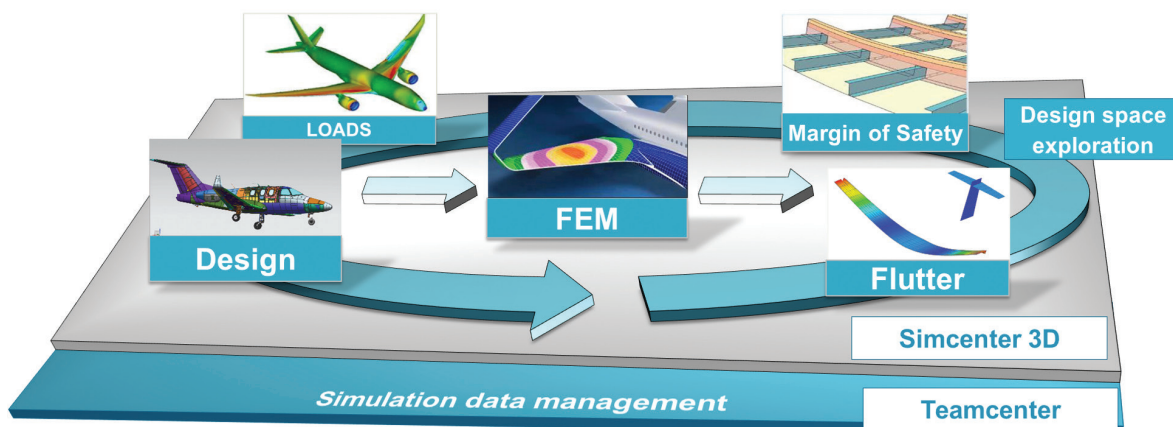

Simcenter 3D provides out-of-the-box load case enveloping capabilities that can help you quickly find the most critical loads, among thousands, for a component or an entire assembly.

Efficiently analyze margin of safety

In addition to the detailed finite element models approach, engineers can size aerostructure components using a library of analytical engineering methods. With the capability to generate stress reports using data and simulation results, engineers benefit from a consistent and integrated global process, resulting in time savings over the full design cycle.

With an increasing amount of data and results to be handled and shared between teams, models, simulation results and tools can be managed and traced in Teamcenter® software.

Integrated solution to predict margin of safety

The integrated environment also helps you perform an end-to-end process to predict margin of safety for aerostructures through dedicated pre- and post- capabilities such as:

- Streamline FE results processing throughput for terabytes of results files
- Preprocessing to prepare margin-of-safety calculations for numerous load cases
- Postprocessing that focuses on the criticality of results expressed as Margins of Safety or Reserve Factors
- 3D display of margin values combined with the typical finite element (FE) postprocessing display to graphically locate the areas that need design updates

Simcenter 3D Margin of Safety software comes with standard engineering formulas from aerostructure reference handbooks, such as E.F. Bruhn's, "Analysis and Design of Flight Vehicle Structures," M.C.Y. Niu's, "Airframe Stress Analysis and Sizing," National Advisory Committee for Aeronautics (NACA) technical

notes, NASA technical memorandums, etc. Each method comes with detailed engineering documentation.

Flexibility to embed user-defined methods

Simcenter 3D Margin of Safety and load case filtering allow you to integrate in-house libraries of methods. The availability of analysis building blocks (for example, ready-to-use engineering formulas, such as buckling and plasticity curves and out-of-the-box standard methods) enables users to save a large amount of time on integrating methods.

Customized reporting

A detailed stress report can be generated in Microsoft Word format from the Simcenter 3D Margin of Safety result and the associated finite element analysis (FEA).

The template is composed of key words, and thus can be tailored to fit company best practices. The template can include user textual feedback, snapshots, summary tables, etc.

Industry applications

Simcenter 3D Aerostructure facilitates full traceability for certification of an end-to-end integrated solution for sizing. It streamlines the structural process from computer-aided design (CAD), FE simulation and margin-of-safety calculations to reporting. Simcenter 3D Aerostructure offers a scalable solution for embedding in-house margin-of-safety methods as libraries.

CAD/CAE associativity helps you efficiently manage design changes. And a seamless connection with Teamcenter® software helps you manage the increasing amount of data and results you need to share between teams, models, simulation results and other simulation tools.

Aerospace and defense

Specific vertical application dedicated to the sizing of frames, wings and the global view of airplanes.

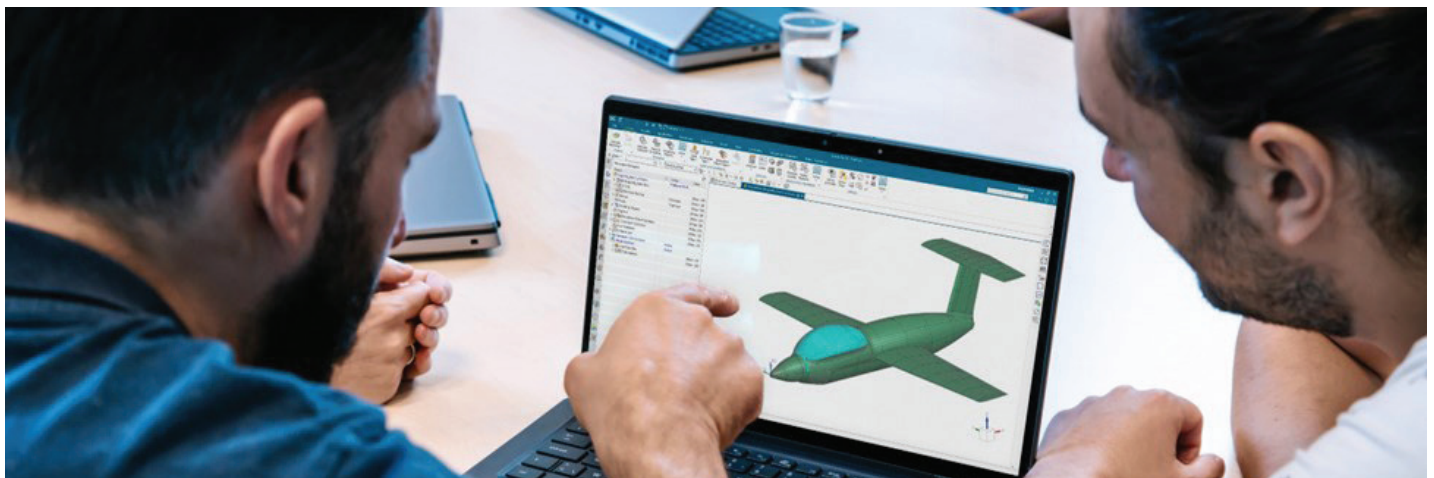

Simcenter 3D

Margin of Safety

Simcenter 3D Margin of Safety brings a streamlined, traceable and enterprise-wide approach to aerostructure sizing so you can calculate everything from static loads to [margins of safety](#).

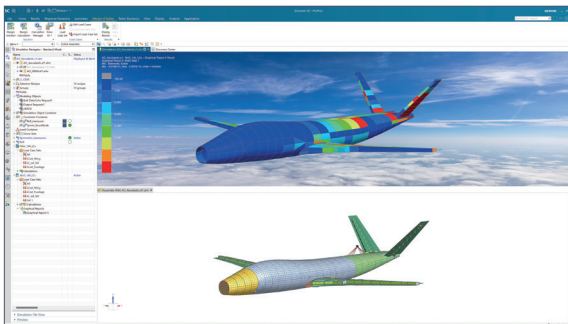
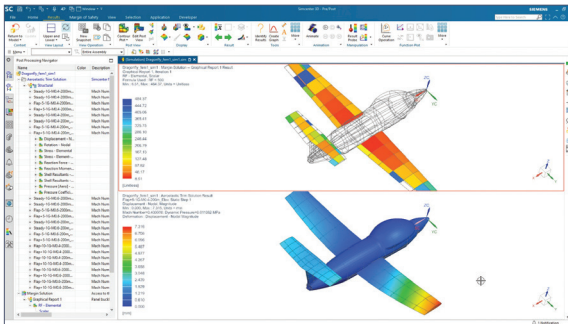

Module benefits

- Speed up overall end-to-end process by up to 30%
- Secure certification schedule
- Reconcile specific know-how and digital thread integration
- Lower learning curve with a fully harmonized environment
- Scales up to real industry complexity (Terabytes of data being processed)

Key features

- Dedicated preprocessing enables you to prepare margin-of-safety calculations for numerous load cases simultaneously, which is available in Simcenter 3D, a powerful finite element pre-/postprocessing open environment
- Dedicated postprocessing focuses on criticality of results (expressed as margins-of-safety or Reserve Factors) either from a global, failure mode or load case point of view
- Results can be browsed to assess structural integrity thanks to sortable and filterable tables
- Each method provides a log for detailed explanations of assumptions
- Dedicated 3D display of margin values combined with the typical FE postprocessing display enables you to graphically locate the areas that need design updates

Simcenter Nastran Advanced Dynamics bundle

Simcenter Nastran Advanced Dynamics is a cost-effective bundle that provides a set of [commonly used and advanced dynamics functionality](#).

Simcenter 3D uses the Simcenter Nastran Advanced Dynamics solver bundle for aeroelasticity simulation. The entire aeroelastic simulation process makes use of Simcenter 3D Engineering Desktop for pre- and postprocessing of the aerodynamic model. The Simcenter Nastran Advanced Dynamics solution is then used for solving the model.

The following Simcenter Nastran aeroelastic solutions are available in this module and are based on the doublet-lattice method:

- Simcenter Nastran SOL145 (Aeroelastic Flutter Analysis)
- Simcenter Nastran SOL144 (Aeroelastic Static Analysis)
- Simcenter Nastran SOL146 (Aeroelastic Dynamic Analysis)

In addition to aeroelastic analysis solutions, the Simcenter Nastran Advanced Dynamics bundle also includes solutions for Simcenter Nastran Dynamic Response, Simcenter Nastran FRF representations, Simcenter Nastran super-element analysis, Simcenter Nastran recursive domain (RD) modes, Simcenter Nastran DMP (distributed memory processing), and Simcenter Nastran direct matrix abstraction program (DMAP).

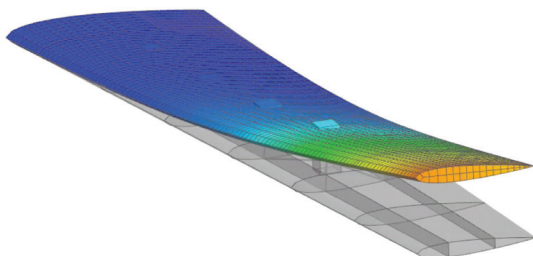

Module benefits for aeroelastic simulation

- Native parametric workflow speeds up trend studies by up to 70%
- Lower overall product development costs by reducing costly, late design change orders
- Decreases the learning curve for a democratized usage of aeroelasticity throughout the engineering community

Key features for aeroelastic simulation

- Works for any subsonic or supersonic speed
- Includes all capabilities of Simcenter Nastran Aeroelasticity, based on doublet-lattice method, including aerodynamic model definition, and connection between structural & aerodynamic models
- Analyze structural models in the presence of an airstream using aeroelastic analysis
- Assess flutter for the whole flight envelope
- Analyze quasi-static trim variables taking into account any control surfaces configuration
- Perform transient or frequential dynamic analysis (e.g. gusts)
- Modify and adapt out-of-the-box (OOTB) solution sequences using DMAP

If you need more features to cope with complex aeroelastic analyses consult the Simcenter ZONA solution guide for an overview of Siemens high-end aeroelasticity simulation capabilities



Capabilities chart

General capabilities	Specific capabilities	Simcenter 3D Engineering Desktop	Simcenter 3D Margin of Safety	Simcenter Nastran Advanced Dynamics bundle
Structural dynamics and aeroelasticity				
Structural and aeroelastic analysis	Aeroelastic Flutter			•
	Aeroelastic Static - Trim			•
	Aeroelastic Static - Divergence			•
	Aeroelastic Dynamic - transient response			•
	Aeroelastic Dynamic - frequency response			•
	Superelements			•
	Direct matrix abstraction programming (DMAP)			•
	Structural linear dynamics			•
Parallel processing	Shared memory parallel (SMP)			•
	Distributed memory parallel (DMP)			•
Aeroelasticity	Lifting surfaces & slender bodies definition	•		
	Load transfer between structural and aerodynamic model definition	•		
	Control surfaces definition	•		
	Aerodynamic model associativity with CAD	•		
	International Standard Atmosphere integration	•		
	Correction factors definition	•		
	Flutter analysis definition using K, KE, PK, or PKNL method	•		
	Static divergence definition	•		
	Trim analysis definition	•		
	Dedicated flutter post-processing (including v-g and v-f diagrams)	•		
	Dedicated trim postprocessing	•		

General capabilities	Specific capabilities	Simcenter 3D Engineering Desktop	Simcenter 3D Margin of Safety	Simcenter Nastran Advanced Dynamics bundle
Margin of Safety				
Workflow and integration	CAD/FE/Stress associativity for geometry update or load update		•	
	Fully integrated Stress analysis		•	
	Data management compatibility	•	•	
	Analytical methods from reference standard methods or end-user methods		•	
	Dedicated post-processing for Margin of safety		•	
	Stress report automated generation		•	
	Metallic static material support (isotropic, orthotropic, anisotropic)	•	•	
	Composite material support (unidirectional long fiber)	•	•	
	Massive geometry data populating through journaling		•	
	Loads	Load extraction from static linear FEM analysis (Simcenter Nastran & MSC. Nastran SOL101 and SOL144)		•
Load extraction via freebody			•	
Load data from the user input			•	
Load data from external load files			•	
Streamline processing of TB of external load results files		•	•	
Group load case (load case set)			•	
Combined load cases		•	•	
Loads case envelop (filtering/ selection of LC by result values)			•	
Strength requirement of Load case (ex: Ultimate/Limit)			•	
Pre-defined load idealization			•	
Configurable load idealization			•	

General capabilities	Specific capabilities	Simcenter 3D Engineering Desktop	Simcenter 3D Margin of Safety	Simcenter Nastran Advanced Dynamics bundle
Margin of Safety (continued)				
Postprocessing and reporting	Postprocessing			
	3D post-processing of critical MS, Load Case , failure mode		•	
	Table of critical MS, Load Case , failure mode		•	
	Detail log of the analysis run		•	
	Reporting			
	Structured templated document	•	•	
	Critical margin of safety table		•	
	3D snapshots (CAD, FE results...)	•	•	
	Material summary	•	•	
	Integrated and user-defined methods	Integrated metallic methods		
Tension/compression/Shear			•	
Tresca (plane stress)			•	
Tsai-Hill			•	
Plate (Flate/curved) buckling analysis under different loads (compressive/shear/bending/ mixed interaction)			•	
Column buckling analysis (Euler/Euler-Johnson, Euler-Engesser)			•	
Torsionnal buckling			•	
Profile Cripling analysis			•	
Inter-rivet buckling			•	
Shear, bending, tension, interaction of a bolt			•	
Bolt/load redistribution			•	
Plasticity (plastic reduction factor charts, StressFromStrainIn Plastic Domain)			•	
Material law (Fsy estimation, Secant/tangent modulus, Stress F07)			•	

General capabilities	Specific capabilities	Simcenter 3D Engineering Desktop	Simcenter 3D Margin of Safety	Simcenter Nastran Advanced Dynamics bundle
Integrated and user-defined methods (continued)	Integrated composite methods (continued)			
	Plate buckling analysis under different loads (compressive/ shear/mixed interaction)		•	
	Documentation			
	End-user documentation		•	
	Methods formulation documentation		•	
	User-defined methods			
	Integration of customer methods : legacy analysis codes or launch of executable		•	
	On the fly mathematical formulation definition		•	
	Automation of high-level process (i.e. automate series of clicks) through journaling	•	•	
	Add user defined material	•	•	
	Add user defined material properties (ex: allowables)	•	•	
	Add user defined profile cross-section	•	•	
	Integration of specific post-processing of MS (including results files in external viewer)		•	
	Method integration documentation management		•	
	Ability to redistribute non-native methods		•	

Legend:

• = included in module

Note: Simcenter 3D Engineering Desktop is a minimum prerequisite for all Simcenter 3D products. Other dependency or prerequisites may apply for individual products.



DIGITAL INDUSTRIES SOFTWARE

Simcenter 3D with simulation process and data management

Organizes complex simulation data with seamless end-to-end data re-usability and traceability

Solution benefits

Deliver results faster by standardizing and automating simulation processes

Support the increasing volume and complexity of simulation work by managing data and processes

Reduce time to find data and enable greater re-use of work

Increase confidence in your simulations with complete traceability from requirements through design and validation

Provide visibility into the simulation process and results for program management and downstream operations

Minimize implementation costs and risk by leveraging the proven Teamcenter platform as your common infrastructure solution

Simcenter™ 3D software with Simulation Process and Data Management (SPDM) allows you to manage simulation models, analysis, results, documents, processes and any relevant metadata across the product life-cycle. This solution combines the power of multiphysics in Simcenter 3D with the convenience of SPDM in Teamcenter. Simcenter is part of the Siemens Xcelerator business platform of software, hardware and services.

In the Teamcenter solution for SPDM, Simcenter 3D files and their relevant metadata are stored in separate containers known as items. Each container or Item can have multiple revisions of data with their own lifecycle.

In addition, connections between these item revisions are connected with well described relationships. These relationships provide useful context on how, where, by whom and when simulation data has been created. This allows for full traceability of simulation work and data in the context of product development.

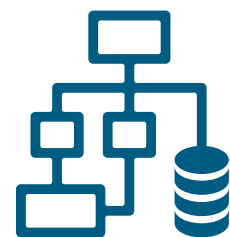

Simulation
Process and Data
Management

SIEMENS

[siemens.com/simcenter3d](https://www.siemens.com/simcenter3d)

Simulation process and data management support

Simulation process and data management is a Teamcenter packaged software solution that enables you to track and manage finite element analysis (FEA) data.

Using this data model and datasets, you can:

- Track item revisions for FEM and simulation files. When you create a new FEM or simulation, specify the number, name and revision
- Create an FEM and simulation on a locked or released CAD part
- Perform where-referenced queries on simulation data in Teamcenter. For example, you can find all simulations defined for a specific master part
- Create computer-aided engineering (CAE) data item revisions and edit their relationships that provides meaningful context for your data
- Create and manage CAE model structures in the Teamcenter client and open those model structures in pre- and postprocessor as assembly FEMs

Providing end-to-end traceability and time savings

Data authored with Simcenter 3D can be seamlessly captured and managed with Teamcenter software for simulation process management. The out-of-the-box CAE data model is used to capture and manage idealized parts, finite element models, simulation files, input decks, results and reports. All Simcenter 3D data is stored in the database with relationship links, thus providing traceability from a product all the way to the associated simulation results. Using the powerful search capabilities,

analysts can quickly find simulation data based on attributes and relationships, thus eliminating rework and overhead in organizing and finding data.

Leveraging structure management and automation

Assembly FEMs authored with Simcenter 3D can be managed in Teamcenter solutions for simulation process management along with complete traceability at the component, sub-assembly and assembly levels. Using automation capabilities, assembly FEMs can be automatically generated from a computer-aided design (CAD) assembly with automatic filtering of parts and re-use of any existing FEMs, which significantly speeds up the model build process.

Effectively managing large amounts of data

Selective download of solution files

A CAE solution dataset may contain multiple results files and other solver-related files in addition to the simulation file. These files can be large, so to improve download times you may prefer not to download them every time the simulation file from Teamcenter is opened.

Providing increased confidence and timely delivery of results

Simcenter 3D provides the ability to generate simulations and results with lightweight the JT™ data format representation. This enables analysts and other parties to visualize product data in Teamcenter without having to launch Simcenter 3D. This provides a framework from which CAE results and related reports can be communicated across the enterprise. Providing clearly traceable outcomes along with process efficiencies facilitates increased confidence and timely delivery of results.

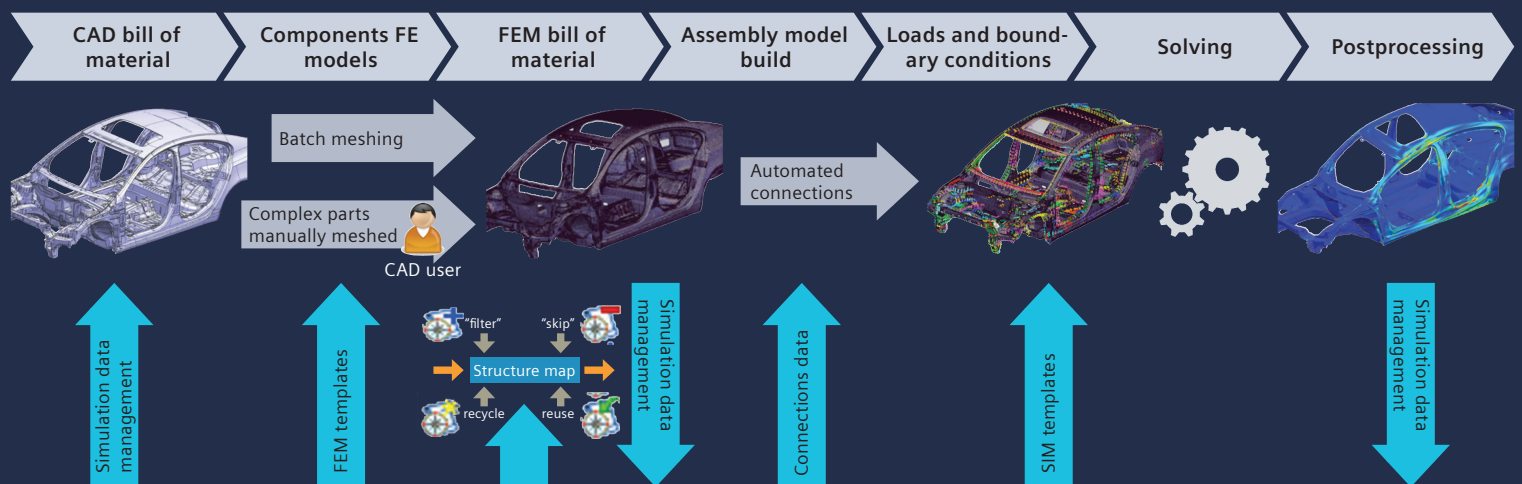

Simulation process and data management
Teamcenter Simulation

Industry applications

Efficiently manage industry-specific CAE simulation processes, data, workflow and share them with all decision-makers to better understand product performance and **deliver highly successful products faster**.

Automotive and transportation

Original equipment manufacturers (OEMs) and supplier engineering organizations need to handle simulation data for an increased number of product variations and configurations to be designed, engineered and manufactured around the globe. As an example, simulation process and data management enables engineering teams to manage the body-in-white (BIW) CAE model build process, automate solves and generate reports. You can also effectively manage knowledge transfer of core product development processes and methods across global sites. Benefits include increased re-use of models, traceability and quality through standardization.

Aerospace and defense

Aerospace companies work in globally distributed environments that necessitate efficient collaboration across teams, OEMs and suppliers. As an example, the aerostructure development process involves managing the integration of global and local models coming from different teams. Additionally, product development data needs to be securely stored for a long time. By capturing technical performance verification and providing continuous access to verified data, the simulation process and data management create a collaborative development environment, including suppliers and partners worldwide. Access to the latest and most accurate information has

been demonstrated to simplify processes, minimize post-design changes and rework and ensure deployment of best practices, which can boost program efficiency.

Marine

The marine industry also works with complex structures and can benefit from using simulation data and process management to ensure fast and secure implementation of product upgrades and modifications.

Industrial machinery and heavy equipment

Companies in agriculture, mining and other heavy equipment manufacturing as well the rotating machinery industry share many of the same needs as companies in the automotive and aerospace industries. As such, simulation data and process management are critical needs in these industries. Predicting performance using advanced multidisciplinary simulation techniques and managing requirements to ensure that all downstream design-manufacturing implications are considered during the early stages of product development requires an open product lifecycle management (PLM) system that is capable of handling CAE data from multiple tools.

Consumer goods

Sporting goods and toy companies want to deliver personalized products and highly customized design by adopting new methods and materials across the value chain. From design through manufacturing, access to the latest simulation data is paramount for fast moving consumer goods companies to develop the right product, on time the first time.

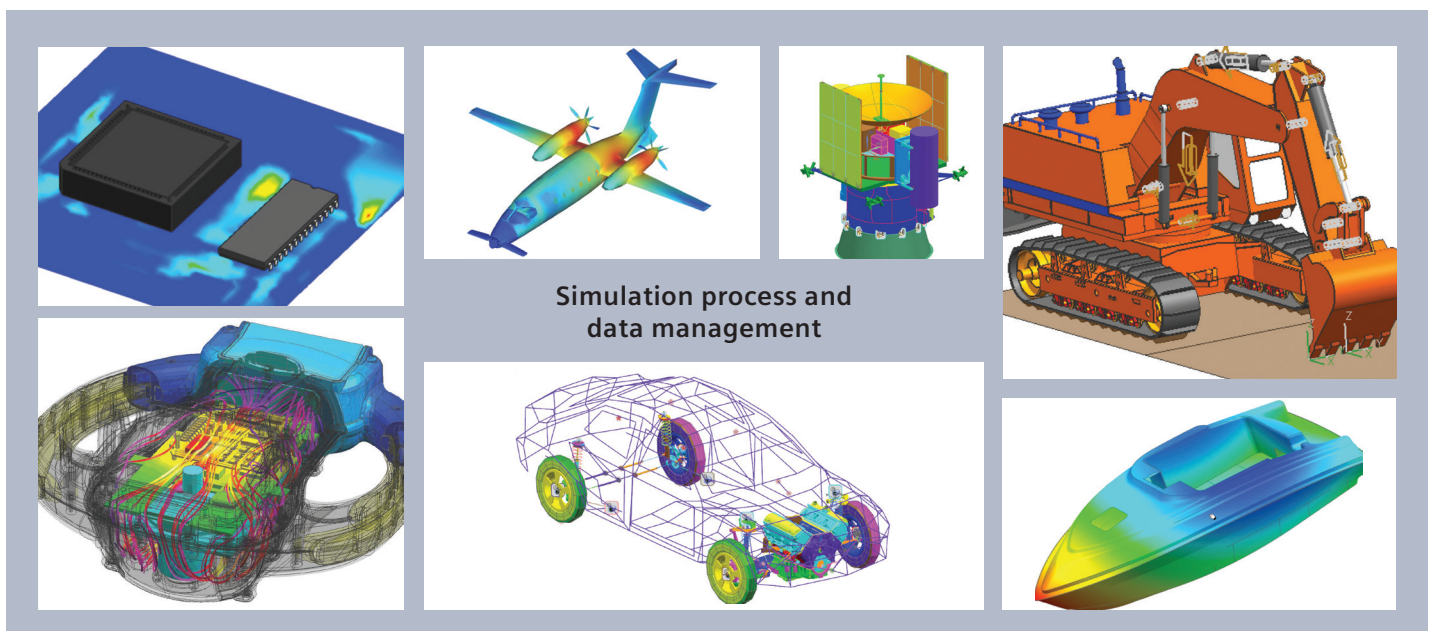

Embedded Client

Embedded Client provides an entry-level management of simulation data and processes. You can capture basic metadata properties as well as Simcenter 3D files into respective containers or Item revisions.

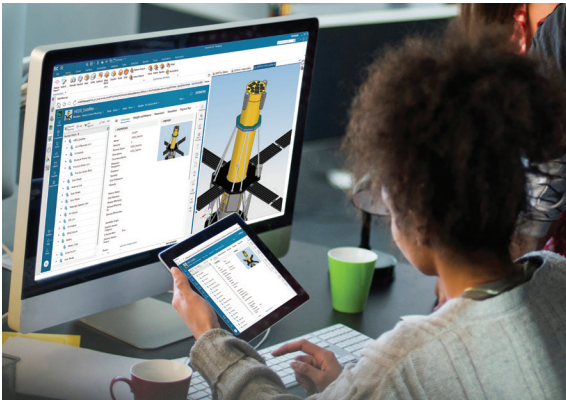

Module benefits

- Manage and accelerate design/simulation collaboration for any size engineering team
- Provides seamless management, control and security for your design and simulation data
- Search rapidly for designs and simulations, manage data revisions, manage product configurations and changes to those product configurations in single or multi-site deployments.
- Access instantly live global product/simulation information
- Manage successfully your most precious asset – product and simulation knowledge

Key features

- Assembly Digital mock-up & multi-CAD
- Teamcenter Navigator:
 - Quick intuitive Teamcenter navigation and searches let you rapidly find the right data to load into the NX/Simcenter 3D session
 - Data for CAM, CAE, routing and mechatronics
- Embedded Active Workspace:
 - Extended access to PLM data: design datasheet, design BOM, where used, MS Office documents, classification, images, requirements
 - Cross-probing to NX navigators and graphics
 - Access to the inbox, submit to workflows

Teamcenter Simulation

Teamcenter Simulation provides an advanced solution to manage simulation processes, data (Simcenter 3D and others), and workflows in context of CAD or design data. This product provides additional capabilities for managing Simcenter 3D data beyond what is included in Embedded Client software (refer to capabilities chart).

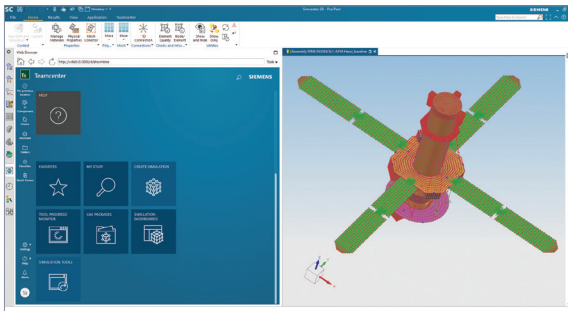

Module benefits

- Removes overhead of organizing and managing simulation data
- Provides end-to-end traceability of simulation data
- Eliminates rework through re-use of existing data
- Improves the efficiency of the model build process through automation and re-use
- Provides a collaborative environment in which simulation tasks can be distributed and executed
- Increases the confidence in the simulation results

Key features

- Simulation data and lifecycle management
- Simulation structure management and automation
- Simulation tool and process management
- Simulation results visualization and reporting
- Verification management covering requirements, system models, detailed designs, and simulation and test activities across the entire program
- Simulation material management with Teamcenter® Integrated Material Management

Capabilities chart

General capabilities	Specific capabilities	Embedded Client	Teamcenter Simulation
Simulation data and lifecycle management	Perform lifecycle operations (create, revise, update, delete etc.) of CAE data from Simcenter 3D GUI	•	•
	Perform lifecycle operations (create, revise, update, delete etc.) of CAE data from Teamcenter GUI		•
	Access to CAE manager application for navigation of CAE data		•
	Access to and management of key performance indicator (KPI) table		•
	Out of date model and out of date analysis detection in Teamcenter		•
	Recipe based creation of multiple CAE objects through CAE packages		•
	Monitor status of models and analysis (attributes, files, and variants) through simulation Dashboards		•
	Assign and manage enterprise-level materials and material libraries	•	•
	Communicate through verification requests across the organization	•	•
Communicate simulation results through program-level parameters	•	•	
Simulation structure management and automation	Manual creation of AFEMs from Simcenter 3D GUI and capture them in the database	•	•
	Manual creation of AFEMs from Teamcenter GUI		•
	Compare AFEM with CAD structure for changes and update (Inspector)		•
	Compare AFEMs (CAE BOM compare)		•
	Automatic generation of AFEMs from CAD structure with reuse of models (through structure maps)		•
Automated model creation through execution of Teamcenter workflows		•	
Simulation tool and process management	Execute meshing and run solver on local machine through Simcenter 3D GUI	•	•
	Perform batch meshing from Teamcenter using Simcenter 3D on local, server or remote (HPC) machines		•
	Perform solver execution from Teamcenter on local, server or remote (HPC) machines		•
Simulation results visualization and reporting	Monitor the progress of jobs (batch meshing or solver)		•
	Access to CAE Manager application for JT visualization of CAE data		•
	Generate CAE JT files from Simcenter 3D GUI	•	•
	Generate CAE JT files from native result files in batch from Teamcenter through an NX Open utility		•

Legend:

- = included in module
- + = additional product required

Siemens Digital Industries Software
siemens.com/software

Americas
 1 800 498 5351

Europe
 00 800 70002222

Asia-Pacific
 001 800 03061910

For additional numbers, click [here](#).

© 2024 Siemens. A list of relevant Siemens trademarks can be found [here](#). Other trademarks belong to their respective owners.

78056-D16 9/24 H

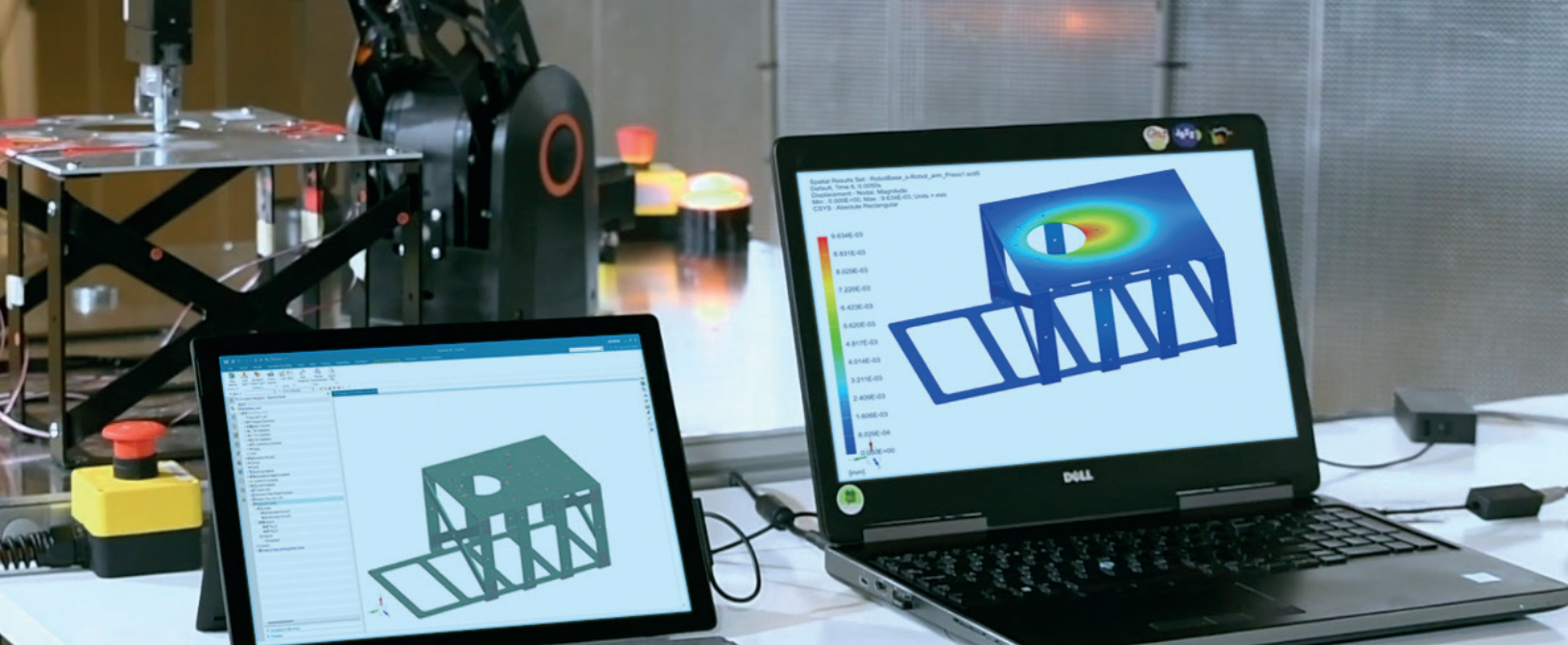

DIGITAL INDUSTRIES SOFTWARE

Simcenter 3D for simulation and test integration

Combining the virtual and physical to improve accuracy, get results in real time and predict performance

Solution benefits

Improve simulation model accuracy by correlating results with physical test data

Gain insight into your inaccessible mechanical components with smart virtual sensors

Optimize your designs structurally or complete lifeing analysis with estimated operational loads in the time domain

Increase test team productivity by determining sensor and exciter locations before performing physical modal tests

Reduce costs by using smart virtual sensors to estimate when maintenance is needed

Leverage knowledge gained from digital twin models throughout the product lifecycle, optimizing investment

Simcenter 3D™ software for simulation and test integration enables you to create a union between test and simulation engineering, creating new possibilities and enabling each function to improve the other. To compare and optimize results, you can correlate your finite element (FE) models to match simulation

results with real-life test data or other FE models. Reduce the burden of setting up physical tests by predicting the optimal location and orientation of sensors or place virtual sensors in locations where it is impossible to position physical sensors to measure the unmeasurable.

These tools remove the silos between design, simulation and test, enabling the test engineer to leverage simulation and reduce the test burden while simulation engineers can work more closely with designers to optimize designs.

SIEMENS

[siemens.com/simcenter3d](https://www.siemens.com/simcenter3d)

Simcenter 3D for simulation and test integration

Increase confidence in your FE models

An integral part of making product engineering decisions is having confidence in the simulation models so you can accurately predict outcomes. Simcenter 3D FE model correlation solutions allow you to validate and improve the dynamic behavior of simulation models so they more closely match results from physical tests.

Optimize sensor placement and improve productivity

Optimize physical tests by minimizing the number of sensors and ensuring they are located at the optimum locations on your specimen to avoid potential dead spots. Physical tests can require hundreds of sensors that are expensive and time-intensive to implement. With Simcenter 3D Smart Virtual Sensing software and its optimal sensor placement tool, you can reduce the number of physical sensors you use and determine locations on the physical structure that will provide the best data.

Measure the unmeasurable

Depending on the geometry of your product or component, there can often be locations on your part where it's impossible to affix a physical sensor. If this happens to be the same location as a hot spot with high strain or stress, it can result in the loss of critical data. With Simcenter 3D, you can create a smart virtual sensor at this location, which enables you to virtually measure the physically unmeasurable locations. Moreover, by generating an executable digital twin (xDT) of your product using the functional mock-up unit (FMU) standard running in real time with your physical test, data from other physical sensors on the model can feed the xDT, which calculates the results for the remote location. This gives you an accurate reading of the hot spot using the virtual sensor.

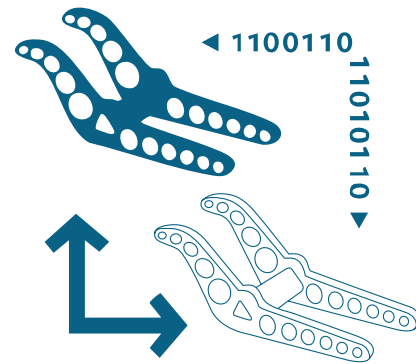

Simulation and test integration

Obtain operational loads

To study structural integrity and durability we need to understand the operational loads to guarantee your products will last for as long as you have planned. Since not all the operational loads can be measured directly, Simcenter 3D Smart Virtual Sensing can help you to obtain the operational loads from simple measurements, for example, from a few strain gauge measurements on the target component. This method transfers the component to a load cell without any modification to the structure. It is easy to deploy with the integrated workflow by combining measurements with an FE model. It can also be used to estimate loads for durability analysis and other analysis in the time domain. The identified operational loads can also be used for durability tests to reproduce the real working conditions and for an efficient validation process.

Industry applications

Physical testing is ubiquitous across all engineering disciplines, but there is no other solution that is more integrated from design through simulation and test than NX™ software, Simcenter 3D and Simcenter Testlab™ software because all three share the same backend. This capability to use test and simulation to optimize design in a feedback loop has advantages in many industries. All three are part of the Siemens Xcelerator business platform of software, hardware and services.

Automotive and transportation

Simcenter 3D is used to execute fatigue-life assessments on body frames, panels, cross-members and door systems as well as sunroofs, latches and locking systems. The Simcenter 3D simulation and test integration solutions enable physical tests to be conducted more quickly by optimizing sensor layout and giving you the ability to measure the strain, stress, acceleration, velocity and displacement at locations that were previously unreachable with indirect sensors.

In addition, the body motion smart virtual sensing provides a smart way to measure the steering wheel position, engine vibration and chassis position in operational conditions.

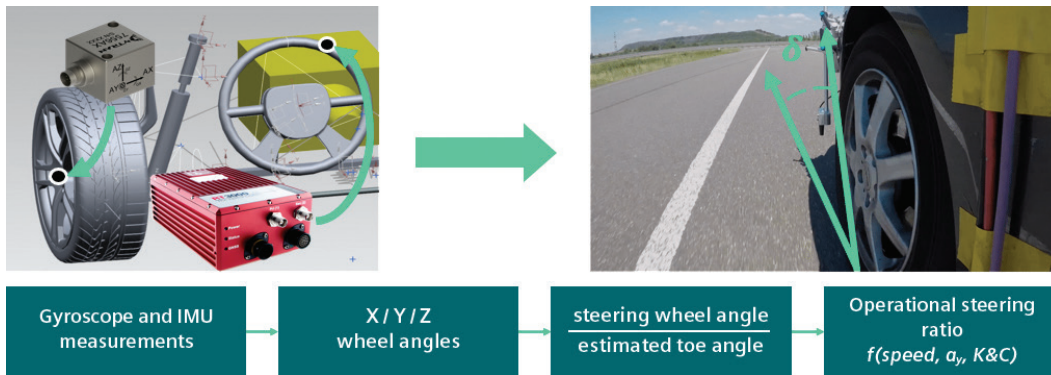
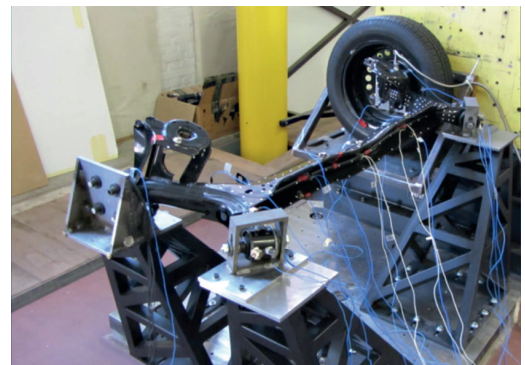
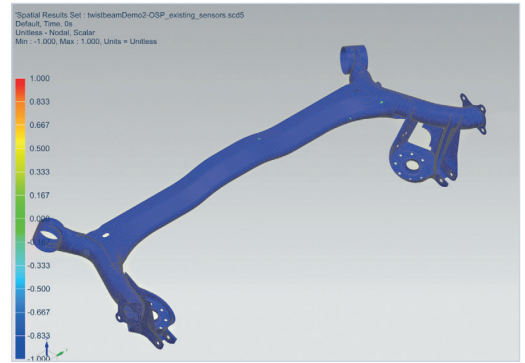

Aerospace and defense

Numerous testing procedures are critical to the success of aerospace projects and with Siemens Digital Industries Software's unique range of tools you can optimize your testing process to improve results and reduce the time it takes to complete your testing processes. You can do this while getting a high-quality FE model that has been correlated by physical tests with our integrated tool chain.

Modal tests and model correlation with updates are widely used in the aerospace industry to ensure the quality of FE models. For example, ground vibration testing (GVT) is used to calibrate and increase the accuracy of the computer-aided engineering (CAE) model of the aircraft structure as part of the industry standard workflow. With the correlated and updated FE model, we can integrate Simcenter 3D Smart Virtual Sensing into the traditional test process to augment the test results with localized details in the places where a physical sensor is not instrumented.

Full-scale static testing verifies modeling assumptions and certifies structures like wings, fuselage, empennage, fuel tanks, integrated systems and engine mounts. Large structures require numerous sensors (more than 1,000), making testing time-consuming and costly. Using Simcenter 3D Smart Virtual Sensing reduces the need for physical sensors, speeding up testing. Deploying smart virtual sensing on a real-time test platform enhances the process by providing real-time stress field visualization during tests and alerting the user to unexpected load cases.

Performing structural health monitoring for the airframe while it is in operation will help improve the reliability of the aerostructure.

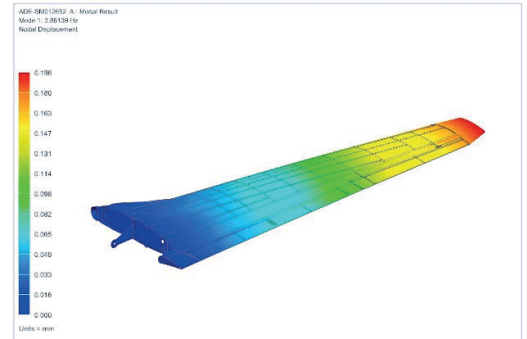

Heavy equipment

Parts that are typically subjected to large dynamic multiaxial load cases can be efficiently optimized. Durability analysis helps the designer gain a deeper insight into the structure and develop better designs. Using Simcenter 3D helps you acquire load scenarios from simple measurements, for example, from a few strain gauge measurements. The operational loads in time series can be further used for durability analysis to find the reason for fatigue with an integrated workflow between Simcenter 3D Smart Virtual Sensing and Simcenter 3D Specialist Durability. The integrated test and simulation solution enable you to deliver smarter, greener and more efficient and reliable heavy equipment.

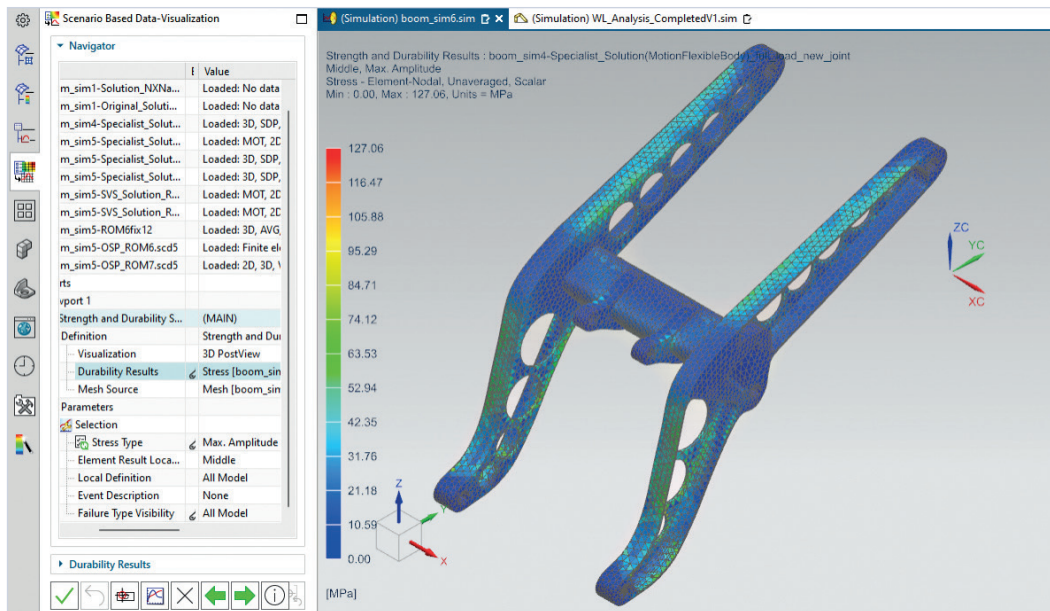

Energy and utilities

The push for a greener world requires lighter, bigger and more complex parts made from new materials. Ensuring an optimized testing program and maintenance planning could be the difference that makes a project viable in this highly competitive market.

Modal testing is performed on wind turbine blades to identify its natural vibrational behavior and ensure the reliability of the wind blade. Model correlation and updating helps to validate the wind blade model, but by combining smart virtual sensing with traditional testing you can cut test cost and speed up the test and validation time. Moreover, smart virtual sensing can help to provide more localized details in the places where there are no physical sensors, which can improve the reliability of the wind blade. This approach can improve any main mechanical component in the energy industry.

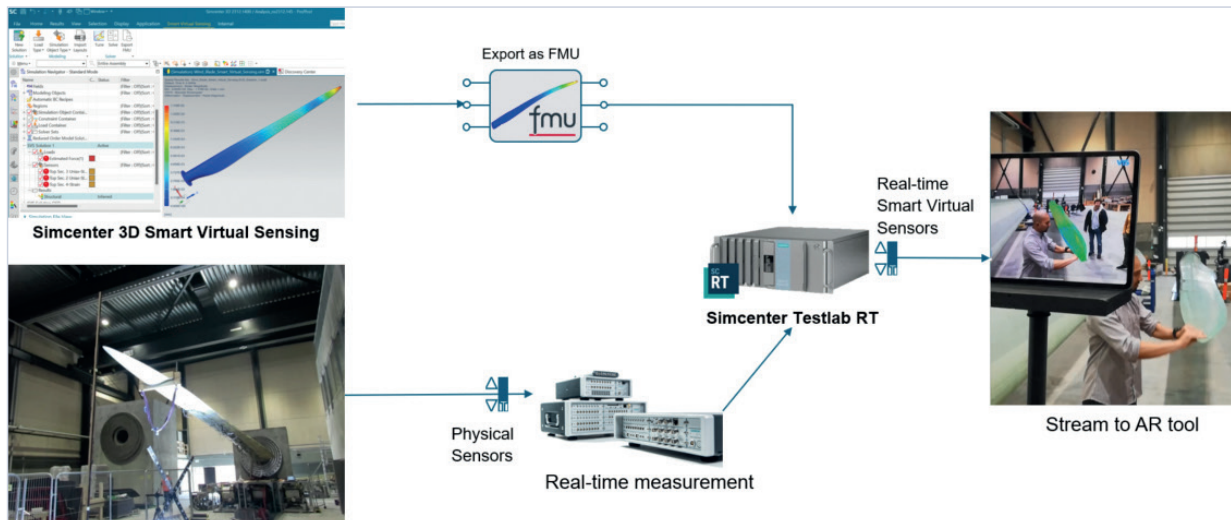

Real-time virtual sensing with Simcenter 3D Smart Virtual Sensing.

Simcenter 3D FE Model Correlation

Using Simcenter 3D FE Model Correlation software enables you to compare simulations quantitatively and qualitatively or simulation and test results. It provides the tools needed to geometrically align the models, pair the shapes from both solutions, view mode and operational shapes and frequency response functions (FRFs) and calculate/display correlation metrics.

Module benefits

- Validate the accuracy of the finite element model (FEM) for structural, acoustic and vibroacoustic dynamic analysis
- Determine sensor and exciter locations before performing physical modal tests
- Increase productivity by enabling model validation in the same environment as used for model creation and analysis

Key features

- Supports Simcenter Nastran software, Abaqus, ANSYS and MSC Nastran results
- Imports test solution using universal files or Simcenter Testlab files
- Pretest planning including sensor and exciter placement, creation of automatic or manual visualization wireframes and automatic face normal detection
- Intuitive and powerful test model alignment
- Shape correlation criteria – MAC, X-Orthogonality, frequency and error
- Modal, operational and static shapes
- Automatic and manual shape pairing
- Interactive matrix and mode-shape displays
- Frequency response function assurance criterion (FRAC)
- Interactive FRAC and FRF overlay plots
- Node mapping based on proximity, labels or names as well as manual methods

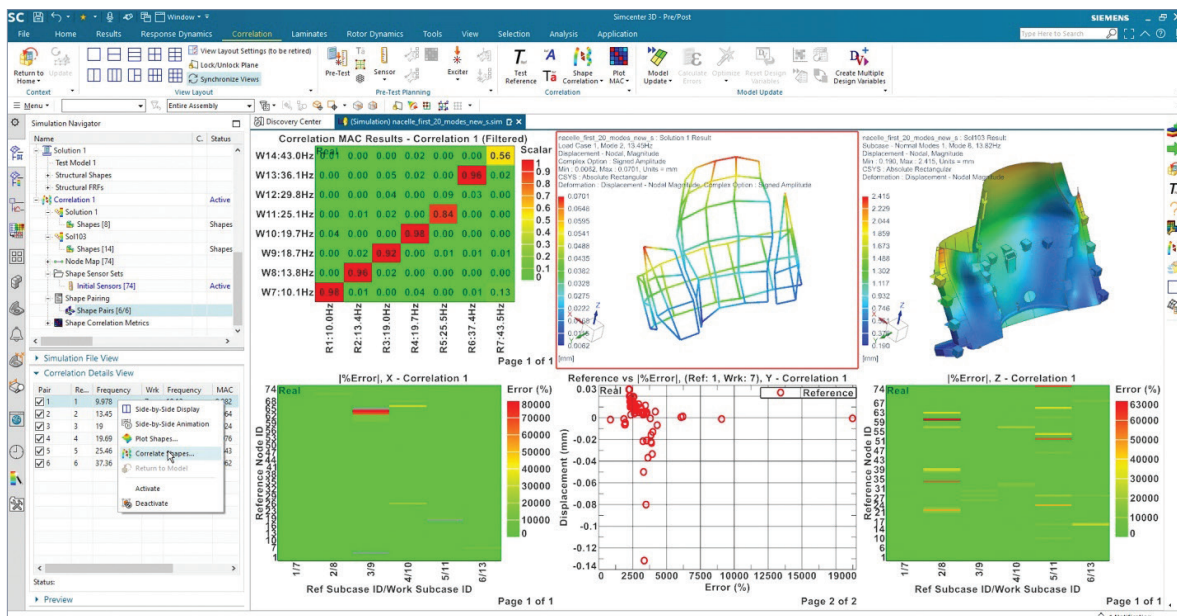

Simcenter 3D FE Model Updating

Simcenter 3D FE Model Updating software is an advanced correlation tool designed to automatically update the digital twin FE models to match real-life test data or other FE model results. The tool is fully integrated in Simcenter 3D Engineering Desktop, making the updating process efficient, intuitive and productive.

Module benefits

- Improve accuracy and increase confidence in your digital twin FE models
- Increase productivity by performing model updating in the same environment used for creating and analyzing models
- Provide a quick, sensitivity-based approach
- Use the HEEDS™ software hybrid and adaptive optimization algorithm. HEEDS is also part of Siemens Xcelerator

Key features

- Optimization targets – modal frequencies, mode shapes and error between response measures

- Mode shape correlation criteria – MAC, X-Ortho
- Automatic and manual mode pairing options with mode clustering
- Simultaneously update multiple configurations of the same FEM
- Automatic FEM update that can be easily cascaded to all simulations
- Simplified automatic and manual design variable management
- Automatic generation of multiple design variables
- Support geometry, material and physical property design variables such as beam section areas, shell or laminate ply thickness and Young’s modulus

Off diagonal and frequency type responses as objective for optimization:

- Simcenter Nastran or MSC Nastran SOL 200 licenses are not required
- HEEDS licenses are not required

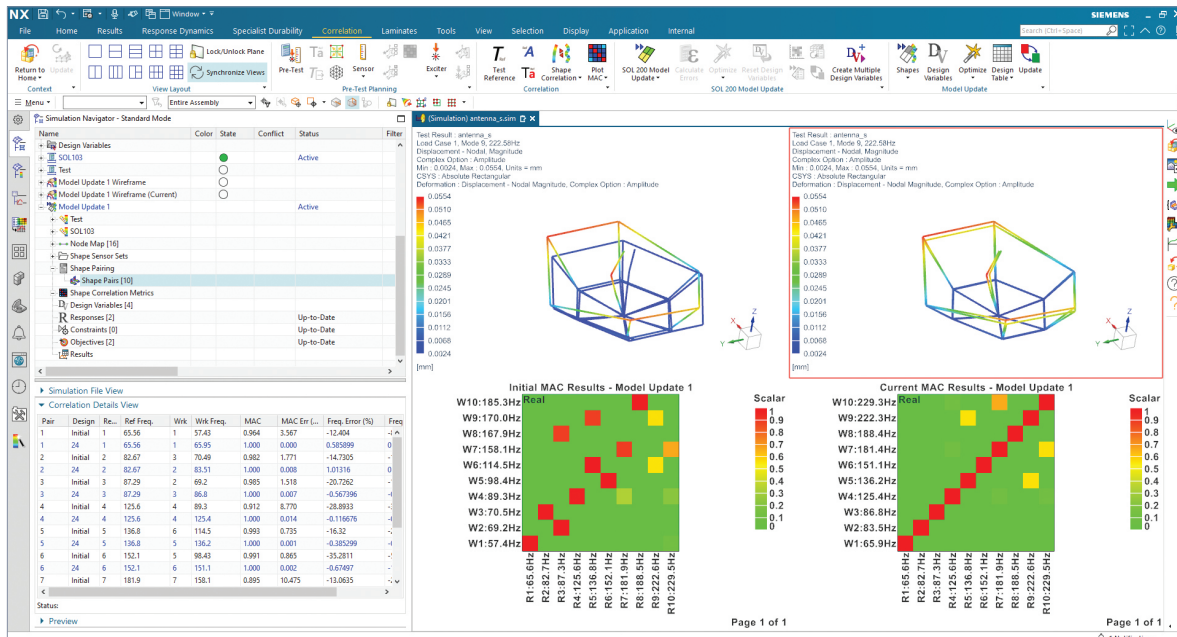

Simcenter 3D

Smart Virtual Sensing

Simcenter 3D Smart Virtual Sensing offers a robust framework to combine limited physical measurements with a structural FE model. This enables you to estimate virtual measurements with great accuracy while compensating for FE model approximations and measurement errors.

Simcenter 3D Smart Virtual Sensing guides the user through a comprehensive workflow, starting from the definition and validation of an optimal/minimal setup of virtual sensors and validation of estimations and visualization of results. It includes the capability to export the smart virtual sensors as smart physics-based xDTs for online or real-time reuse on various platforms.

Simcenter 3D Smart Virtual Sensing plays a pivotal role across the entire product lifecycle. During the

testing and design phases, it is used to augment testing and reduce the cost and time spent on testing, estimate real operational loads and structural strains in otherwise unmeasurable locations. This can also be used to optimize designs; for instance, you can optimize for the remaining life-time by further processing the results in Simcenter 3D Durability. In the manufacturing phase, it facilitates operational monitoring and enhances control strategies. Additionally, in the service phase, smart virtual sensor xDTs enable predictive maintenance.

If you see your design isn't meeting performance requirements, you can rapidly update your design and simulate it again with seamless integration between Simcenter 3D and NX.

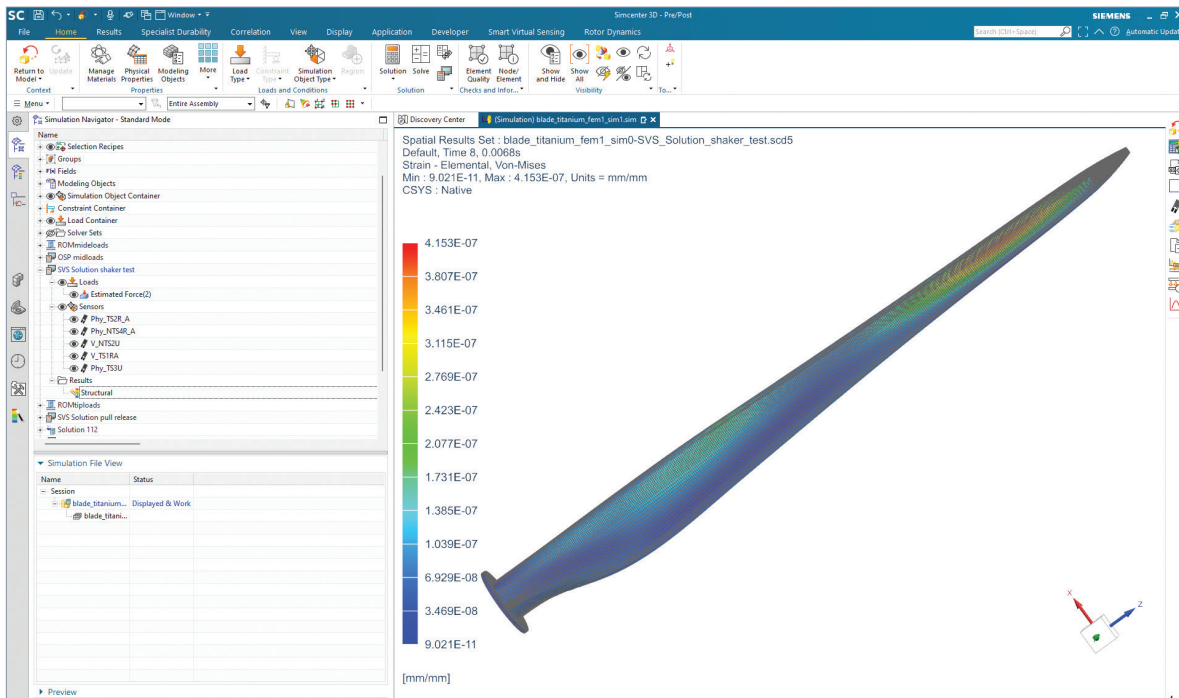

Module benefits

- Gain comprehensive insight into your mechanical component by measuring the unmeasurable (for example, strain at physically unreachable hot spots) and estimating real operational loads in the time domain
- Save on testing cost and time by combining fewer expensive physical sensors with smart virtual sensors
- Use smart virtual sensor measurements and estimated operational loads to optimize the design structurally or for the remaining lifetime by using Simcenter 3D Durability
- Enable smart manufacturing and machine downtime simulation by leveraging physics-based smart virtual sensors for critical control strategies and virtual sensor signal input to programmable logic controllers (PLCs) for closed-loop control
- Reduce maintenance costs by using smart virtual sensors to estimate when maintenance is needed
- Increase productivity with an integrated workflow from design to test
- Leverage knowledge gained from digital twin models in the design phase throughout the product lifecycle, optimizing investment for the entire enterprise

Key features

- Load estimation – Estimate operational loads (force and moment) in the time domain using a minimal set of strain measurements
- Field estimation – Estimate virtual sensors (strain, velocity, acceleration, displacement, damage) at locations that are hard to measure
- Body motion estimation – Estimate body motion with simple measurement, six degrees of freedom (6DOF) sensors or accelerometers
- Data fusion – Harmonize measurement and simulation to achieve a highly accurate estimate with an integrated data fusion method by compensating for both model inaccuracies and measurement errors
- Optimal sensor placement – Ensure efficient data collection while considering instrumentation restrictions
- Real-time estimation – Reduced-order models (ROMs) continually refine estimates in real time, ensuring virtual sensors stay in sync with dynamic reality
- Self-learning – Virtual sensors learn and update the estimation repeatedly at every time step, optimizing the estimation over time
- Platform independence – It works not only with Simcenter 3D for design optimization but can also be exported as an xDT to work on edge devices, real-time platforms and the cloud



Capabilities chart

General capabilities	Specific capabilities	Simcenter 3D FE Model Correlation	Simcenter 3D FE Model Updating	Simcenter 3D Smart Virtual Sensing
Pretest and Correlation	Pretest planning	•		
	Test model alignment and geometry mapping	•		
	Test-analysis, analysis-analysis correlation	•		
	Shape correlation: MAC, COMAC, error scatter, function and matrix	•		
	Modal correlation: X-orthogonality	•		
	Modal, operational, static structural shapes/acoustic mode shapes	•		
	FRF correlation: structural, acoustic and vibro-acoustic	•		
	Local coordinate systems	•		
	Shape pairing and visual comparison	•		
	Simcenter Testlab interface	•		
	Teamcenter interface	•		
		Mode clustering	•	•
Model updating	Design variable definition		•	
	Dedicated DESOPT 200 – model update solution		•	
	Design variable sensitivities		•	
	Frequency, mode shape (MAC and X-orthogonality)		•	
	Embedded eigenvalue solver		•	
	Multiple optimization algorithms		•	
	FEM and SIM update		•	
	Model updating for Simcenter Nastran and MSC Nastran		•	
	Simultaneous update of multiple configurations		•	
Off diagonal and frequency type response as objectives		•		

General capabilities	Specific capabilities	Simcenter 3D FE Model Correlation	Simcenter 3D FE Model Updating	Simcenter 3D Smart Virtual Sensing
Smart Virtual Sensing	Operational load estimation			•
	Virtual sensing/field estimation (stain, stress, velocity, displacement)			•
	Smart Virtual Damage sensor			•
	Optimal sensor placement			•
	Real-time estimation: generates an xDT to be executed out of Simcenter 3D environment such as industrial edge and real time testing platform			•
	Integrated workflow with Simcenter 3D Specialist Durability through dedicated load Event			•
	Rigid body motion estimation (translation, rotation, velocity)			•

Legend:

- = included in module
- + = additional product required

Note: Simcenter 3D Engineering Desktop is a minimum prerequisite for all Simcenter 3D products. Other dependency or prerequisites may apply for individual products.

Appendix

Simcenter 3D Engineering Desktop..... 6

SC12500	Simcenter 3D Engineering Desktop	9
SC12500	Simcenter 3D Environment for Simcenter Nastran..	10
SC30551	Simcenter 3D Environment for Abaqus	11
SC30550	Simcenter 3D Environment for ANSYS	12
SC30523	Simcenter 3D Environment for LS-Dyna	13
SC30549	Simcenter 3D Environment for MSC Nastran	14
SC30552	Simcenter 3D Environment for ADINA	15
SC30522	Simcenter 3D Laminate Composites	16

Simcenter 3D for acoustics simulation ... 58

SC30620	Simcenter 3D Meshing for Acoustics	61
NXN015	Simcenter Nastran Advanced Acoustics	62
NXN017	Simcenter Nastran Acoustics Trim	63
SC30593	Simcenter 3D Acoustic Transfer Vector	64
SC30595	Simcenter 3D Aero-Vibro-Acoustics	65
SC30501	Simcenter 3D Load Identification	66
SC30570	Simcenter 3D Environment for BEM Acoustics.....	67
SC30580	Simcenter 3D Acoustics BEM solver	68
SC30630	Simcenter 3D Acoustics BEMAO solver.....	69
SC30598	Simcenter 3D Acoustics Time Domain BEM solver ..	70
SC30594	Simcenter 3D Acoustics HPC	71
SC30597	Simcenter 3D Ray Acoustics	72
SC30640	Simcenter 3D Acoustics Auralization	73

Simcenter 3D for additive manufacturing simulation128

SC40100	Simcenter 3D Additive Manufacturing	131
NX30188	Pre-deformation in Simcenter 3D	132

Simcenter 3D for aerostructures134

SC30602	Simcenter 3D Margin of Safety.....	137
NXN002	Simcenter Nastran Advanced Dynamics bundle ...	138

Simcenter 3D for electromagnetics simulation102

SC30710	Simcenter 3D Low Frequency Electromagnetics ...	105
SC30711	Simcenter MAGNET Electromagnetic solver	106
SC30712	Simcenter MAGNET thermal solver.....	107

Simcenter 3D for generative engineering 119

NXN007	Simcenter Nastran Optimization	122
NXN016	Simcenter Nastran Topology Optimization.....	123
SC30610	Simcenter 3D Design Space Exploration	124
SC12500	Simcenter 3D Geometry Optimization	125

Simcenter 3D for motion simulation.....77

SC30571	Simcenter 3D Motion Modeling.....	80
SC30572	Simcenter 3D Motion solver.....	81
SC30577	Simcenter 3D Motion Model Export.....	82
SC30581	Simcenter 3D Motion Systems and Controls.....	83
SC30582	Simcenter 3D Motion Flexible Body	84
SC30583	Simcenter 3D Motion Flexible Body Advanced	85
SC30585	Simcenter 3D Motion Standard Tire.....	86
TA50802F	Simcenter Tire	87
SC30590	Simcenter 3D Motion Drivetrain	88

Simcenter 3D for multiphysics simulation 109

Multiple products:

Making multiphysics simulation more effective and reliable 112

Multiple products:

Coupling multiphysics simulation with flow and thermal problems 113

Multiple products:

Coupling multiphysics simulation of mechanical, thermal, and flow problems..... 114

Multiple products:

Coupled multiphysics simulation involving dynamics and acoustics 115

SC30595 Simcenter 3D Aero-Vibro-Acoustics 116

SC30712 Simcenter 3D Electromagnetics/Thermal 117

Simcenter 3D for simulation and test integration 147

SC30527 Simcenter 3D FE Model Correlation 153

SC30528 Simcenter 3D FE Model Updating 154

SC30400 Simcenter 3D Smart Virtual Sensing 155

Simcenter 3D for strength and durability simulation 48

SC30530 Simcenter 3D Durability wizard 51

SC30532 Simcenter 3D Specialist Durability Modeling 52

SC30540 Simcenter 3D Specialist Durability solver 53

SC30541 Simcenter 3D Specialist Durability Composite Fatigue 54

SC30533 Simcenter 3D Specialist Durability for Connections 55

Simcenter 3D for structural dynamics simulation 29

SC30521 Simcenter 3D Response Dynamics 32

SC30596 Simcenter 3D Noise and Vibration Modeling 33

SC30501 Simcenter 3D Load Identification 34

SC30503 Simcenter 3D Noise and Vibration Response 35

SC30500 Simcenter 3D Assembly Composer 36

SC30527 Simcenter 3D FE Model Correlation 37

SC30528 Simcenter 3D FE Model Updating 38

SC30504 Simcenter 3D Rotor Modeling 39

NXN004 Simcenter Nastran Dynamic Response 40

NXN002 Simcenter Nastran Advanced Dynamics bundle 41

NXN010 Simcenter Nastran DMP 42

NXN040 Simcenter Nastran Rotor 43

Simcenter 3D for structural simulation... 20

SC13500 Simcenter 3D Structures 23

NXN001 Simcenter Nastran 24

NXN030 Simcenter Nastran Multistep Nonlinear 25

NXN010 Simcenter Nastran DMP 26

Simcenter 3D for thermal multiphysics simulation 91

SC30780 Simcenter 3D Thermal Multiphysics – Thermal 94

SC30780 Simcenter 3D Thermal Multiphysics – Flow 95

SC30517 Simcenter 3D Space Systems Thermal 96

SC30781 Simcenter 3D Electronic Systems Cooling 97

SC30537 Simcenter 3D Thermal Multiphysics HPC 98

Simcenter 3D with Simulation Process and Data Management..... 141

TC30600 Embedded Client 144

TC31301 Teamcenter Simulation 145

Siemens Digital Industries Software helps organizations of all sizes digitally transform using software, hardware and services from the Siemens Xcelerator business platform. Siemens' software and the comprehensive digital twin enable companies to optimize their design, engineering and manufacturing processes to turn today's ideas into the sustainable products of the future. From chips to entire systems, from product to process, across all industries, [Siemens Digital Industries Software](#) – Accelerating transformation.

Americas: 1 800 498 5351

EMEA: 00 800 70002222

Asia-Pacific: 001 800 03061910

For additional numbers, click [here](#).

© 2025 Siemens. A list of relevant Siemens trademarks can be found [here](#).
Other trademarks belong to their respective owners.
81150-D23 11/25 H